

JVC



COLOUR TELEVISION

HV-34LPZ HV-29LPZ

InteriArt
Premiere

DigiPure

100Hz & PROGRESSIVE SCAN

Contents

Setting up your TV	3
TV buttons and functions	6
Remote control buttons and functions	8
Using the TV's menu	18
Basic operation	18
PICTURE SETTING menu	20
PICTURE FEATURES menu	21
SOUND SETTING menu	24
FEATURES menu	26
INSTALL menu	29
DEMO menu	35
Additional preparation	36
Troubleshooting	40
Specification	43

INSTRUCTIONS

Thank you for buying this JVC colour television.

To make sure you understand how to use your new TV, please read this manual thoroughly before you begin.

WARNING:

TO PREVENT FIRE OR SHOCK HAZARD, DO NOT EXPOSE THIS APPLIANCE TO RAIN OR MOISTURE.

CAUTION:

TO ENSURE PERSONAL SAFETY, OBSERVE THE FOLLOWING RULES REGARDING THE USE OF THIS TV.

- 1 Operate only from the power source indicated on the rear of the TV.
- 2 Avoid damaging the power cord and mains plug. When unplugging the TV, grasp the mains plug. Do not pull on the power cord.
- 3 Never block or cover the ventilation openings.
Never install the TV where good ventilation is unattainable.
When installing this TV, leave spaces for ventilation around the TV of more than the minimum distances as shown.

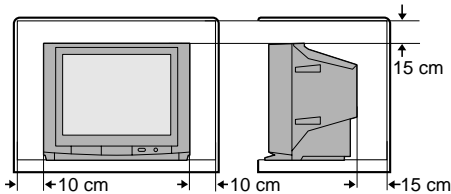

- 4 Do not allow objects or liquid into the cabinet openings.
- 5 In the event of a fault, unplug the unit and call a service technician.
Do not attempt to repair it yourself or remove the rear cover.
- 6 The surface of the TV screen is easily damaged. Be very careful with it when handling the TV. Should the TV screen become soiled, wipe it with a soft dry cloth. Never use rub it forcefully.
Never use any cleaner or detergent on it.
- 7 If you are not going to use this TV for a long period of time, be sure to disconnect the AC plug from the AC socket.

Setting up your TV

CAUTION

- Turn off all the equipment including the TV before connecting anything.

1 Connecting the aerial and VCR

- Aerial cable is not supplied. Use a good quality 75-ohm coaxial cable.
- Read the manual that came with the VCR before connecting.

If not connecting a VCR (see fig.A) :

Connect an aerial cable to the aerial socket on this TV .

If connecting a VCR (see fig.B) :

- 1 Connect the aerial cable to the aerial socket on the VCR, and connect the VCR and TV with another aerial cable.
- 2 Connect the VCR's VIDEO OUT (video output) jack and the TV's VIDEO jack with a video cable.

To connect a VCR to the TV with an S-VIDEO cable:

Connect the VCR's S-VIDEO OUT (S-VIDEO output) connector and TV's S connector with an S-VIDEO cable (A), instead of connecting with a video cable .

- 3 Connect the VCR's VIDEO OUT (audio L/R output) jacks and the TV's AUDIO jacks (L/MONO and R) with an audio cable.

- If the VCR's audio output is in mono, connect the VCR's AUDIO OUT (audio output) jack and the TV's AUDIO L/MONO jack with an audio cable.
- You can use the AV COMPU LINK function if your VCR has an AV COMPU LINK terminal. For details, see "Connecting AV COMPU LINK Supported Devices" on page 38.

Fig.A

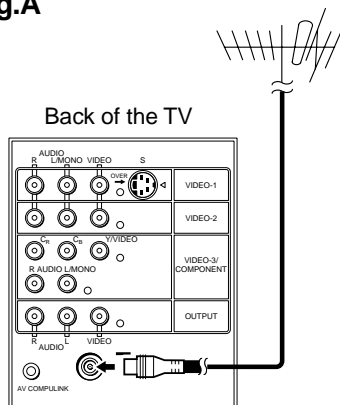
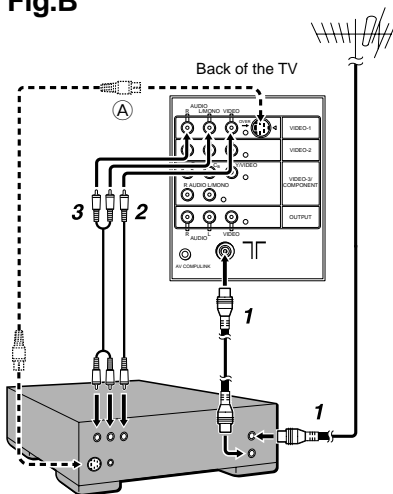

Fig.B



2 Connecting the power cord

Connect the mains plug to the AC outlet.

3 Putting the batteries into the Remote control

Use two AA/R6 batteries.

Insert the batteries from the ⊖ end, making sure the ⊕ and ⊖ polarities are correct.

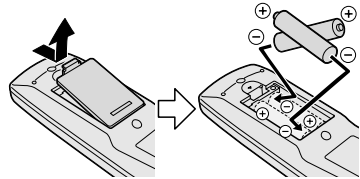

- Follow the warnings printed on the batteries.
- If the remote control does not work properly, replace the batteries.
- The batteries we supply are only for setting up and testing your TV. Please replace them as soon as necessary.

4 Making the initial settings

When the TV is first turned on, it enters the initial setting mode, and the JVC logo is displayed.

1 Press the main power button on the TV

The TV is turned on, and the JVC logo appears.

- If the power lamp on the TV lights red and does not change to green, your TV is in the standby mode. Press the POWER button on the remote control to turn the TV on.
- If the JVC logo does not appear, your TV has already been turned before. In this case, use the "LANGUAGE" and "AUTO PROGRAM" functions to make the initial settings. For details, see "INSTALL menu" on page 29.

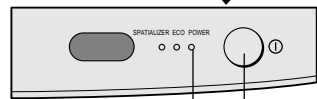
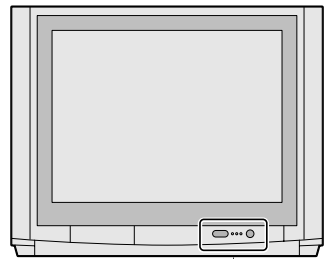

POWER lamp

Main power button

2 Press the MENU/OK button

The LANGUAGE menu appears. You can choose a language for the on-screen language.

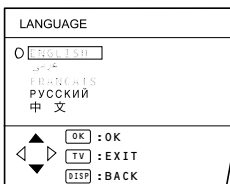

3 Press the ▲/▼ buttons to choose ENGLISH. Then press the MENU/OK button.

The AUTO PROGRAM function starts.
The TV channels you receive are automatically stored in the programme numbers list.

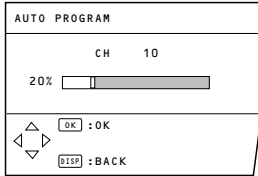

- To cancel the AUTO PROGRAM function, press the DISPLAY button.

4 After the TV channels have been stored in the programme number (PR) list, the EDIT menu appears.

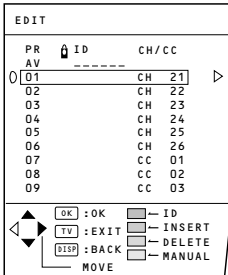

- You can proceed to edit the programme numbers list using the EDIT/MANUAL function. For details, see "EDIT/MANUAL" on page 30.
- If a TV channel you want to view is not stored in the programme numbers list, you can register it using the MANUAL function. For details, see "EDIT/MANUAL" on page 30.
- The AUTO PROGRAM function does not store a TV channel to the programme number 0 (AV).
- If you do not need to use the EDIT/MANUAL function, press the MENU/OK button to close the EDIT menu.

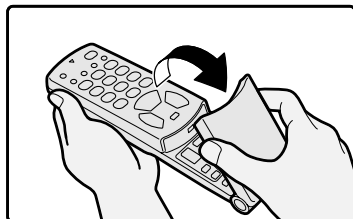
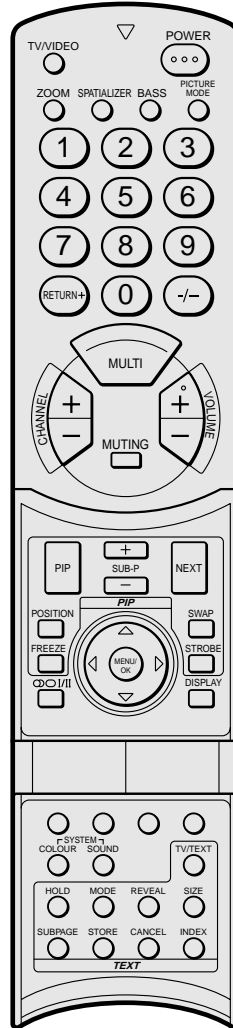

Now, the setting up is complete.
Please enjoy your new JVC TV!

TV buttons and functions

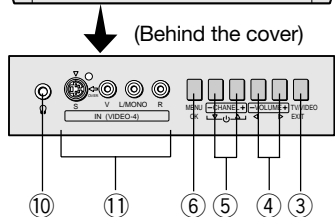
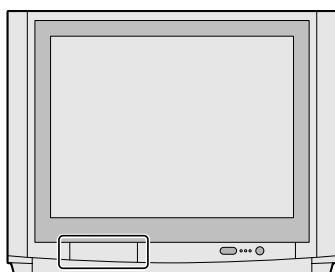
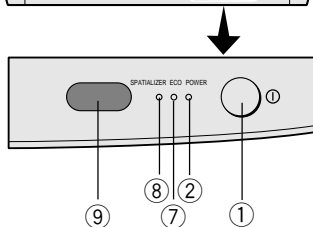
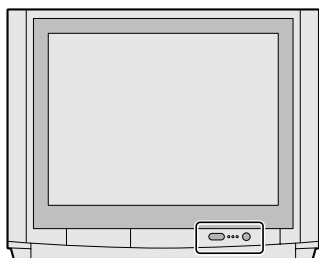

Turn the main power on

Press the main power button ① .

The POWER lamp ② lights red and your TV is in the standby mode.

To turn the main power off :
press the main power button again.
The POWER lamp ② goes off.

Turn the TV on from standby mode

Press the CHANNEL-/+ buttons ⑤ .

The POWER lamp ② lights red to green and your TV will be turned on.

- You can also turn on the TV by pressing the TV/VIDEO button ③ while it is in standby mode.

Choose a TV channel

Press the CHANNEL-/+ buttons ⑤ .

Choose a VIDEO terminal

Press the TV/VIDEO button ③ or CHANNEL-/+ buttons ⑤ .

Adjust the volume

Press the VOLUME-/+ buttons ④ .

The volume level indicator appears.

MENU button ⑥

Press to open the menu.

For details, see "Operation with the buttons on the TV" on page 19.

Remote control sensor and ECO sensor ⑨

ECO lamp ⑦

If you set the DIGITAL ECO SENSOR function to ON or DISPLAY, the ECO lamp lights.

SPATIALIZER lamp ⑧

If you set the SPATIALIZER function to MONO or LIVE, the SPATIALIZER lamp lights.

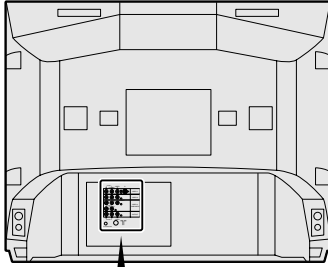

Headphone jack ⑩

Connect the headphones with a stereo mini-jack (3.5mm in diameter). When using the headphones, follow the operation procedure "HEADPHONE" on page 25.

VIDEO-1 terminal ⑫

- See page 3 and 36.

VIDEO-2 terminal ⑬

- See page 36.

VIDEO-3/COMPONENT terminal ⑭

- See page 28 and 36.

VIDEO-4 terminal ⑪

- See page 36.

OUTPUT terminal ⑮

- See page 36.

Aerial socket ⑯

Connect the aerial cable.

- See page 3.

AV COMPU LINK terminal ⑰

- See page 36 and 38.

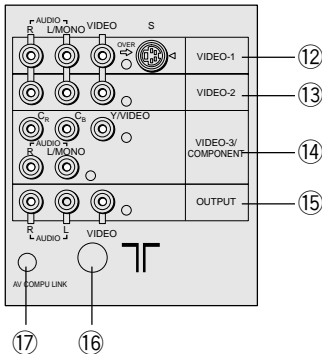

Remote control buttons and functions

Turn the TV on from standby mode

Press the **POWER** button.

The **POWER** lamp lights red to green and your TV will be turned on.

- You can turn on the TV from the standby mode by pressing the **TV/VIDEO** button, the **CHANNEL +/-** buttons or the number buttons.

To turn the TV off:

Press the **POWER** button again.

The **POWER** lamp changes from green to red and the TV enters standby mode.

Choose a TV channel

Choose a programme number in which a TV channel has been set.

Press the **CHANNEL +/-** buttons or enter the programme number (**PR**) with the number buttons.

- If you want to put a two-digit channel into the TV, press the **-/-**-button to change to the two-digit entry system.
- You can select a channel from the **PR LIST**. For details, see "**DISPLAY** button" on page 11.
- If you do not have a clear picture or no colour appears, follow the operation procedure "**COLOUR SYSTEM** button" on page 11.
- If you cannot hear sound normally even when the picture appears normally, follow the operation procedure "**SOUND SYSTEM** button" on page 12.

Adjust the volume

Press the **VOLUME +/-** buttons.

- You cannot adjust the volume of your headphones. Follow the operation procedure "**HEADPHONE**" on page 25.

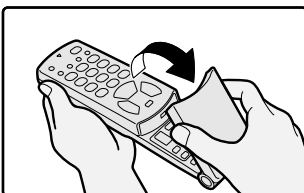
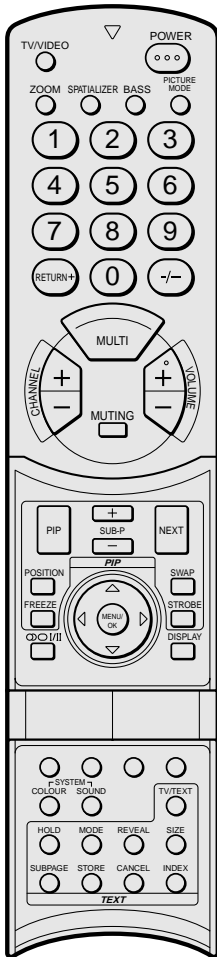

Watch images from external devices

Choose a VIDEO terminal to which the external device has been connected.

Press the TV/VIDEO button.

- You can choose a VIDEO terminal with the CHANNEL +/- buttons or from the PR LIST.

To return to a TV channel:

Press the TV/VIDEO button, the CHANNEL +/- buttons or the number buttons.

MUTING button

Press the MUTING button to turn off the volume. Pressing the MUTING button again resumes the previous volume level.

ZOOM button

You can change the screen size according to the picture aspect ratio. Choose the optimum one from the following ZOOM modes.

Press the ZOOM button to choose a mode.

- If you press the ZOOM button when receiving the Progressive Video Signal (525P signal), "525P" appears on the screen and the ZOOM function does not operate.

REGULAR

Use to view a normal picture (4:3 aspect ratio) as its original size is.

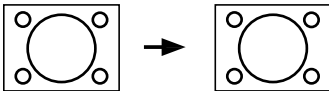

ZOOM

You can zoom up the Wide picture (16:9 aspect ratio) to fill the TV screen.

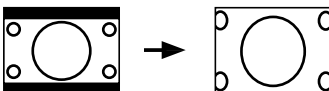

- The left side and right side of the Wide picture (16:9 aspect ratio) will be cut off.

16:9

This mode converts a normal picture (4:3 aspect ratio) into a Wide picture (16:9 aspect ratio).

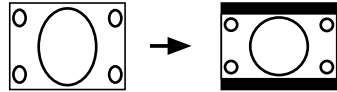

- Use for picture with a 16:9 aspect ratio that have been squeezed into a normal picture (4:3 aspect ratio), you can restore their original dimensions.

SPATIALIZER button

You can enjoy Surround sound with a "live" effect by using the SPATIALIZER function.

Press the SPATIALIZER button to choose a mode.

LIVE :

Live allows you to enjoy normal stereo sound converting it into surround sound with added depth and ambience.

MONO :

Mono allows you to enjoy normal monaural sound by converting it into a stereo-like sound.

OFF :

This function is turned off.

- The LIVE mode works properly only with stereo sound.
- The LIVE mode does not work correctly with headphones.
- The MONO mode works properly only with monaural sound.

The SPATIALIZER is manufactured under license from Desper Products, Inc.

BASS button

You can enjoy a powerful bass sound by using the SUPER BASS(Super Bass Reflex) function.

Press the BASS button to turn the SUPER BASS function on or off.

ON :

This function is turned on.

OFF :

This function is turned off.

PICTURE MODE button

You can choose one of three PICTURE MODEs (three kinds of picture setting) to adjust the picture settings automatically.

Press the PICTURE MODE button choose a mode.

BRIGHT :

Heightens contrast and sharpness.

STANDARD :

Standardizes picture adjustment.

SOFT :

Softens contrast and sharpness.

RETURN+ button

The RETURN+ button has two functions; the RETURN+ function and the RETURN function. If a channel has been registered as the "Return Channel", the RETURN+ function operates. If there is no setting for the "Return Channel", the RETURN function operates.

RETURN+ function :

By registering a channel you frequently view as the "Return Channel", you can select that channel at any time simply by pressing the RETURN+ button.

To register a TV channel as the "Return Channel" :

Choose the Programme number to which the channel you want to register has been set, and press the RETURN+ button and hold for more than 3 seconds continuously. "RETURN PLUS PROGRAMMED!" is displayed and the registration is completed.

To cancel register a TV channel as the "Return Channel" :

while viewing any TV channel, press the RETURN+ button and hold for more than 3 seconds continuously. "RETURN PLUS CANCELED!" is displayed and the registration is cancelled.

- When you turn off the TV, the registration for the "Return Channel" is cancelled.
- If you want to view the "Return Channel" and another TV channel alternately, first choose a channel other than the "Return Channel". and then press the RETURN+ button to change the channel to the "Return Channel" In this way, you can view two channels alternately by pressing the RETURN+ button.

RETURN function :

The TV temporarily memorises the TV channel that was chosen right before the current TV channel as the "Last Channel". By pressing the RETURN+ button, you can alternately view the current TV channel and the "Last Channel".

- If you want to view two channels alternately by using the RETURN function, first choose one TV channel and then choose the other TV channel with the Number buttons. If you choose the TV channel without using the Number buttons, there are cases where a channel other than the one you first chose is registered as the "Last Channel".

∞ ○ I/II button

When you are viewing a bilingual broadcast programme, you can choose the sound from Bilingual I (Sub I) or Bilingual II (Sub II). When the stereo broadcasting is received poorly, you can change from stereo to mono sound so that you can hear the broadcast more clearly and easily.

Press the ∞ ○ I/II button to choose a sound mode.

- ∞ : Stereo sound
- : mono sound
- I : Bilingual I (sub I)
- II : Bilingual II (sub II)

MONO : Cancels the Multi Sound function, and the sound becomes monaural.

- The sound mode you can choose differs depending on the TV programme.
- This function does not work in the VIDEO modes.

DISPLAY button

You can display the PR LIST, programme number or VIDEO terminal number on the screen.

Press the DISPLAY button.

Press the DISPLAY button changes the display as follows:

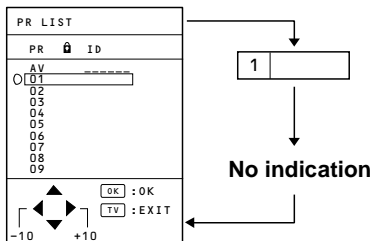

Choose a TV channel or a VIDEO terminal

- 1 Press the DISPLAY button to display the PR LIST.
- 2 Press the ▲/▼ and ◀/▶ buttons to choose a programme number or VIDEO terminal. Then press the MENU/OK button.

- For programme numbers with the CHANNEL GUARD function set, the (CHANNEL GUARD) mark is displayed next to the programme number in the PR LIST.
- The VIDEO terminals are registered after the programme number PR99.

COLOUR SYSTEM button

The colour system is chosen automatically. However, if the picture is not clear or no colour appears, choose the colour system manually.

Press the COLOUR SYSTEM button to choose the appropriate colour system.

AUTO :

This function detects a colour system from the input signal.

- The AUTO mode may not function properly if you have poor signal quality. If the picture is abnormal in the AUTO mode, choose another colour system manually.
- The AUTO mode detects a colour system from the input signal and chooses the appropriate colour system automatically.
- When changing the COLOUR SYSTEM of the SUB-picture, see "Change the colour system of the SUB-picture" on page 15 for details.

Remote control buttons and functions

- For the colour systems in each country or region, see the table "BROADCASTING SYSTEMS" on page 12.

SOUND SYSTEM button

The sound system is chosen automatically. However, if you cannot hear the sound normally even when the picture appears normally, choose the sound system manually.

Press the SOUND SYSTEM button to choose the appropriate sound system.

B/G : B/G system

I : I system

D/K : D/K system

M : M system

- This function does not work in the VIDEO mode.
- For the sound systems in each country or region, see the table "BROADCASTING SYSTEMS" on page 12.

BROADCASTING SYSTEMS

For sound system colour system in your country or region, refer to the table below.

COLOUR SYSTEM

Area	Country or Region	System
Asia, Middle East	Bahrain, Kuwait, Oman, Qatar, United Arab Emirates, Yemen, etc. Indonesia, Malaysia, Singapore, Thailand, India, etc.	PAL
	China, Vietnam, etc	PAL
	Hong Kong, etc	PAL
	Islamic Republic of Iran, Lebanon, Saudi Arabia, etc.	SECAM
	Philippines, Taiwan, Myanmar, etc	NTSC
Europe	Russia, etc	SECAM
	Czech Republic, Poland, etc	PAL
	Germany, Holland, Belgium, etc	PAL
	UK, etc	PAL
Oceania	Australia, New Zealand, etc	PAL
Africa	Republic of South Africa, etc	PAL
	Nigeria, etc	PAL
	Egypt, Morocco, etc	SECAM

SOUND SYSTEM

Area	Country or Region	System
Asia, Middle East	Bahrain, Kuwait, Oman, Qatar, United Arab Emirates, Yemen, etc. Indonesia, Malaysia, Singapore, Thailand, India, etc.	B/G
	China, Vietnam, etc	D/K
	Hong Kong, etc	I
	Islamic Republic of Iran, Lebanon, Saudi Arabia, etc.	B/G
	Philippines, Taiwan, Myanmar, etc	M
Europe	Russia, etc	D/K
	Czech Republic, Poland, etc	D/K
	Germany, Holland, Belgium, etc	B/G
	UK, etc	I
Oceania	Australia, New Zealand, etc	B/G
Africa	Republic of South Africa, etc	I
	Nigeria, etc	B/G
	Egypt, Morocco, etc	B/G

FREEZE button

You can view the Main picture's frozen image as the SUB-picture.

Press the FREEZE button.

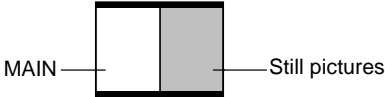

To cancel the FREEZE function :

Press the FREEZE button again.

- You cannot use the FREEZE button when the SUB-picture or the MAIN-picture are displayed on the screen.
- If you press the FREEZE button when receiving the Progressive Video Signal (525P signal), "525P" appears on the screen and the FREEZE function does not operate.

STROBE button

You can view the MAIN-picture as 15 consecutive still images.

Press the STROBE button.

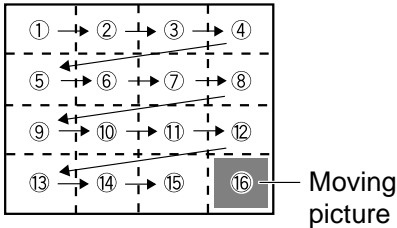

To cancel the STROBE function:

Press the STROBE button to return to the MAIN-picture.

- If signal level of the MAIN-picture is weak, the still images become abnormal.
- You cannot use the STROBE button when the SUB-picture or the MAIN-picture are displayed on the screen.

- If you press the STROBE button when receiving the Progressive Video Signal (525P signal), "525P" appears on the screen and the STROBE function does not operate.

- You cannot change the TINT setting for the still images on the screen even if you are viewing a programme with NTSC colour system.

■ Using the MULTI function

You can display multi-pictures that enable you to easily find a program you want to view.

1 Press the MULTI button.

Press the MULTI button changes the display as follow:

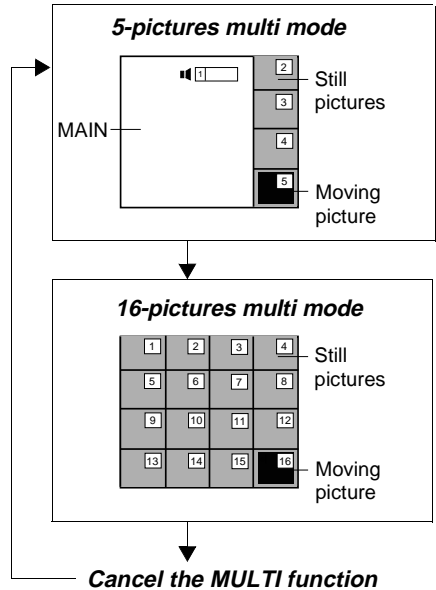

To display next Multi pictures :

Press the NEXT button.

2 Choose the desired picture with the ▲/▼ and ◀/▶ buttons, and then press the MENU/OK button.

The screen switches to the TV channel or VIDEO mode of your choice.

- Any programme numbers to which no TV channel has been registered, or programme numbers to which CHANNEL GUARD has been set is not displayed.
- You cannot perform menu operations such as headphone volume adjustment. Cancel the MULTI function once to perform menu operations.
- If you press the MULTI button when receiving the Progressive Video Signal (525P signal), "525P" appears on the screen and the MULTI function does not operate.
- During the short period that is required for the Multi-pictures display to close no sound comes from the television.

■ Using the PIP function

You can view two pictures (MAIN and SUB) at the same time.

Press the PIP button.

Press the PIP button changes the display as follows:

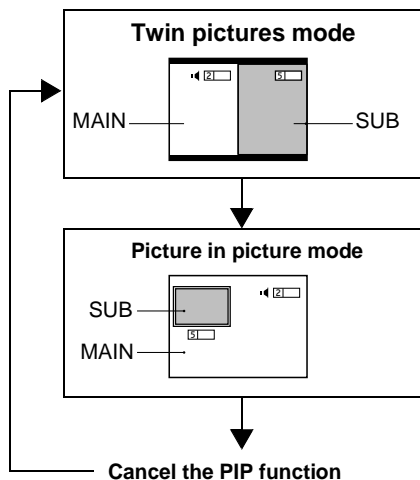

- You cannot view a picture from the same programme number (or the same VIDEO terminal) as both the MAIN-picture and the SUB-picture at the same time.
- If the MAIN-picture signal is poor, then the quality of the SUB-picture may also be poor.
- If the picture standards of both pictures are different, the top and bottom or one of them may be missing.
- The ZOOM function does not operate when viewing pictures using the PIP function.
- The SUB-picture cannot be output from TV.
- If you press the PIP button when receiving the Progressive Video Signal (525P signal), "525P" appears on the screen and the PIP function does not operate.

Choose a TV channel for the SUB-picture

Press the SUB-P +/- button.

Listen to the sound of SUB-picture

You can listen to the sound of SUB-picture on your headphones while listening to the sound of MAIN-picture on the TV speakers. For details, see "HEADPHONE" on page 25.

Change the colour system of the SUB-picture

- 1 While the SUB-picture is displayed, press the MENU/OK button to display the MENU (main manu).
- 2 Press the ▲/▼ and ◀/▶ buttons to choose PICTURE FEATURES, and then press the MENU/OK button.
- 3 Press the ▲/▼ buttons to choose COLOUR SYSTEM, and then press the MENU/OK button.

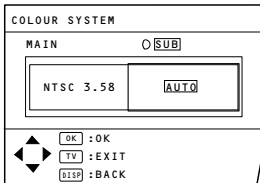

- 4 Press the ◀/▶ buttons to choose SUB, and then press the ▲/▼ buttons to choose the appropriate colour system. Then press the MENU/OK button.

- You cannot change the COLOUR SYSTEM of the SUB-picture using the COLOUR SYSTEM button on the remote control.

POSITION button

You can adjust the position of the SUB-Picture when using the Picture in picture mode.

Press the POSITION button repeatedly.

Each time you press the button, the SUB-Picture moves counterclockwise.

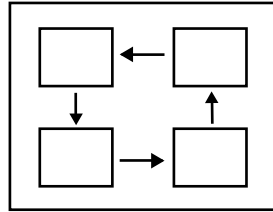

SWAP button

You can replace the MAIN-picture and the SUB-picture with each other.

Press the SWAP button.

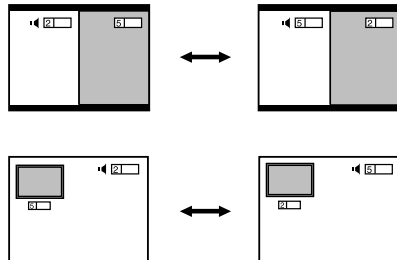

- Do not press the SWAP button while you are recording the TV output on the VCR. If you do, the output signal will change.

■ Viewing a teletext programme

- 1 Choose a TV channel with a teletext broadcast.
- 2 Press the TV/TEXT button.

Pressing the TV/TEXT button changes the mode as follows:

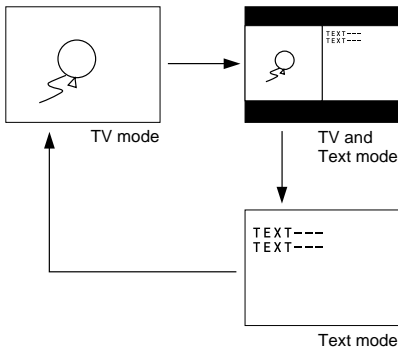

- 3 Choose a teletext page by pressing the CHANNEL-/+ buttons, number buttons or coloured buttons.

To return to the TV mode:

Press the TV/TEXT button or TV/VIDEO button.

- If you have trouble receiving teletext broadcasts, consult your local dealer or the broadcast station.
- In the Text mode, the ZOOM mode is fixed to the REGULAR mode.
- No menu operations are possible when viewing a teletext programme.
- If characters on a teletext programme do not appear properly, change the TELETEXT LANGUAGE setting. For details, see "TELETEXT LANGUAGE" on page 34.

HOLD button

You can hold a teletext page on the screen for as long as you want, even while several other teletext pages are being received.

Press the HOLD button.

The  (hold) are displayed at the top left of the screen.

To cancel the Hold function:

Press the HOLD button again.

REVEAL button

Some teletext pages include hidden text (such as answers to a quiz).

You can display the hidden text.

Each time you press the REVEAL button, text is hidden or revealed.

SIZE button

You can double the height of teletext display.

Press the SIZE button.

INDEX button

You can return to the index page instantly.

Press the INDEX button.

- In the List mode, you can return to the page number displayed in the lower left area of the screen.

CANCEL button

You can search for a teletext page while watching TV.

- 1 Press the number button to enter a page number, or press the coloured button.

The TV searches for a teletext page.

2 Press the CANCEL button.

The TV programme appears. When the TV finds the teletext page, its page number appears in the upper left of the screen.

3 Press the CANCEL button to return to a teletext page when the page number is on the screen.

- You cannot return to the TV mode with the CANCEL button.

SUBPAGE button

Some teletext pages include sub-pages that are automatically displayed. You can hold any sub-page, or view it at any time.

1 Press the SUBPAGE button to operate the Sub-page function.

Sub-page numbers are displayed at the left of the screen.

Colour*	Meaning of sub-page number
Yellow	Currently being displayed.
White	Can be displayed.
Blue or Red	Cannot be displayed and it is not sent.

* : Background color of the sub-page number.

2 Press the CHANNEL +/- buttons to choose a sub-page number.

To cancel the Sub-page function:
Press the SUBPAGE button again.

Using the List mode

You can store the numbers of your favourite teletext pages in memory and call them up quickly using the coloured buttons.

To store the page numbers :

1 Press the MODE button to engage the List mode.

The stored page numbers are displayed at the bottom of the screen.

2 Press a coloured button to choose a position. Then press the number buttons to enter the page number.

3 Press and hold down the STORE button.

The four page numbers blink white to indicate that they are stored in memory.

To call up a stored page :

1 Press the MODE button to engage the List mode.

2 Press a coloured button to which a page has been assigned.

To exit the List mode :

Press the MODE button again.

Using the TV's menu

This TV has a number of functions you can operate using menus. To fully utilize all your TV's functions, you need to understand the basic menu operating techniques fully.

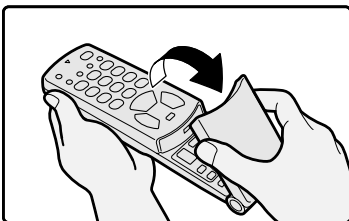
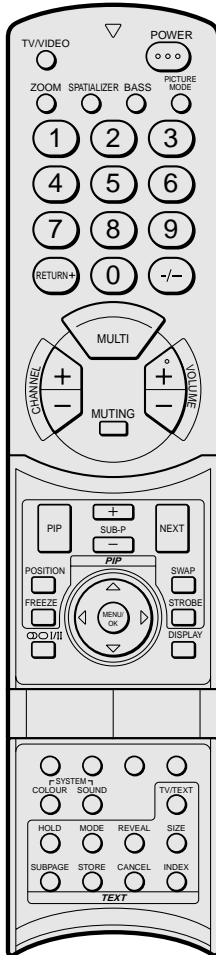

Basic operation

- 1 Press the MENU/OK button to display the MENU (main menu).

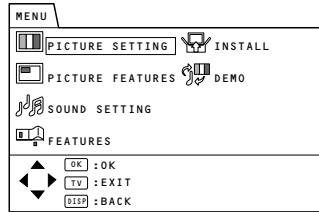

- The display appearing at the bottom of a menu indicates buttons on the remote control you can use when you operate a chosen function.

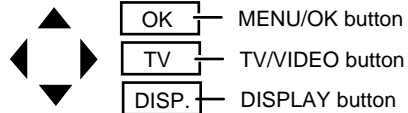

- 2 Press the ▲/▼ and ◀/▶ buttons to choose a menu title, and press the MENU/OK button.

The menu appears.

To return to the previous menu:
Press the DISPLAY button.

To exit a menu instantly:
Press the TV/VIDEO button.

- 3 Press the ▲/▼ buttons to choose a function.

- For details of the functions in the menus, see the following pages.

4 Press the ◀/▶ buttons to choose the setting of that function.

- If you want to operate a function which appears only with its name, follow the descriptions of that function on the following pages.

5 Press the MENU/OK button to complete the setting.

The menu disappears.

- When watching the television with the NTSC system, the menus are displayed at about half of their normal vertical size.

Operation with the buttons on the TV

You can also operate the menus using the buttons on the front panel of the TV.

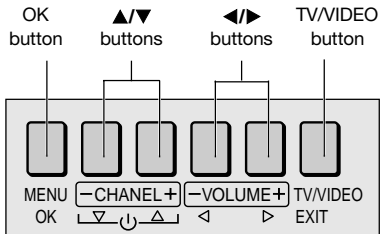

- There is no button on the front panel of the TV that has the function of the DISPLAY or coloured buttons.

PICTURE SETTING menu

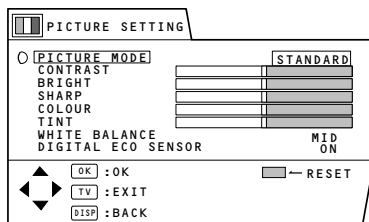

PICTURE MODE

You can choose one of three PICTURE MODEs to adjust the picture settings automatically.

BRIGHT:

Heightens contrast and sharpness.

STANDARD:

Standardizes picture adjustment.

SOFT:

Softens contrast and sharpness.

- You can also operate the PICTURE MODE function with the PICTURE MODE button on the remote control. For details, see "PICTURE MODE button" on page 10.

Adjusting the picture

You can change the picture settings of each picture mode as you like. The picture settings changed are stored in the picture mode.

CONTRAST

You can adjust the picture contrast.

- ◀: lower
- ▶: higher

BRIGHT

You can adjust the picture brightness.

- ◀: darker
- ▶: brighter

SHARP

You can adjust the picture sharpness.

- ◀: softer
- ▶: sharper
- You cannot select the SHARP function when receiving the Progressive Video Signal (525P signal).

COLOUR

You can adjust the picture colour.

- ◀: lighter
- ▶: deeper

TINT

You can adjust the picture tint.

- ◀: reddish
- ▶: greenish
- You can change the TINT setting (picture tint) only when the colour system is NTSC 3.58 or NTSC 4.43.
- You cannot select the TINT function when receiving the Progressive Video Signal (525P signal).

To return to the default settings in each PICTURE MODE :

Press the blue button. Returns the picture settings in the currently chosen PICTURE MODE mode to the default settings, and stores them in the PICTURE MODE again.

WHITE BALANCE

You can select one of three WHITE BALANCE modes (three tones of white) to adjust the white balance of the picture. Since white is the colour which is used as a reference for all the other colours, changing the WHITE BALANCE mode affects the appearance of all the other colours on the screen.

COOL:

A bluish white. Using this mode when watching bright pictures allows you to enjoy a more vivid and bright picture.

MID:

The normal white colour.

WARM:

A raddish white. Using this mode when watching films allows you to enjoy colours that are characteristic of films.

- You cannot select the WHITE BALANCE function in the Twin pictures mode or the 16:9 mode of the ZOOM function.

■ DIGITAL ECO SENSOR

When you set the DIGITAL ECO SENSOR function to ON, the screen contrast is automatically adjusted to a setting suitable for the brightness of your room. This reduces eye strain for you and the power consumption of the TV.

ON :

This function is turned on.

OFF :

This function is turned off.

DISPLAY :

This function is turned on. Further, clover marks ♣ indicating the brightness of your room are displayed for several seconds each time the brightness changes. The number of clover marks displayed on the screen increases as your room becomes darker.

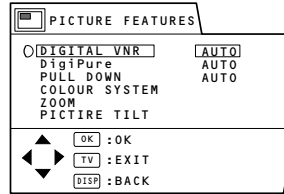
PICTURE FEATURES menu**■ DIGITAL VNR**

The DIGITAL VNR function cuts down the amount of noise in the original picture.

- You cannot select the DIGITAL VNR function when receiving the Progressive Video Signal (525P signal).

AUTO:

The TV will be automatically adjust the level of the DIGITAL VNR effect to match the amount of noise in the picture, giving you the best possible picture.

- If you set the DIGITAL VNR effect too high it can make the picture less sharp. It is recommended to use the AUTO setting if you can.

MAX:

The level of the DIGITAL VNR effect is set to the maximum. If you set the DIGITAL VNR function to AUTO but still notice some noise, change the setting from AUTO to MAX.

- The MAX setting is not suitable for high-quality pictures which contain a lot of noise.

MIN:

The level of the DIGITAL VNR effect is set to the minimum. If you set the DIGITAL VNR function to AUTO but feel that the sharpness of the original picture has not been reproduced fully, change the setting from AUTO to MIN.

- The MIN setting is not suitable for low-quality pictures which contain a lot of noise.

■ DigiPure

The DigiPure function uses the latest in digital technology to give you a natural looking picture. The DigiPure function includes the following two functions.

DigiPure function:

This function helps to create a natural looking picture by eliminating unnecessary edges from high-contrast and crisp images.

Conversely, for images with low-contrast, edges are added to produce a sharper, more detailed picture.

You can choose from the DigiPure function settings of AUTO, MIN and MAX.

Picture motion compensation function:

This function displays fast-moving pictures (for example, the players or ball in a football game) more smoothly and naturally on the screen.

- You cannot select the DigiPure function when receiving the Progressive Video Signal (525P signal).

AUTO:

The TV will automatically adjust the level of the DigiPure effect to match the amount of noise in the picture, giving the best possible picture.

- If you set the DigiPure effect too high on a low-quality picture that contains a lot of noise, this may actually make the noise worse. It is recommended to use the AUTO setting if you can.

MAX:

The level of the DigiPure effect is set to the maximum. If you set the DigiPure function to AUTO but feel that the original picture quality has not been reproduced fully, change the setting from AUTO to MAX.

- The MAX setting is not suitable for low-quality pictures which contain a lot of noise.

MIN:

The level of the DigiPure effect is set to the minimum. When you set the DigiPure function to AUTO and notice some noise, change the setting from AUTO to MIN.

- The MIN setting is not suitable for high-quality pictures which contain very little noise.

OFF:

The DigiPure function is turned off.

■ PULL DOWN

The PULL DOWN function displays a cinema film picture more smoothly and naturally on the screen.

AUTO:

This function is turned on. Normally keep this function set to AUTO.

OFF:

This function is turned off.

- The motion may appear unnatural when viewing images with the NTSC colour system. To make the motion smoother, switch the PULL DOWN function from AUTO to OFF.
- You cannot select this function in the Twin pictures mode or the Picture in picture mode.

■ COLOUR SYSTEM

The colour system is chosen automatically. However, if the picture is not clear or no colour appears, choose the colour system manually.

- 1 Choose **COLOUR SYSTEM**, then press the **MENU/OK** button.

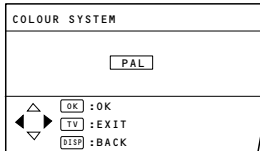

- 2 Press the **◀/▶** buttons to choose the appropriate colour system. Then press the **MENU/OK** button.

- When changing to the **COLOUR SYSTEM** of the SUB-picture, see "Change the colour system of the SUB-picture" on page 15 for details.
- You can also operate the **COLOUR SYSTEM** function with the **COLOUR SYSTEM** button on the remote control. For details, see "COLOUR SYSTEM button" on page 11.

■ ZOOM

You can change the screen size according to the picture aspect ratio. Choose the optimum one of three **ZOOM** modes.

- 1 Choose **ZOOM**, then press the **MENU/OK** button.

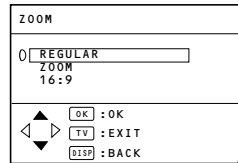

- 2 Press the **▲/▼** buttons to choose a **ZOOM** mode. Then press the **MENU/OK** button.

The picture expands and the chosen **ZOOM** mode is displayed in about 5 seconds.

- You can choose a **ZOOM** mode from **REGULAR**, **ZOOM** or **16:9** modes. For details, see "ZOOM button" on page 9.
- You cannot select the **ZOOM** function when receiving the Progressive Video Signal (525P signal).

■ PICTURE TILT

There are cases where the Earth's magnetic force may make the picture tilt. If this happens, you can correct the picture tilt.

- 1 Choose **PICTURE TILT**, then press the **MENU/OK** button.

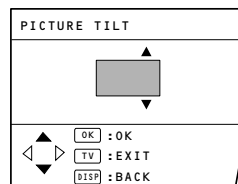

- 2 Press the **▲/▼** buttons until the picture becomes level. Then press the **MENU/OK** button.

SOUND SETTING menu

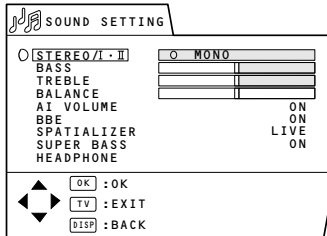

■ STEREO / I • II

When you are viewing a bilingual broadcast programme, you can choose the sound from Bilingual I (sub I) or Bilingual II (sub II). When the stereo broadcasting is received poorly, you can change from stereo to mono sound so that you can hear the broadcast more clearly and easily.

⊕ : Stereo sound

○ : mono sound

I : Bilingual I (sub I)

II : Bilingual II (sub II)

MONO: Cancels the Multi Sound function, and the sound becomes monaural.

- The sound mode you can choose differs depending on the TV programme.
- This function does not work in the VIDEO modes.

■ Adjusting the sound

You can adjust the sound to your liking.

BASS

You can adjust the low tone of the sound.

- ◀ : weaker
- ▶ : stronger

TREBLE

You can adjust the high tone of the sound.

- ◀ : weaker
- ▶ : stronger

BALANCE

You can adjust the volume balance between the left and right speakers.

- ◀ : turn the left speaker's volume level up.
- ▶ : turn the right speaker's volume level up.

■ AI VOLUME

You can prevent the sudden increase or decrease of sound that occurs when changing the channel to another channel or switching the VIDEO mode to another VIDEO mode.

ON :

This function is turned on.

OFF :

This function is turned off.

- The AI VOLUME function for TV mode and VIDEO mode can be set separately. For example, you can set it to be OFF in TV mode and ON in VIDEO mode. If you set the AI VOLUME function while viewing images from a VIDEO terminal, the setting is registered as the setting for VIDEO mode.
- The AI VOLUME function may not operate as expected if the sound input level from a broadcast station (or video software) is extremely low.

■ BBE

You can use the BBE function to enjoy easy-to-listen sound that is faithful to the original sound recorded.

ON :

This function is turned on.

OFF :

This function is turned off.

Licensed by BBE Sound, inc. BBE is a registered trademark of BBE Sound, inc.

■ SPATIALIZER

You can enjoy Surround sound with a "live" effect by using the SPATIALIZER function. You can choose one of two SPATIALIZER modes.

- You can choose a SPATIALIZER mode from LIVE, MONO or OFF modes. For details, see " SPATIALIZER button " on page 9.

The SPATIALIZER is manufactured under license from Desper Products, Inc.

■ SUPER BASS

You can enjoy a powerful bass sound by using the Super Bass (Super Bass Reflex) function.

ON :

This function is turned on.

OFF :

This function is turned off.

■ HEADPHONE

This function enables you to output the TV's sound from your headphones.

- Choose HEADPHONE, then press MENU/OK button.

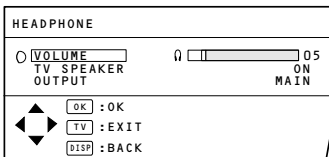

- Use the ▲/▼ button to select, and the ◀/▶ button to set the HEADPHONE function. Then press the MENU/OK button.

VOLUME :

You can adjust the volume of the sound output from your headphones.

TV SPEAKER:

When this function is on, the TV's speaker does not shut off the sound even if headphones are connected.

If you set this function to off, the TV's speaker does not output the sound when the headphones are connected.

OUTPUT:

You can choose the sound from the MAIN-picture(MAIN) or the SUB-picture(SUB) when using the headphones.

- The TV's speaker does not put out the sound from the SUB-picture.
- The sound of the SUB-picture is mono only. You cannot use the STEREO/I-II function for the sound of the SUB-picture.

FEATURES menu

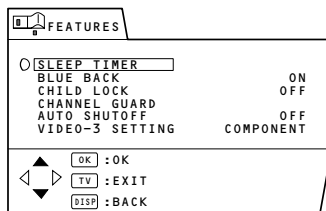

■ SLEEP TIMER

You can set the TV to automatically turn off after a set time.

- 1 Choose **SLEEP TIMER**, then press the **MENU/OK** button.

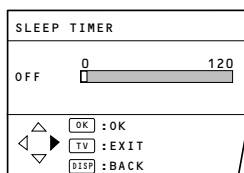

- 2 Press the **◀/▶** buttons to set the period of time.

The TV begins count down from the set time.

- You can set the period of time a maximum of 120 minutes (2 hours) in 10 minute steps.

To cancel this function:

Press the **◀** button to set a period of time to "OFF".

- 3 Press the **MENU/OK** button to complete the setting.

The menu disappears.

- One minute before this function turns off the TV, "GOOD NIGHT!" appears.
- This function cannot be used to turn off the TV's main power.
- When this function is on, you can display the **SLEEP TIMER** menu again to confirm or change the remaining time.

■ BLUE BACK

You can set the TV to automatically change to a blue screen and mute the sound if the signal is weak or absent, or when there is no input from an external device.

ON :

This function is turned on.

OFF:

This function is turned off.

■ CHILD LOCK

You can disable the front control buttons of the TV. When this function is set to ON, the TV can be operated only by using the remote control.

Use this function to prevent children from operating the TV at their own discretion (without parent consent).

ON :

This function is turned on.

OFF:

This function is turned off.

■ CHANNEL GUARD

When there is a TV channel you do not want your children to watch, you can lock out the channel. Even when a child chooses a programme number for a locked out channel the screen will change to blue and display  so the channel cannot be viewed.

To set this function

- 1 Choose **CHANNEL GUARD**, then press the number **0** (AV) button.

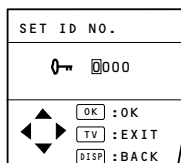

2 Set the ID number you want.

To choose a number:

Press the ▲/▼ buttons.

To move a cursor:

Press the ◀/▶ buttons.

3 Press the MENU/OK button.

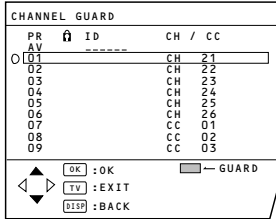

4 Press the ▲/▼ buttons to choose a TV channel.

- The TV shows the TV programme which the chosen TV channel is now broadcasting.

5 Press the blue button to set this function to the TV channel.

🔒 (CHANNEL GUARD) appears and the TV channel is locked.

To cancel this function:

Press the blue button again.

🔒 (CHANNEL GUARD) disappears and the lock is released.

6 Press the MENU/OK button to complete the setting.

The menu disappears.

To view a locked TV channel

1 Choose a programme number in which a TV channel locked with the number buttons or PR LIST.

The screen changes to blue and the 🔒 (CHANNEL GUARD) appears.

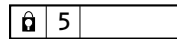

- You cannot choose a locked TV channel with the ▲/▼ buttons.

2 Press the DISPLAY button to display " ID NO. " (ID number input screen).

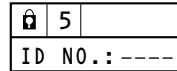

3 Press the number buttons to enter the ID number.

The lock is temporarily released so you can view the TV channel.

If you have forgotten the ID number:

Perform step 1 of "To set this function".

After confirming the ID number, press the TV/VIDEO button to exit the menu.

- When you would like to cancel the CHANNEL GUARD function, you must perform the operation " To set this function" again.

■ **AUTO SHUTOFF**

You can set your TV to turn off if no signal are received for about 15 minutes or longer after the end of a broadcast.

ON :

This function is turned on.

OFF :

This function is turned off.

- The AUTO SHUTOFF function does not turn off the TV's main power.
- The AUTO SHUTOFF will not work for a VIDEO mode.

■ **VIDEO-3 SETTING**

Set the VIDEO-3 SETTING correctly according to the video signal input from the external device connected to the VIDEO-3 terminal. If this setting is incorrect, images will not be displayed.

VIDEO :

If a normal video signal (composite video signal) is input.

COMPONENT :

If a Component video signal (Y/C_B/C_R signals) is input.

- For detailed connecting methods, see " Additional preparation " on page 36.
- This Television is compatible with the Progressive Video Signal (525P signal) only when the component video signal is input.

INSTALL menu

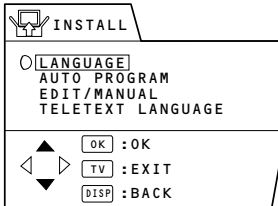

■ LANGUAGE

You can choose the language you want to use for the on-screen display from the language list in a menu.

- 1 Choose LANGUAGE, then press the MENU/OK button.

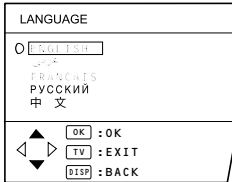

- 2 Press the ▲/▼ buttons to choose a language.
- 3 Press the MENU/OK button to complete the setting.

The menu disappears.

■ AUTO PROGRAM

You can automatically register the TV channels which can be received well at your residence in the TV's programme numbers by performing the following.

- 1 Choose AUTO PROGRAM, then press the MENU/OK button.

The AUTO PROGRAM function starts. The TV channels you receive are automatically stored in the programme numbers list.

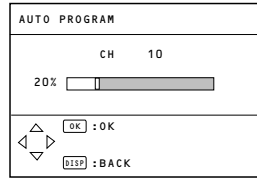

- To cancel the AUTO PROGRAM function, press the DISPLAY button.

- 2 After the TV channels have been stored in the programme number list, the EDIT menu appears.

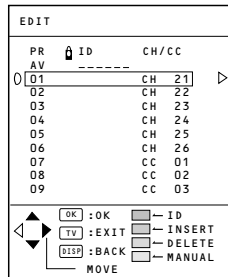

- You can proceed to edit the programme numbers list using the EDIT/MANUAL function. For details, see "EDIT/MANUAL" on page 30.
- If a TV channel you want to view is not stored in the programme numbers list, you can register it using the MANUAL function. For details, see "EDIT/MANUAL" on page 30.
- The AUTO PROGRAM function does not store a TV channel to the programme number 0 (AV).
- If you do not need to use the EDIT/MANUAL function, press the MENU/OK button to exit from the EDIT menu.

■ EDIT/MANUAL

The EDIT/MANUAL functions are divided into two types:

editing of the current programme numbers (EDIT functions) and manual registration of a TV channel you want to view to the programme number (MANUAL function).

CAUTION

- Using the MOVE, DELETE or INSERT function rewrites the current programme numbers list. Resultingly, the programme number of some of the TV channels will change.
- When a TV channel which has been locked out using the CHANNEL GUARD function, using the MANUAL function for that TV channel cancels the CHANNEL GUARD function.
- When a TV channel has already been registered in PR 99, using the INSERT function deletes the TV channel.

- 1 Choose EDIT/MANUAL, then press the MENU/OK button.

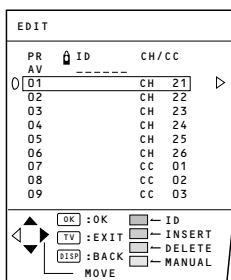

- 2 Follow the operation description of a function you want to use and operate the function.

MOVE :

This function changes a programme number of a TV channel.

ID :

This function registers a Channel name (ID) to a TV channel.

INSERT:

This function adds a new TV channel in the current programme numbers list by using the CH/CC number.

DELETE :

This function deletes a unnecessary TV Channel.

MANUAL :

This function manually registers a new TV channel in a programme number.

- 3 Press the MENU/OK button to complete the setting.

- For programme number PR 0, "AV" appears in the programme numbers list.

FUNCTIONS

MOVE

- 1 Press the ▲/▼ buttons to choose a TV channel.
- 2 Press the ► button to start the MOVE function.

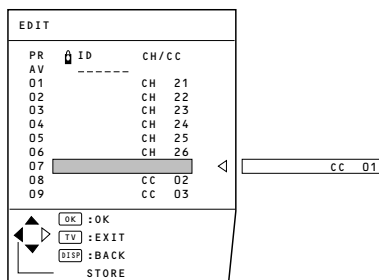

- 3 Press the ▲/▼ buttons to choose a new programme number.

To cancel the MOVE function:
Press the DISPLAY button.

- 4 Press the ◀ button to change the programme number of a TV channel to a new programme number.

ID

- 1 Press the ▲/▼ buttons to choose a TV channel.
- 2 Press the red button to start the ID function.
- 3 Enter a channel name (ID). Press the ▲/▼ buttons to choose a character. press the ◀/▶ buttons to move the cursor.

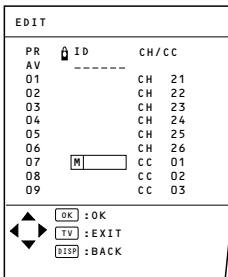

To cancel the ID function:
Press the DISPLAY button.

- 4 Press the MENU/OK button to register a channel name to a TV channel.

DELETE

- 1 Press the ▲/▼ buttons to choose a TV channel.
- 2 Press the yellow button to delete the TV channel.

The TV channel is deleted from the programme numbers list.

MANUAL

- 1 Press the ▲/▼ buttons to choose a programme number to which you want to register a new TV channel.
- 2 Press the blue button to activate the MANUAL function.

At the right side following the CH/CC number, the SYSTEM (sound system) of the TV channel appears.

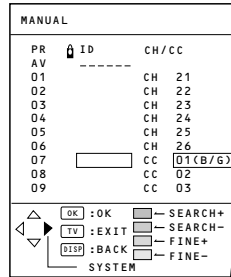

To cancel the MANUAL function:
Press the DISPLAY button.

- 3 Press the ▶ button to choose the system (sound system) for a TV channel you want to register.
 - For the sound systems in each country or region, see the table "BROADCASTING SYSTEMS" on page 12.
- 4 Press the green or red button to search for a TV channel.
- 5 Press the green or red button repeatedly until the to TV channel you want appears.

If the TV channel reception is poor:
Press the blue or yellow button to finetune the TV channel.

If you cannot hear the normal sound even when the picture of the TV channel appears normally:

The SYSTEM setting is wrong. Press the ▶ button and choose a SYSTEM that has normal sound.

- 6 Press the MENU/OK button and register the TV channel to a programme number.
The normal EDIT menu is resumed.

INSERT

PREPARATION

- Find the CH/CC number corresponding to the channel number of the TV channel from the on page 33.
- 1 Press the ▲/▼ buttons to choose a programme number for which you will register a new TV channel.
 - 2 Press the green button to start the INSERT function.

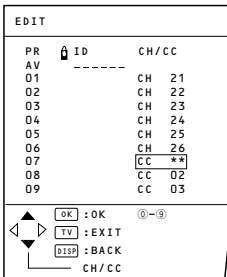

- 3 Press the ▲/▼ buttons to choose "CC" or "CH" according to the CH/CC number of the TV channel.

To cancel the INSERT function:
Press the DISPLAY button.

- 4 Press the Number buttons to enter the remaining CH/CC number.

The TV shifts to registration mode.
When the registration is completed, the picture of the TV channel appears on the screen.

- The CH/CC number is a number indicating the broadcast frequency to the TV. If the TV cannot detect the TV channel corresponding to the broadcast frequency indicated by the CH/CC number, a picture in the no-signal state appears.

CH/CC number

When you want to use the INSERT function on page 32, find the CH/CC number corresponding to the Channel number of the TV channel from this table.

US : The US channel numbers are the channel numbers used in the United States, Philippines, etc.

CCIR: The CCIR channel numbers are the channel numbers used in the Middle East, Southeast Asia ,etc.

OIRT: The OIRT channel numbers are the channel numbers used in Eastern Europe,Russia, Vietnam, etc.

AUSTRALIA: The AUSTRALIA channel numbers are the channel numbers used in Australia, etc.

CH	Channel			
	US	CCIR	OIRT	AUSTRALIA
CH 02	US-2	E2	R1	AU-0
CH 03	US-3	E3		AU-1
CH 04	US-4	E4	R2	AU-2
CH 05	US-5	E5	R6	AU-6
CH 06	US-6	E6	R7	AU-7
CH 07	US-7	E7	R8	AU-8
CH 08	US-8	E8	R9	AU-9
CH 09	US-9	E9		
CH 10	US-10	E10	R10	AU-10
CH 11	US-11	E11	R11	AU-11
CH 12	US-12	E12	R12	
CH 13	US-13			
CH 14	US-14			
CH 15	US-15			
CH 16	US-16			
CH 17	US-17			
CH 18	US-18			
CH 19	US-19			
CH 20	US-20			
CH 21	US-21	E21		
CH 22	US-22	E22		
CH 23	US-23	E23		
CH 24	US-24	E24		
CH 25	US-25	E25		
CH 26	US-26	E26		
CH 27	US-27	E27		
CH 28	US-28	E28		
CH 29	US-29	E29		
CH 30	US-30	E30		
CH 31	US-31	E31		
CH 32	US-32	E32		
CH 33	US-33	E33		
CH 34	US-34	E34		
CH 35	US-35	E35		
CH 36	US-36	E36		
CH 37	US-37	E37		
CH 38	US-38	E38		
CH 39	US-39	E39		
CH 40	US-40	E40		
CH 41	US-41	E41		
CH 42	US-42	E42		
CH 43	US-43	E43		
CH 44	US-44	E44		
CH 45	US-45	E45		
CH 46	US-46	E46		
CH 47	US-47	E47		
CH 48	US-48	E48		
CH 49	US-49	E49		
CH 50	US-50	E50		
CH 51	US-51	E51		
CH 52	US-52	E52		
CH 53	US-53	E53		
CH 54	US-54	E54		
CH 55	US-55	E55		
CH 56	US-56	E56		
CH 57	US-57	E57		
CH 58	US-58	E58		
CH 59	US-59	E59		
CH 60	US-60	E60		
CH 61	US-61	E61		
CH 62	US-62	E62		
CH 63	US-63	E63		
CH 64	US-64	E64		
CH 65	US-65	E65		
CH 66	US-66	E66		
CH 67	US-67	E67		
CH 68	US-68	E68		
CH 69	US-69	E69		
CH 70				

CC	Channel			
	US	CCIR	OIRT	AUSTRALIA
CC 01		S-1		AU-5
CC 02		S-2		
CC 03		S-3		
CC 04		S-4		
CC 05		S-5		
CC 06		S-6		AU-5A
CC 07		S-7		
CC 08		S-8		
CC 09		S-9		
CC 10		S-10		
CC 11		S-11		
CC 12		S-12		
CC 13		S-13		
CC 14	A	S-14		
CC 15	B	S-15		
CC 16	C	S-16		
CC 17	D	S-17		
CC 18	E	S-18		
CC 19	F	S-19		
CC 20	G	S-20		
CC 21	H	S-21		
CC 22	I	S-22		
CC 23	J	S-23		
CC 24	K	S-24		
CC 25	L	S-25		
CC 26	M	S-26		
CC 27	N	S-27		
CC 28	O	S-28		
CC 29	P	S-29		
CC 30	Q	S-30		
CC 31	R	S-31		
CC 32	S	S-32		
CC 33	T	S-33		
CC 34	U	S-34		
CC 35	V	S-35		
CC 36	W	S-36		
CC 37	W+1	S-37		
CC 38	W+2	S-38		
CC 39	W+3	S-39		
CC 40	W+4	S-40		
CC 41	W+5	S-41		
CC 42	W+6			
CC 43	W+7			
CC 44	W+8			
CC 45	W+9			
CC 46	W+10			
CC 47	W+11			
CC 48	W+12			
CC 49	W+13			
CC 50	W+14			
CC 51	W+15			
CC 52	W+16			
CC 53	W+17			
CC 54	W+18			
CC 55	W+19			
CC 56	W+20			
CC 57	W+21			
CC 58	W+22			
CC 59	W+23			
CC 60	W+24			
CC 61	W+25			
CC 62	W+26			
CC 63	W+27			
CC 64	W+28			
CC 75		X		
CC 76		Y	R3	
CC 77		Z	R4	AU-3
CC 78		Z+1	R5	
CC 79		Z+2		AU-4
CC 95	A-5			
CC 96	A-4			
CC 97	A-3			
CC 98	A-2			
CC 99	A-1			

■ TELETEXT LANGUAGE

There are 4 types of teletext language groups. Set the teletext language group that corresponds to the language of the teletext program that you want to watch.

- Languages that are not included in the teletext language group that you select, the sub-titles of the teletext program will not be displayed properly.

- 1 Choose TELETEXT LANGUAGE, then press the MENU/OK button.

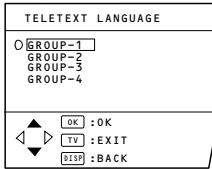

- 2 Press the ▲/▼ buttons to choose a group.

Group	Languages
GROUP-1	Turkish, Hungarian, English, German, French, Italian, Spanish, Portuguese, Greek, Swedish, Finnish
GROUP-2	Polish, Serbian, Croatian, Slovenian, Czech, Slovak, Rumanian, Hungarian, German, French, Italian, Swedish, Finnish
GROUP-3	Russian, Bulgarian, Lettish, Lithuanian, Estonian, Ukrainan, Serbian, Croatian, Slovenian, Czech, Slovak, English, German
GROUP-4	Arabic, Czech, Slovak, Hungarian, English, German, French, Italian, Spanish, Portuguese, Swedish, Finnish

- 3 Press the MENU/OK button to complete the setting.

The menu disappears.

DEMO menu

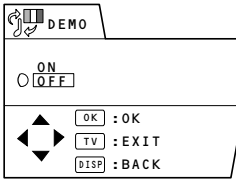

The DEMO function automatically demonstrates some of the TV function.

When the DEMO function is set to ON:

Each time the TV is turned on, the demonstration starts automatically.

If you do not want that to happen, set the DEMO function to OFF.

- 1 Press the ▲/▼ buttons to choose ON.

To cancel the DEMO function, choose off.

- 2 Press the MENU/OK button to complete the settings.

The DEMO function is set to ON, and the demonstration will start.

To stop the demonstration:

Press one of the buttons on the remote control.

Additional preparation

■ Connecting the external devices

Connect the devices to the TV, paying attention to the following connection diagram.

Before connecting anything:

- Read the manuals provided with the devices. Depending on the devices, the connection method may differ from the figure. In addition, the device settings may be changed depending on the connection method to secure proper operation.
- Turn off all the devices including the TV.
- The "Specifications" on page 43 contains the details of the VIDEO terminals. If you are connecting a device not listed in the following connection diagram, see the "Specifications" to choose the best VIDEO terminal.
- Note that connecting cables are not supplied.
- When connecting devices that are supported by AV COMPU LINK, see "Connecting AV COMPU LINK Supported Devices" on page 38.

- ① VCR (composite signal)
- ② VCR (S-VIDEO signal; Y/C)
- ③ VCR for recording (composite signal)
- ④ DVD player (composite signal)
- ⑤ DVD player (S-VIDEO signal; Y/C)
- ⑥ DVD player (component video signals; Y/C_B/C_R)
- ⑦ TV game (composite signal)
- ⑧ TV game (S-VIDEO signal; Y/C)
- ⑨ Camcorder (composite signal)
- ⑩ Camcorder (S-VIDEO signal; Y/C)
- ⑪ Headphones

- Ⓐ AV COMPU LINK cable

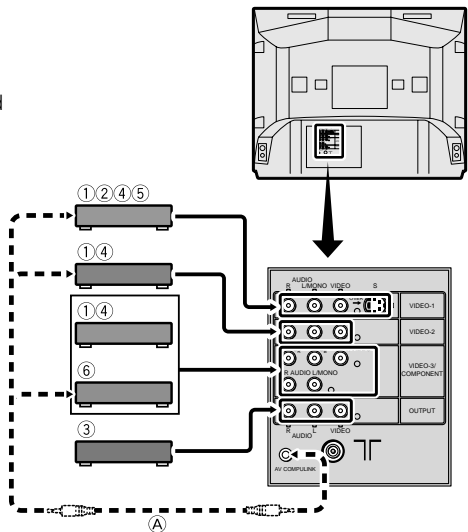
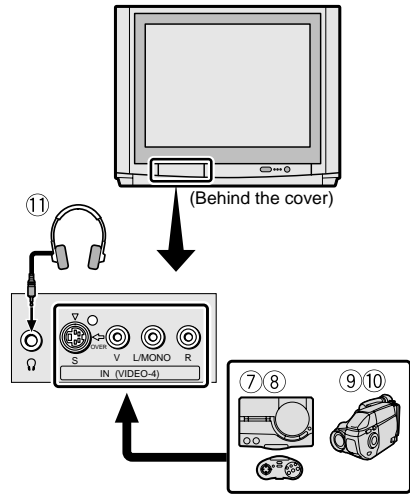

Connecting methods

- 1 Connect the TV's VIDEO jack and the device's VIDEO OUT (video output) jack with a video cable.

If connecting a device to the TV with an S-VIDEO cable :

Connect the VCR's S-VIDEO OUT (S-VIDEO output) connector and the TV's "S" (S-VIDEO) connector with an S-VIDEO cable, instead of connecting with a video cable.

Note that the connection with a video cable will be ignored in case you connect a VCR to the TV with both video cable and S-VIDEO cable.

If connecting a DVD player to the TV with a component video cable:

Connect three jacks (Y/VIDEO, C_B and C_R) in the VIDEO-3 terminal and the DVD player's COMPONENT (component video output) jacks with a component video cables, instead of connection with a video cable. Then set the VIDEO-3 SETTING to COMPONENT, according to "VIDEO-3 SETTING" on page 28.

- This Television is compatible with the Progressive video signal (525P signal). (When the component video signal is input.)

If you have a DVD player that outputs Progressive video signals (525P) as a component video signal, then by attaching the device to the television with a component video cable you can see the actual images that are recorded on a DVD disc as an original image source.

If connecting a device to the VIDEO-3/COMPONENT terminal with a video cable:

Connect the TV's Y/VIDEO jack and the device's VIDEO OUT (video output) jack with a video cables.

Then set the VIDEO-3 SETTING to VIDEO according to "VIDEO-3 SETTING" on page 28.

- In the VIDEO-4 terminal, the VIDEO jack is indicated by "V".
- 2 Connect the TV's AUDIO jacks (L/MONO and R) and the device's AUDIO OUT (audio L/R output) jacks with an audio cable.

If the device's sound output is in mono :

Connect the device's AUDIO OUT jack and the TV's L/MONO jack with an audio cable.

Connecting devices to the OUTPUT terminal

The signals of the images and sound you are currently viewing with this TV are output through the OUTPUT terminal. By connecting a VCR to the OUTPUT terminal, you can record the currently shown image and sound to that VCR. To do this, connect the VCR and OUTPUT terminal following the steps below.

- 1 Connect the VIDEO jack in the OUTPUT terminal and the VCR's VIDEO IN (video input) jack with a video cable.
- 2 Connect the AUDIO jacks (L and R) in the OUTPUT terminal and the VCR's AUDIO IN (audio L/R input) jacks with an audio cable.
 - When you turn off the TV, the signals from the OUTPUT terminal are also turned off.
 - The component signals input from the VIDEO-3/COMPONENT terminal cannot be output through the OUTPUT terminal.

Connecting Headphones

Connect the headphones with a stereo mini jack (of 3.5 mm in diameter) to the Headphone jack at the TV front panel.

■ Connecting AV COMPU LINK Supported Devices

AV COMPU LINK remote control system is a system in which related devices are automatically controlled when you operate one device.

If you apply this system to the TV, you can have the TV automatically perform the required operations by operating one external device. You don't have to use the TV's remote control to turn on the TV or change the VIDEO modes.

Examples of the AV COMPU LINK remote control system operations

Simply by pressing the PLAY button on a VCR or a DVD player, you can view images from the device.

Simply by inserting a pre-recorded tape (a tape with the record safety tab removed) to a VCR, you can view the tape.

Simply by operating the AV Control Receiver, you can have the TV turned on/off (in standby mode) or the VIDEO mode changed correctly.

- The performance of the AC COMPU LINK remote control system varies depending on the connected device. See the device's instruction manual.
- When you select "TV SOUND" as the input source with the AV Control Receiver, there are cases where the TV's MUTING function automatically operates and the sound from the TV's speakers is muted.
In such cases, press the VOLUME-/+ buttons or the MUTING button on the TV's remote control to cancel the MUTING function. You can regain the sound from the TV's speakers.

Conditions to use the AV COMPU LINK remote control system

- A device equipped with an AV COMPU LINK terminal is required.
- You must connect the TV and the device with an AV COMPU LINK cable. AV COMPU LINK cable is not supplied with this TV. If an AV COMPU LINK cable is unavailable, connect them with a cable with dia. 3.5 mm (mono) male plugs at both ends.
- You must connect the device to an appropriate VIDEO terminal and set it up correctly. Otherwise the AV COMPU LINK remote control system will not function correctly. For details, see "Setting up the AV COMPU LINK remote control system".
- The TV must be in standby mode (the POWER lamp lighting red). If the TV's Main power is off (the POWER lamp off), the AV COMPU LINK remote control system does not function.

Setting up the AV COMPU LINK remote control system

CAUTION:

- With some devices, the setup method differs from the ones explained here. Be sure to read the device's instruction manual thoroughly before setting it up.

- 1 Connect the device to the TV's VIDEO-1 or VIDEO-2 terminal.

If you want to connect a DVD player to the TV with a component video cable :

Connect the DVD player to the TV's VIDEO-3 terminal.

- For detailed connecting instructions, see "Connecting the external devices" on page 36.

- 2 Connect the TV's AV COMPU LINK terminal and the device's AV COMPU LINK terminal with an AV COMPU LINK cable.
- 3 Change the device's setting according to the VIDEO terminal it is connected to.

If a VCR is connected to the VIDEO-1 terminal :

Set the VCR's remote control code to A code.

If a DVD player is connected to the VIDEO-1 terminal:

Set the DVD player's AV COMPULINK MODE to DVD2.

If a VCR is connected to the VIDEO-2 terminal:

Set the VCR's remote control code to B code.

If a DVD player is connected to the VIDEO-2 terminal:

Set the DVD player's AV COMPULINK MODE to DVD3.

If a DVD player is connected to the VIDEO-3 terminal with a component video cable:

Set the DVD player's AV COMPULINK MODE to DVD1.

- For instructions on how to change the device's setting, refer to the device's instruction manual.
- If the device you are connecting has neither the remote control code nor the AV COMPULINK MODE, then connect it to the TV's VIDEO-1 terminal.

Troubleshooting

If a problem arises while you are using the TV, please read this "Troubleshooting" well before you request having the TV repaired. You may be able to fix it easily by yourself. For example, if the AC plug is disconnected from the AC outlet, or the TV aerial has problems, you may think there is a problem with the TV itself.

Important:

- This Troubleshooting guide only covers problems whose cause are not easy to determine. If a question arise when you are operating a function, read the page(s) corresponding to the operation of the function well, not this Troubleshooting guide.
- After you have followed the Troubleshooting description or the operating description of the functions concerned without any success, remove the AC plug from the AC outlet and request a repair of your TV. Do not attempt to repair the TV by yourself or remove the rearcover of the TV.

■ If you cannot turn on the TV

- Is the AC plug connected to the AC outlet?
- Is the POWER lamp lit? If not, press the Main power button.

■ No picture/No sound

- Have you chosen a TV channel whose reception is extremely bad? In this case, the BLUE BACK function will be activated, the entire screen becomes blue, and the sound is muted. In spite of this, if you want to view the TV channel, follow the description "BLUE BACK" on page 26 to try to change the BLUE BACK function setting to OFF.
- Are your SOUND SYSTEM settings for the TV channels correct? Follow the description "SOUND SYSTEM Button" on page 12 to try to solve the trouble.

■ Poor picture

- If noise totally obscures the picture (snow), the aerial or aerial cable may have trouble. Check the following to try to solve the trouble :

Has the TV and aerial been connected properly?

Has the aerial cable been damaged?
Is the aerial pointed to the right direction?

Is the aerial itself faulty?

- If the TV or aerial receives interference from the other devices, stripes or noise may appear in the picture. Move such device as an amplifier, personal computer, or a hair drier that can cause interference away from your TV, or try changing its location. If the aerial suffers interference from a radio tower or high-voltage wire, please contact your local dealer.
- If the TV receives interferences from signal reflecting from mountains or building, double-pictures(ghosting) will occur.
Try to change the aerial's direction or replace the antenna with the one with better directionality.
- Are your COLOUR SYSTEM settings for the TV channels correct? Follow the description "COLOUR SYSTEM button" on page 11 to try to solve the trouble.
- Has COLOUR or BRIGHT been controlled properly? Follow the description "Adjusting the picture" on page 20 to try to adjust them properly.
- Videotaping teletext is not recommended because it may not record correctly.

- When a white and bright still image (such as a white dress) is displayed on the screen, the white part may look as if it were coloured.

It is a phenomenon unavoidable due to the nature of the picture tube itself, and not due to a TV failure.

When the picture disappears from the screen, the unnatural colours will also disappear.

- When viewing images from commercially available video software products, or videos from videotapes which have been recorded improperly, the top of the image may be distorted.

This is due to the condition of the video signal, and not because of malfunction.

■ Poor sound

- Have you adjusted BASS or TREBLE properly? If not, follow the description "Adjusting the Sound" on page 24 to try to adjust them properly.
- When the TV channel reception is poor, it can be hard to hear the stereo or bilingual sound. In this case, follow the description "STEREO / I • II" on page 24 to hear the sound more easily by changing it to a mono sound.

■ Operation disabled

- Have the batteries of the remote control become exhausted?
Follow the description "Putting the Batteries into the Remote Control" on page 4 and replace them with new batteries to try to solve the problem.
- Have you attempted to use the remote control at the sides or rear of the TV or at a location more than seven meters apart from the TV location? Operate the remote control in the front of your TV or a location less than seven meters from your TV to try to solve the problem.

- When you are viewing a teletext programme, you cannot operate the menus. Press the TV/VIDEO button to return the teletext programme to the ordinary TV programme to try operating the menus.

- Is the CHILD LOCK function set to ON? If the CHILD LOCK function is set to ON, you cannot operate the TV with the front control buttons of the TV. Follow the description "CHILD LOCK" on page 26 to try to set the CHILD LOCK function to OFF.

- If the TV operation becomes disabled suddenly, press the Main power button on the TV and turn off the main power. Try to press the Main power button again to turn on the main power. If the TV returns to a normal state, it is not a failure.

- The following functions do not operate when receiving Progressive Video Signal (525P signal);

Remote control function:

ZOOM, PIP, MULTI, FREEZE and STROBE BUTTON

MENU function:

SHARP, TINT, DIGITAL VNR, Digipure and ZOOM

■ Other concerns

- When the SLEEP TIMER function or AUTO SHUTOFF function operates, the TV is automatically turned off. If the TV is turned off suddenly, try to press the POWER button to turn on the TV once again. At this time, if the TV resumes a normal state, there is no problem.
- If you do not want sound emitted from the TV's speakers when using headphones, change the TV SPEAKER setting in the HEADPHONE menu to OFF. For details, see "HEADPHONE" on page 25.

Troubleshooting

- If you bring a magnetised device such as a speaker near to your TV, a picture may be warped or unnatural colours appear at the corners of the screen. In this case, keep the device apart from your TV. If the speaker causes such phenomena, use the magnetic-shielded speaker instead.
- A picture may be tilted due to the influence of the earth's magnetism. In this case, use the "PICTURE TILT" on page 23 to complete the tilt.
- It takes a short period of time from the time an operation such as changing channels is performed until an image is displayed. This is not a malfunction. This is the time required for the image to stabilize before it can be displayed.
- The TV may emit a crackling sound due to a sudden change in temperature. It does not matter if a picture or sound does not show any abnormality. If you hear crackling sounds frequently while you are viewing the TV, other causes may be assumed.
For precautionary purposes, request your service technician to inspect it.
- Touching the screen may cause you feel a slight electric shock due to its static electricity.
It is an unavoidable phenomenon due to the construction of the picture tube. It is not a problem with the TV.
You can rest assured that this static discharge does not have harmful influence over the human body.

Specifications

Broadcasting systems	B, G, I, D, K, K1, M
Colour systems	PAL, SECAM, NTSC3.58/4.43MHz
Channels and frequencies	VHF low channel (VL) =46.25 to 168.25 MHz VHF high channel (VH) =175.25 to 463.25 MHz UHF channel (U) =471.25 to 863.25 MHz ■ Receives cable channels in mid band (X to Z+2, S1 to S10), super band (S11 to S20) and hyper band (S21 to S41).
Sound-multiplex systems	A2 (B/G), NICAM (B/G, I, D/K) system
Teletext systems	FLOF(Fasttext), WST(World Standard Text)
Lauguages displayed by teletext	Please see the table in the description "TELETEXT LANGUAGE" on page 34
Power requirements	AC 110 to 240V, 50/60Hz
Audio output	Rated Power output: 20W + 20W
VIDEO-1 terminal	RCA connector X 3, S-VIDEO connector X 1 • Video input, S-VIDEO (Y/C) input and Audio L/R inputs are available.
VIDEO-2 terminal	RCA connector X 3 • Video input and Audio L/R inputs are available.
VIDEO-3/COMPONENT terminal	RCA connector X 5 • Video input/Component video (Y/C _B /C _R) input and Audio L/R inputs are available. • Progressive video signal(525P signal) input is available.
VIDEO-4 terminal	RCA connector X 3, S-VIDEO connector X 1 • Video input, S-VIDEO (Y/C) input and Audio L/R inputs are available.
OUTPUT terminal	RCA connector X 3 • Video output and Audio L/R outputs are available.
Headphone jack	Stereo mini-jack (3.5 mm in diameter)
Accessories	Remote control unit X 1 (RM-C214) AA/R6 dry cell battery X 2
Speakers	HV-34LPZ : 12cm round X 2, 3.5cm round X 2 HV-29LPZ : 10cm round X 2, 3.5cm round X 2
Power consumption	HV-34LPZ : Maximum 255W Average 170W HV-29LPZ : Maximum 254W Average 170W
Screen size (measured diagonally)	HV-34LPZ : Picture tube 87cm Visible area 80cm HV-29LPZ : Picture tube 73cm Visible area 68cm
Dimensions(W X H X D)	HV-34LPZ : 898mm X 728mm X 579mm HV-29LPZ : 732mm X 588mm X 518mm
Weight	HV-34LPZ : 75kg HV-29LPZ : 48kg

Design and specifications subject to change without notice.

Pictures displayed on the screen using this TV's ZOOM functions should not be shown for any commercial or demonstration purpose in public places (cafes,hotels, etc.) without the consent of the owners of copyright of the original picture sources, as this constitutes an infringement of copyright.

This TV does not conform to the PAL-D Chinese broadcasting system.

此种电视机不适用于PAL-D中国广播制式。

HV-34LPZ / HV-29LPZ

JVC

VICTOR COMPANY OF JAPAN, LIMITED

JVC



COLOUR TELEVISION

HV-34LPZ HV-29LPZ

InteriArt
Premiere

DigiPure

100Hz & PROGRESSIVE SCAN

Contents

Setting up your TV	3
TV buttons and functions	6
Remote control buttons and functions	8
Using the TV's menu	16
Basic operation	16
PICTURE SETTING menu	18
PICTURE FEATURES menu	19
SOUND SETTING menu	22
FEATURES menu	24
INSTALL menu	27
DEMO menu	32
Additional preparation	33
Troubleshooting	37
Specifications	40



INSTRUCTIONS



Thank you for buying this JVC colour television.

To make sure you understand how to use your new TV, please read this manual thoroughly before you begin.

WARNING:

TO PREVENT FIRE OR SHOCK HAZARD, DO NOT EXPOSE THIS APPLIANCE TO RAIN OR MOISTURE.

CAUTION:

TO ENSURE PERSONAL SAFETY, OBSERVE THE FOLLOWING RULES REGARDING THE USE OF THIS TV.

- 1 Operate only from the power source indicated on the rear of the TV.
- 2 Avoid damaging the power cord and mains plug. When unplugging the TV, grasp the mains plug. Do not pull on the power cord.
- 3 Never block or cover the ventilation openings.
Never install the TV where good ventilation is unattainable.
When installing this TV, leave spaces for ventilation around the TV of more than the minimum distances as shown.

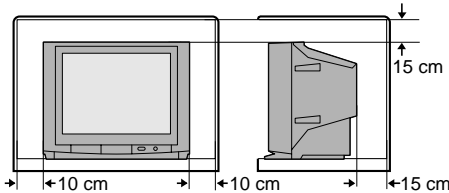

- 4 Do not allow objects or liquid into the cabinet openings.
- 5 In the event of a fault, unplug the unit and call a service technician.
Do not attempt to repair it yourself or remove the rear cover.
- 6 The surface of the TV screen is easily damaged. Be very careful with it when handling the TV. Should the TV screen become soiled, wipe it with a soft dry cloth. Never use rub it forcefully.
Never use any cleaner or detergent on it.
- 7 If you are not going to use this TV for a long period of time, be sure to disconnect the AC plug from the AC socket.

Setting up your TV

CAUTION

- Turn off all the equipment including the TV before connecting anything.

1 Connecting the aerial and VCR

- Aerial cable is not supplied. Use a good quality 75-ohm coaxial cable.
- Read the manual that came with the VCR before connecting.

If not connecting a VCR (see fig.A) :

Connect an aerial cable to the aerial socket on this TV .

If connecting a VCR (see fig.B) :

- 1 Connect the aerial cable to the aerial socket on the VCR, and connect the VCR and TV with another aerial cable.
- 2 Connect the VCR's VIDEO OUT (video output) jack and the TV's VIDEO jack with a video cable.

To connect a VCR to the TV with an S-VIDEO cable:

Connect the VCR's S-VIDEO OUT (S-VIDEO output) connector and TV's S connector with an S-VIDEO cable (A), instead of connecting with a video cable.

- 3 Connect the VCR's VIDEO OUT (audio L/R output) jacks and the TV's AUDIO jacks (L/MONO and R) with an audio cable.

- If the VCR's audio output is in mono, connect the VCR's AUDIO OUT (audio output) jack and the TV's AUDIO L/MONO jack with an audio cable.
- You can use the AV COMPU LINK function if your VCR has an AV COMPU LINK terminal. For details, see "Connecting AV COMPU LINK Supported Devices" on page 35.

Fig.A

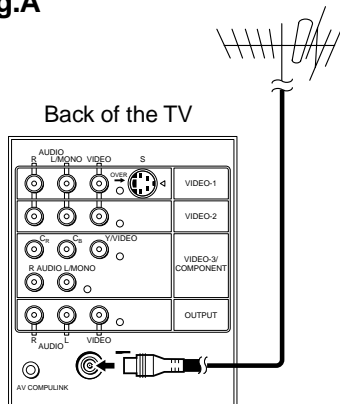
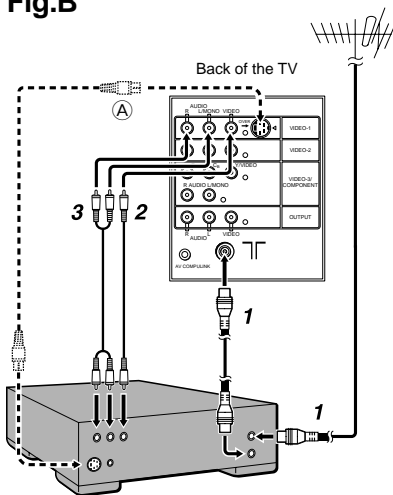

Fig.B



2 Connecting the power cord

Connect the mains plug to the AC outlet.

3 Putting the batteries into the Remote control

Use two AA/R6 batteries.

Insert the batteries from the ⊖ end, making sure the ⊕ and ⊖ polarities are correct.

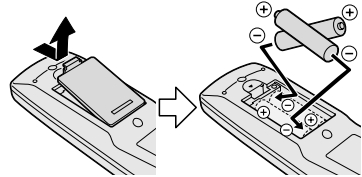

- Follow the warnings printed on the batteries.
- If the remote control does not work properly, replace the batteries.
- The batteries we supply are only for setting up and testing your TV. Please replace them as soon as necessary.

4 Making the initial settings

When the TV is first turned on, it enters the initial setting mode, and the JVC logo is displayed.

1 Press the main power button on the TV

The TV is turned on, and the JVC logo appears.

- If the power lamp on the TV lights red and does not change to green, your TV is in the standby mode. Press the POWER button on the remote control to turn the TV on.
- If the JVC logo does not appear, your TV has already been turned before. In this case, use the "LANGUAGE" and "AUTO PROGRAM" functions to make the initial settings. For details, see "INSTALL menu" on page 27.

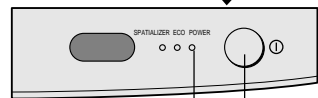
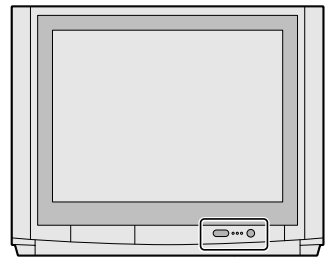

POWER lamp

Main power button

2 Press the MENU/OK button

The LANGUAGE menu appears. You can choose a language for the on-screen language.

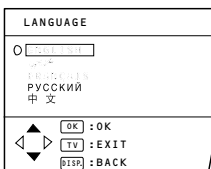

- 3 Press the ▲/▼ buttons to choose ENGLISH. Then press the MENU/OK button.

The AUTO PROGRAM function starts. The TV channels you receive are automatically stored in the programme numbers list.

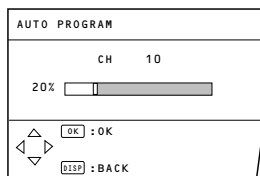

- To cancel the AUTO PROGRAM function, press the DISPLAY button.

- 4 After the TV channels have been stored in the programme number (PR) list, the EDIT menu appears.

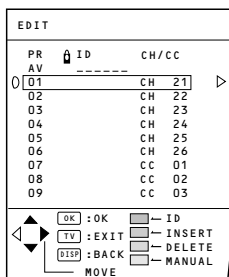

- You can proceed to edit the programme numbers list using the EDIT/MANUAL function. For details, see "EDIT/MANUAL" on page 28.
- If a TV channel you want to view is not stored in the programme numbers list, you can register it using the MANUAL function. For details, see "EDIT/MANUAL" on page 28.
- The AUTO PROGRAM function does not store a TV channel to the programme number 0 (AV).
- If you do not need to use the EDIT/MANUAL function, press the MENU/OK button to close the EDIT menu.

Now, the setting up is complete. Please enjoy your new JVC TV!

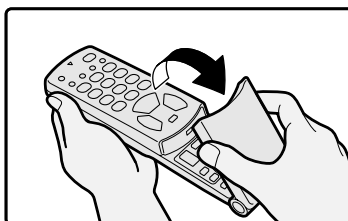
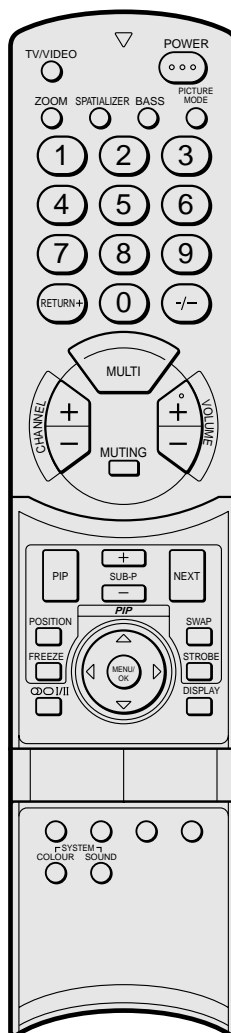

TV buttons and functions

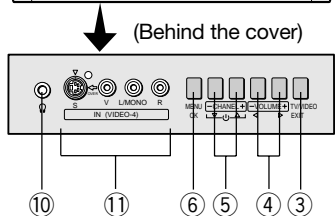
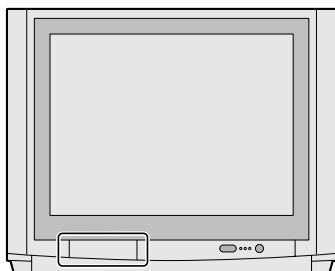
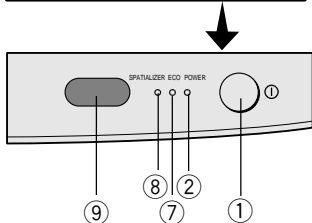
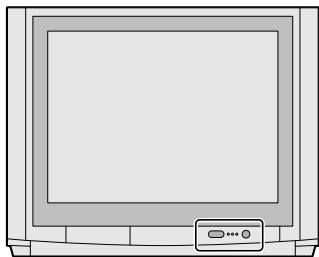

Turn the main power on

Press the main power button ① .

The POWER lamp ② lights red and your TV is in the standby mode.

To turn the main power off :
press the main power button again.
The POWER lamp ② goes off.

Turn the TV on from standby mode

Press the CHANNEL-/+ buttons ⑤ .

The POWER lamp ② lights red to green and your TV will be turned on.

- You can also turn on the TV by pressing the TV/VIDEO button ③ while it is in standby mode.

Choose a TV channel

Press the CHANNEL-/+ buttons ⑤ .

Choose a VIDEO terminal

Press the TV/VIDEO button ③ or CHANNEL-/+ buttons ⑤ .

Adjust the volume

Press the VOLUME-/+ buttons ④ .

The volume level indicator appears.

MENU button ⑥

Press to open the menu.

For details, see "Operation with the buttons on the TV" on page 17.

Remote control sensor and ECO sensor ⑨

ECO lamp ⑦

If you set the DIGITAL ECO SENSOR function to ON or DISPLAY, the ECO lamp lights.

SPATIALIZER lamp ⑧

If you set the SPATIALIZER function to MONO or LIVE, the SPATIALIZER lamp lights.

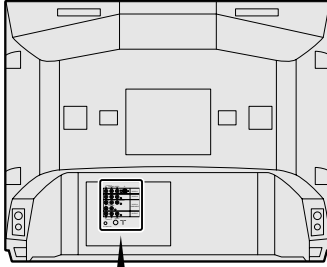

Headphone jack ⑩

Connect the headphones with a stereo mini-jack (3.5mm in diameter). When using the headphones, follow the operation procedure "HEADPHONE" on page 23.

VIDEO-1 terminal ⑫

- See page 3 and 33.

VIDEO-2 terminal ⑬

- See page 33.

VIDEO-3/COMPONENT terminal ⑭

- See page 26 and 33.

VIDEO-4 terminal ⑪

- See page 33.

OUTPUT terminal ⑮

- See page 33.

Aerial socket ⑯

Connect the aerial cable.

- See page 3.

AV COMPU LINK terminal ⑰

- See page 33 and 35.

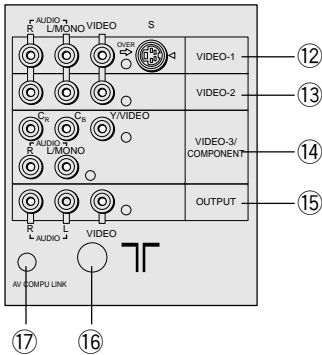

Remote control buttons and functions

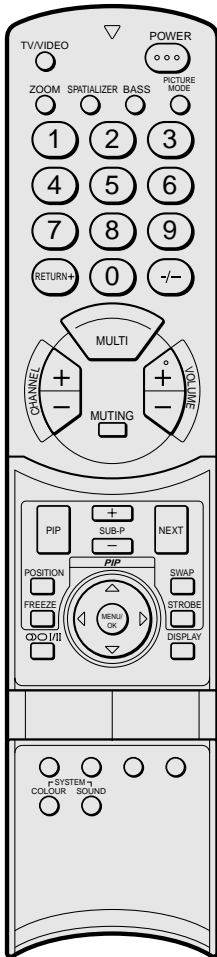

Turn the TV on from standby mode

Press the POWER button.

The POWER lamp lights red to green and your TV will be turned on.

- You can turn on the TV from the standby mode by pressing the TV/VIDEO button, the CHANNEL +/- buttons or the number buttons.

To turn the TV off:

Press the POWER button again.

The POWER lamp changes from green to red and the TV enters standby mode.

Choose a TV channel

Choose a programme number in which a TV channel has been set.

Press the CHANNEL +/- buttons or enter the programme number (PR) with the number buttons.

- If you want to put a two-digit channel into the TV, press the -/--button to change to the two-digit entry system.
- You can select a channel from the PR LIST. For details, see "DISPLAY button" on page 11.
- If you do not have a clear picture or no colour appears, follow the operation procedure "COLOUR SYSTEM button" on page 11.
- If you cannot hear sound normally even when the picture appears normally, follow the operation procedure "SOUND SYSTEM button" on page 12.

Adjust the volume

Press the VOLUME +/- buttons.

- You cannot adjust the volume of your headphones. Follow the operation procedure "HEADPHONE" on page 23.

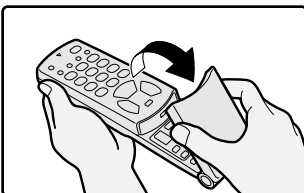

Watch images from external devices

Choose a VIDEO terminal to which the external device has been connected.

Press the TV/VIDEO button.

- You can choose a VIDEO terminal with the CHANNEL +/- buttons or from the PR LIST.

To return to a TV channel:

Press the TV/VIDEO button, the CHANNEL +/- buttons or the number buttons.

MUTING button

Press the MUTING button to turn off the volume. Pressing the MUTING button again resumes the previous volume level.

ZOOM button

You can change the screen size according to the picture aspect ratio. Choose the optimum one from the following ZOOM modes.

Press the ZOOM button to choose a mode.

- If you press the ZOOM button when receiving the Progressive Video Signal (525P signal), "525P" appears on the screen and the ZOOM function does not operate.

REGULAR

Use to view a normal picture (4:3 aspect ratio) as its original size is.



ZOOM

You can zoom up the Wide picture (16:9 aspect ratio) to fill the TV screen.



- The left side and right side of the Wide picture (16:9 aspect ratio) will be cut off.

16:9

This mode converts a normal picture (4:3 aspect ratio) into a Wide picture (16:9 aspect ratio).

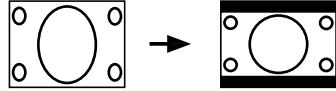

- Use for picture with a 16:9 aspect ratio that have been squeezed into a normal picture (4:3 aspect ratio), you can restore their original dimensions.

SPATIALIZER button

You can enjoy Surround sound with a "live" effect by using the SPATIALIZER function.

Press the SPATIALIZER button to choose a mode.

LIVE :

Live allows you to enjoy normal stereo sound converting it into surround sound with added depth and ambience.

MONO :

Mono allows you to enjoy normal monaural sound by converting it into a stereo-like sound.

OFF :

This function is turned off.

- The LIVE mode works properly only with stereo sound.
- The LIVE mode does not work correctly with headphones.
- The MONO mode works properly only with monaural sound.

The SPATIALIZER is manufactured under license from Desper Products, Inc.

BASS button

You can enjoy a powerful bass sound by using the SUPER BASS(Super Bass Reflex) function.

Press the BASS button to turn the SUPER BASS function on or off.

ON :

This function is turned on.

OFF :

This function is turned off.

PICTURE MODE button

You can choose one of three PICTURE MODEs (three kinds of picture setting) to adjust the picture settings automatically.

Press the PICTURE MODE button choose a mode.

BRIGHT :

Heightens contrast and sharpness.

STANDARD :

Standardizes picture adjustment.

SOFT :

Softens contrast and sharpness.

RETURN+ button

The RETURN+ button has two functions; the RETURN+ function and the RETURN function. If a channel has been registered as the "Return Channel", the RETURN+ function operates. If there is no setting for the "Return Channel", the RETURN function operates.

RETURN+ function :

By registering a channel you frequently view as the "Return Channel", you can select that channel at any time simply by pressing the RETURN+ button.

To register a TV channel as the "Return Channel" :

Choose the Programme number to which the channel you want to register has been set, and press the RETURN+ button and hold for more than 3 seconds continuously. "RETURN PLUS PROGRAMMED!" is displayed and the registration is completed.

To cancel register a TV channel as the "Return Channel" :

while viewing any TV channel, press the RETURN+ button and hold for more than 3 seconds continuously. "RETURN PLUS CANCELED!" is displayed and the registration is cancelled.

- When you turn off the TV, the registration for the "Return Channel" is cancelled.
- If you want to view the "Return Channel" and another TV channel alternately, first choose a channel other than the "Return Channel". and then press the RETURN+ button to change the channel to the "Return Channel" In this way, you can view two channels alternately by pressing the RETURN+ button.

RETURN function :

The TV temporarily memorises the TV channel that was chosen right before the current TV channel as the "Last Channel". By pressing the RETURN+ button, you can alternately view the current TV channel and the "Last Channel".

- If you want to view two channels alternately by using the RETURN function, first choose one TV channel and then choose the other TV channel with the Number buttons. If you choose the TV channel without using the Number buttons, there are cases where a channel other than the one you first chose is registered as the "Last Channel".

∞ ○ I/II button

When you are viewing a bilingual broadcast programme, you can choose the sound from Bilingual I (Sub I) or Bilingual II (Sub II). When the stereo broadcasting is received poorly, you can change from stereo to mono sound so that you can hear the broadcast more clearly and easily.

Press the ∞ ○ I/II button to choose a sound mode.

∞ : Stereo sound

○ : mono sound

I : Bilingual I (sub I)

II : Bilingual II (sub II)

MONO : Cancels the Multi Sound function, and the sound becomes monaural.

- The sound mode you can choose differs depending on the TV programme.
- This function does not work in the VIDEO modes.

DISPLAY button

You can display the PR LIST, programme number or VIDEO terminal number on the screen.

Press the DISPLAY button.

Press the DISPLAY button changes the display as follows:

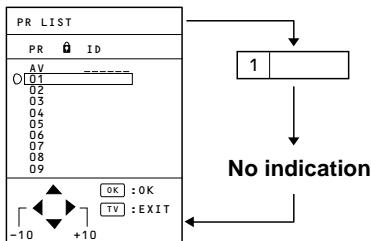

Choose a TV channel or a VIDEO terminal

- 1 Press the DISPLAY button to display the PR LIST.
- 2 Press the ▲/▼ and ◀/▶ buttons to choose a programme number or VIDEO terminal.

Then press the MENU/OK button.

- For programme numbers with the CHANNEL GUARD function set, the  (CHANNEL GUARD) mark is displayed next to the programme number in the PR LIST.
- The VIDEO terminals are registered after the programme number PR99.

COLOUR SYSTEM button

The colour system is chosen automatically. However, if the picture is not clear or no colour appears, choose the colour system manually.

Press the COLOUR SYSTEM button to choose the appropriate colour system.

AUTO :

This function detects a colour system from the input signal.

- The AUTO mode may not function properly if you have poor signal quality. If the picture is abnormal in the AUTO mode, choose another colour system manually.
- The AUTO mode detects a colour system from the input signal and chooses the appropriate colour system automatically.
- When changing the COLOUR SYSTEM of the SUB-picture, see "Change the colour system of the SUB-picture" on page 15 for details.

Remote control buttons and functions

- For the colour systems in each country or region, see the table "BROADCASTING SYSTEMS" on page 12.

SOUND SYSTEM button

The sound system is chosen automatically. However, if you cannot hear the sound normally even when the picture appears normally, choose the sound system manually.

Press the SOUND SYSTEM button to choose the appropriate sound system.

B/G : B/G system

I : I system

D/K : D/K system

M : M system

- This function does not work in the VIDEO mode.
- For the sound systems in each country or region, see the table "BROADCASTING SYSTEMS" on page 12.

BROADCASTING SYSTEMS

For sound system colour system in your country or region, refer to the table below.

COLOUR SYSTEM

Area	Country or Region	System
Asia, Middle East	Bahrain, Kuwait, Oman, Qatar, United Arab Emirates, Yemen, etc. Indonesia, Malaysia, Singapore, Thailand, India, etc.	PAL
	China, Vietnam, etc	PAL
	Hong Kong, etc	PAL
	Islamic Republic of Iran, Lebanon, Saudi Arabia, etc.	SECAM
Europe	Philippines, Taiwan, Myanmar, etc	NTSC
	Russia, etc	SECAM
	Czech Republic, Poland, etc	PAL
	Germany, Holland, Belgium, etc	PAL
Oceania	UK, etc	PAL
	Australia, New Zealand, etc	PAL
Africa	Republic of South Africa, etc	PAL
	Nigeria, etc	PAL
	Egypt, Morocco, etc	SECAM

SOUND SYSTEM

Area	Country or Region	System
Asia, Middle East	Bahrain, Kuwait, Oman, Qatar, United Arab Emirates, Yemen, etc. Indonesia, Malaysia, Singapore, Thailand, India, etc.	B/G
	China, Vietnam, etc	D/K
	Hong Kong, etc	I
	Islamic Republic of Iran, Lebanon, Saudi Arabia, etc.	B/G
Europe	Philippines, Taiwan, Myanmar, etc	M
	Russia, etc	D/K
	Czech Republic, Poland, etc	D/K
	Germany, Holland, Belgium, etc	B/G
Oceania	UK, etc	I
	Australia, New Zealand, etc	B/G
Africa	Republic of South Africa, etc	I
	Nigeria, etc	B/G
	Egypt, Morocco, etc	B/G

FREEZE button

You can view the Main picture's frozen image as the SUB-picture.

Press the FREEZE button.

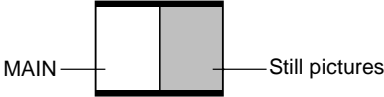

To cancel the FREEZE function :

Press the FREEZE button again.

- You cannot use the FREEZE button when the SUB-picture or the MAIN-picture are displayed on the screen.
- If you press the FREEZE button when receiving the Progressive Video Signal (525P signal), "525P" appears on the screen and the FREEZE function does not operate.

STROBE button

You can view the MAIN-picture as 15 consecutive still images.

Press the STROBE button.

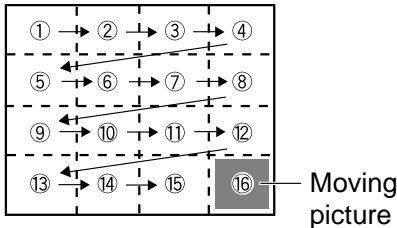

To cancel the STROBE function:

Press the STROBE button to return to the MAIN-picture.

- If signal level of the MAIN-picture is weak, the still images become abnormal.
- You cannot use the STROBE button when the SUB-picture or the MAIN-picture are displayed on the screen.

- If you press the STROBE button when receiving the Progressive Video Signal (525P signal), "525P" appears on the screen and the STROBE function does not operate.
- You cannot change the TINT setting for the still images on the screen even if you are viewing a programme with NTSC colour system.

■ Using the MULTI function

You can display multi-pictures that enable you to easily find a program you want to view.

1 Press the MULTI button.

Press the MULTI button changes the display as follow:

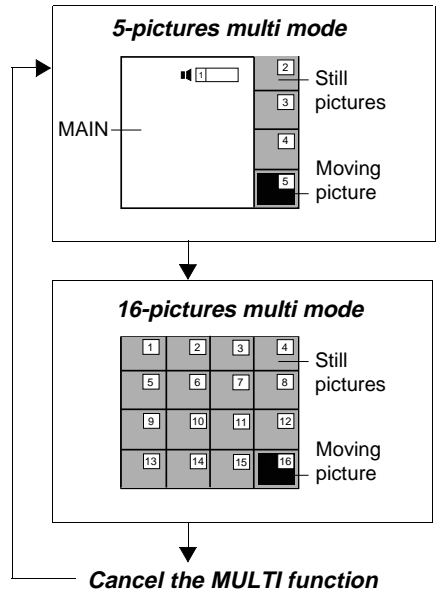

To display next Multi pictures :

Press the NEXT button.

2 Choose the desired picture with the ▲/▼ and ◀/▶ buttons, and then press the MENU/OK button.

The screen switches to the TV channel or VIDEO mode of your choice.

- Any programme numbers to which no TV channel has been registered, or programme numbers to which CHANNEL GUARD has been set is not displayed.
- You cannot perform menu operations such as headphone volume adjustment. Cancel the MULTI function once to perform menu operations.
- If you press the MULTI button when receiving the Progressive Video Signal (525P signal), "525P" appears on the screen and the MULTI function does not operate.
- During the short period that is required for the Multi-pictures display to close no sound comes from the television.

■ Using the PIP function

You can view two pictures (MAIN and SUB) at the same time.

Press the PIP button.

Press the PIP button changes the display as follows:

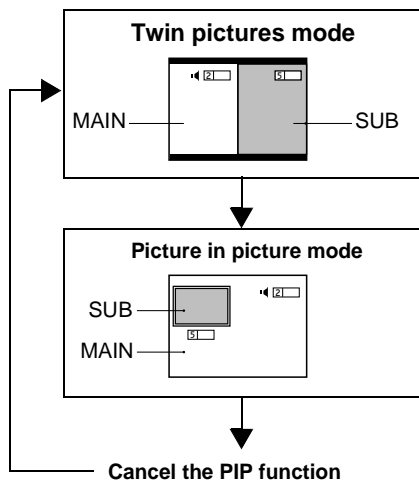

- You cannot view a picture from the same programme number (or the same VIDEO terminal) as both the MAIN-picture and the SUB-picture at the same time.
- If the MAIN-picture signal is poor, then the quality of the SUB-picture may also be poor.
- If the picture standards of both pictures are different, the top and bottom or one of them may be missing.
- The ZOOM function does not operate when viewing pictures using the PIP function.
- The SUB-picture cannot be output from TV.
- If you press the PIP button when receiving the Progressive Video Signal (525P signal), "525P" appears on the screen and the PIP function does not operate.

Choose a TV channel for the SUB-picture

Press the SUB-P +/- button.

Listen to the sound of SUB-picture

You can listen to the sound of SUB-picture on your headphones while listening to the sound of MAIN-picture on the TV speakers. For details, see "HEADPHONE" on page 23.

Change the colour system of the SUB-picture

- 1 While the SUB-picture is displayed, press the MENU/OK button to display the MENU (main manu).
- 2 Press the ▲/▼ and ◀/▶ buttons to choose PICTURE FEATURES, and then press the MENU/OK button.
- 3 Press the ▲/▼ buttons to choose COLOUR SYSTEM, and then press the MENU/OK button.

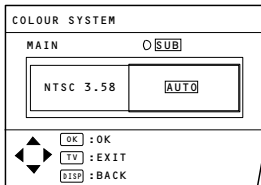

- 4 Press the ◀/▶ buttons to choose SUB, and then press the ▲/▼ buttons to choose the appropriate colour system. Then press the MENU/OK button.

- You cannot change the COLOUR SYSTEM of the SUB-picture using the COLOUR SYSTEM button on the remote control.

POSITION button

You can adjust the position of the SUB-Picture when using the Picture in picture mode.

Press the POSITION button repeatedly.

Each time you press the button, the SUB-Picture moves counterclockwise.

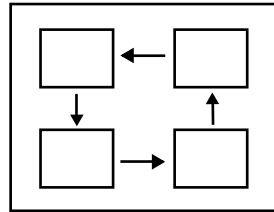

SWAP button

You can replace the MAIN-picture and the SUB-picture with each other.

Press the SWAP button.

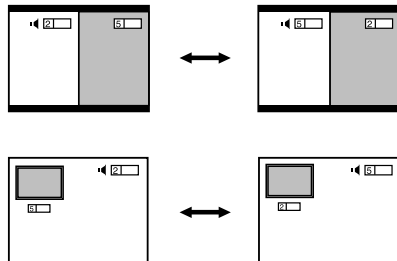

- Do not press the SWAP button while you are recording the TV output on the VCR. If you do, the output signal will change.

Using the TV's menu

This TV has a number of functions you can operate using menus.

To fully utilize all your TV's functions, you need to understand the basic menu operating techniques fully.

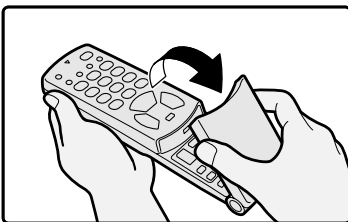
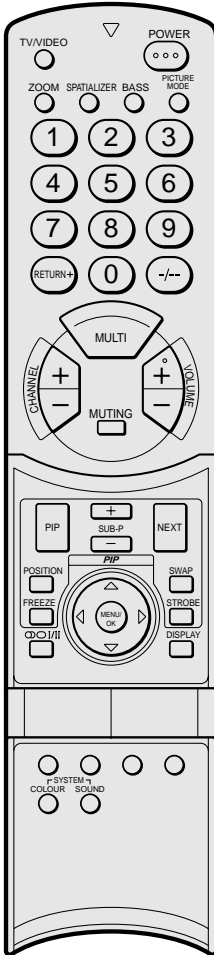

Basic operation

- 1 Press the MENU/OK button to display the MENU (main menu).

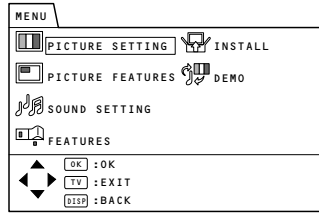

- The display appearing at the bottom of a menu indicates buttons on the remote control you can use when you operate a chosen function.

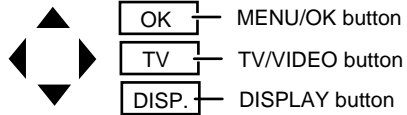

- 2 Press the ▲/▼ and ◀/▶ buttons to choose a menu title, and press the MENU/OK button.

The menu appears.

To return to the previous menu:
Press the DISPLAY button.

To exit a menu instantly:
Press the TV/VIDEO button.

- 3 Press the ▲/▼ buttons to choose a function.

- For details of the functions in the menus, see the following pages.

4 Press the ◀/▶ buttons to choose the setting of that function.

- If you want to operate a function which appears only with its name, follow the descriptions of that function on the following pages.

5 Press the MENU/OK button to complete the setting.

The menu disappears.

- When watching the television with the NTSC system, the menus are displayed at about half of their normal vertical size.

Operation with the buttons on the TV

You can also operate the menus using the buttons on the front panel of the TV.

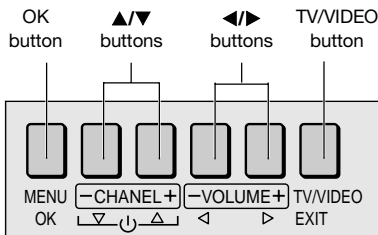

- There is no button on the front panel of the TV that has the function of the DISPLAY or coloured buttons.

PICTURE SETTING menu

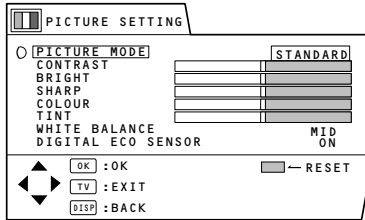

PICTURE MODE

You can choose one of three PICTURE MODEs to adjust the picture settings automatically.

BRIGHT:

Heightens contrast and sharpness.

STANDARD:

Standardizes picture adjustment.

SOFT:

Softens contrast and sharpness.

- You can also operate the PICTURE MODE function with the PICTURE MODE button on the remote control. For details, see "PICTURE MODE button" on page 10.

Adjusting the picture

You can change the picture settings of each picture mode as you like. The picture settings changed are stored in the picture mode.

CONTRAST

You can adjust the picture contrast.

- ◀ : lower
- ▶ : higer

BRIGHT

You can adjust the picture brightness.

- ◀ : darker
- ▶ : brighter

SHARP

You can adjust the picture sharpness.

- ◀ : softer
- ▶ : sharper

- You cannot select the SHARP function when receiving the Progressive Video Signal (525P signal).

COLOUR

You can adjust the picture colour.

- ◀ : lighter
- ▶ : deeper

TINT

You can adjust the picture tint.

- ◀ : reddish
- ▶ : greenish

- You can change the TINT setting (picture tint) only when the colour system is NTSC 3.58 or NTSC 4.43.
- You cannot select the TINT function when receiving the Progressive Video Signal (525P signal).

To return to the default settings in each PICTURE MODE :

Press the blue button. Returns the picture settings in the currently chosen PICTURE MODE mode to the default settings, and stores them in the PICTURE MODE again.

WHITE BALANCE

You can select one of three WHITE BALANCE modes (three tones of white) to adjust the white balance of the picture. Since white is the colour which is used as a reference for all the other colours, changing the WHITE BALANCE mode affects the appearance of all the other colours on the screen.

COOL:

A bluish white. Using this mode when watching bright pictures allows you to enjoy a more vivid and bright picture.

MID:

The normal white colour.

WARM:

A raddish white. Using this mode when watching films allows you to enjoy colours that are characteristic of films.

- You cannot select the WHITE BALANCE function in the Twin pictures mode or the 16:9 mode of the ZOOM function.

■ DIGITAL ECO SENSOR

When you set the DIGITAL ECO SENSOR function to ON, the screen contrast is automatically adjusted to a setting suitable for the brightness of your room. This reduces eye strain for you and the power consumption of the TV.

ON :

This function is turned on.

OFF :

This function is turned off.

DISPLAY :

This function is turned on. Further, clover marks ♣ indicating the brightness of your room are displayed for several seconds each time the brightness changes. The number of clover marks displayed on the screen increases as your room becomes darker.

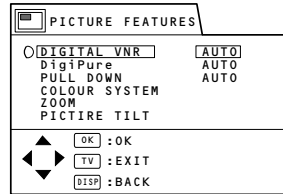
PICTURE FEATURES menu**■ DIGITAL VNR**

The DIGITAL VNR function cuts down the amount of noise in the original picture.

- You cannot select the DIGITAL VNR function when receiving the Progressive Video Signal (525P signal).

AUTO:

The TV will be automatically adjust the level of the DIGITAL VNR effect to match the amount of noise in the picture, giving you the best possible picture.

- If you set the DIGITAL VNR effect too high it can make the picture less sharp. It is recommended to use the AUTO setting if you can.

MAX:

The level of the DIGITAL VNR effect is set to the maximum. If you set the DIGITAL VNR function to AUTO but still notice some noise, change the setting from AUTO to MAX.

- The MAX setting is not suitable for high-quality pictures which contain a lot of noise.

MIN:

The level of the DIGITAL VNR effect is set to the minimum. If you set the DIGITAL VNR function to AUTO but feel that the sharpness of the original picture has not been reproduced fully, change the setting from AUTO to MIN.

- The MIN setting is not suitable for low-quality pictures which contain a lot of noise.

■ DigiPure

The DigiPure function uses the latest in digital technology to give you a natural looking picture. The DigiPure function includes the following two functions.

DigiPure function:

This function helps to create a natural looking picture by eliminating unnecessary edges from high-contrast and crisp images.

Conversely, for images with low-contrast, edges are added to produce a sharper, more detailed picture.

You can choose from the DigiPure function settings of AUTO, MIN and MAX.

Picture motion compensation function:

This function displays fast-moving pictures (for example, the players or ball in a football game) more smoothly and naturally on the screen.

- You cannot select the DigiPure function when receiving the Progressive Video Signal (525P signal).

AUTO:

The TV will automatically adjust the level of the DigiPure effect to match the amount of noise in the picture, giving the best possible picture.

- If you set the DigiPure effect too high on a low-quality picture that contains a lot of noise, this may actually make the noise worse. It is recommended to use the AUTO setting if you can.

MAX:

The level of the DigiPure effect is set to the maximum. If you set the DigiPure function to AUTO but feel that the original picture quality has not been reproduced fully, change the setting from AUTO to MAX.

- The MAX setting is not suitable for low-quality pictures which contain a lot of noise.

MIN:

The level of the DigiPure effect is set to the minimum. When you set the DigiPure function to AUTO and notice some noise, change the setting from AUTO to MIN.

- The MIN setting is not suitable for high-quality pictures which contain very little noise.

OFF:

The DigiPure function is turned off.

■ PULL DOWN

The PULL DOWN function displays a cinema film picture more smoothly and naturally on the screen.

AUTO:

This function is turned on. Normally keep this function set to AUTO.

OFF:

This function is turned off.

- The motion may appear unnatural when viewing images with the NTSC colour system. To make the motion smoother, switch the PULL DOWN function from AUTO to OFF.
- You cannot select this function in the Twin pictures mode or the Picture in picture mode.

■ COLOUR SYSTEM

The colour system is chosen automatically. However, if the picture is not clear or no colour appears, choose the colour system manually.

- 1 Choose **COLOUR SYSTEM**, then press the **MENU/OK** button.

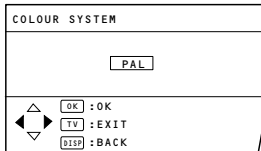

- 2 Press the **◀/▶** buttons to choose the appropriate colour system. Then press the **MENU/OK** button.
 - When changing to the **COLOUR SYSTEM** of the **SUB-picture**, see "Change the colour system of the **SUB-picture**" on page 15 for details.
 - You can also operate the **COLOUR SYSTEM** function with the **COLOUR SYSTEM** button on the remote control. For details, see "COLOUR SYSTEM button" on page 11.

■ ZOOM

You can change the screen size according to the picture aspect ratio. Choose the optimum one of three **ZOOM** modes.

- 1 Choose **ZOOM**, then press the **MENU/OK** button.

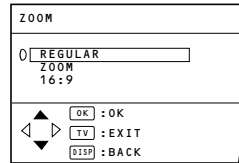

- 2 Press the **▲/▼** buttons to choose a **ZOOM** mode. Then press the **MENU/OK** button.

The picture expands and the chosen **ZOOM** mode is displayed in about 5 seconds.

- You can choose a **ZOOM** mode from **REGULAR**, **ZOOM** or **16:9** modes. For details, see "ZOOM button" on page 9.
- You cannot select the **ZOOM** function when receiving the **Progressive Video Signal (525P signal)**.

■ PICTURE TILT

There are cases where the Earth's magnetic force may make the picture tilt. If this happens, you can correct the picture tilt.

- 1 Choose **PICTURE TILT**, then press the **MENU/OK** button.

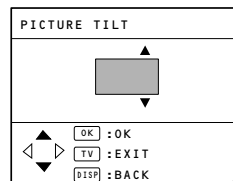

- 2 Press the **▲/▼** buttons until the picture becomes level. Then press the **MENU/OK** button.

SOUND SETTING menu

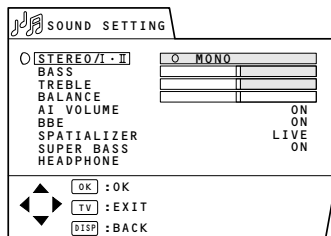

■ STEREO / I·II

When you are viewing a bilingual broadcast programme, you can choose the sound from Bilingual I (sub I) or Bilingual II (sub II). When the stereo broadcasting is received poorly, you can change from stereo to mono sound so that you can hear the broadcast more clearly and easily.

∞ : Stereo sound

○ : mono sound

I : Bilingual I (sub I)

II : Bilingual II (sub II)

MONO: Cancels the Multi Sound function, and the sound becomes monaural.

- The sound mode you can choose differs depending on the TV programme.
- This function does not work in the VIDEO modes.

■ Adjusting the sound

You can adjust the sound to your liking.

BASS

You can adjust the low tone of the sound.

◀ : weaker

▶ : stronger

TREBLE

You can adjust the high tone of the sound.

◀ : weaker

▶ : stronger

BALANCE

You can adjust the volume balance between the left and right speakers.

◀ : turn the left speaker's volume level up.

▶ : turn the right speaker's volume level up.

■ AI VOLUME

You can prevent the sudden increase or decrease of sound that occurs when changing the channel to another channel or switching the VIDEO mode to another VIDEO mode.

ON :

This function is turned on.

OFF :

This function is turned off.

- The AI VOLUME function for TV mode and VIDEO mode can be set separately. For example, you can set it to be OFF in TV mode and ON in VIDEO mode. If you set the AI VOLUME function while viewing images from a VIDEO terminal, the setting is registered as the setting for VIDEO mode.
- The AI VOLUME function may not operate as expected if the sound input level from a broadcast station (or video software) is extremely low.

■ BBE

You can use the BBE function to enjoy easy-to-listen sound that is faithful to the original sound recorded.

ON :

This function is turned on.

OFF :

This function is turned off.

Licensed by BBE Sound, inc. BBE is a registered trademark of BBE Sound, inc.

■ SPATIALIZER

You can enjoy Surround sound with a "live" effect by using the SPATIALIZER function. You can choose one of two SPATIALIZER modes.

- You can choose a SPATIALIZER mode from LIVE, MONO or OFF modes. For details, see " SPATIALIZER button " on page 9.

The SPATIALIZER is manufactured under license from Desper Products, Inc.

■ SUPER BASS

You can enjoy a powerful bass sound by using the Super Bass (Super Bass Reflex) function.

ON :

This function is turned on.

OFF :

This function is turned off.

■ HEADPHONE

This function enables you to output the TV's sound from your headphones.

- Choose HEADPHONE, then press MENU/OK button.

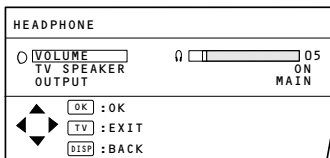

- Use the ▲/▼ button to select, and the ◀/▶ button to set the HEADPHONE function. Then press the MENU/OK button.

VOLUME :

You can adjust the volume of the sound output from your headphones.

TV SPEAKER:

When this function is on, the TV's speaker does not shut off the sound even if headphones are connected.

If you set this function to off, the TV's speaker does not output the sound when the headphones are connected.

OUTPUT:

You can choose the sound from the MAIN-picture(MAIN) or the SUB-picture(SUB) when using the headphones.

- The TV's speaker does not put out the sound from the SUB-picture.
- The sound of the SUB-picture is mono only. You cannot use the STEREO / I • II function for the sound of the SUB-picture.

FEATURES menu

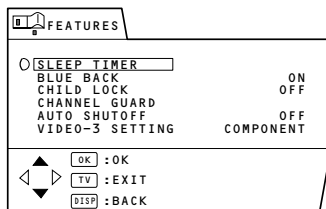

■ SLEEP TIMER

You can set the TV to automatically turn off after a set time.

- 1 Choose SLEEP TIMER, then press the MENU/OK button.

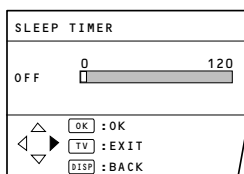

- 2 Press the ◀/▶ buttons to set the period of time.

The TV begins count down from the set time.

- You can set the period of time a maximum of 120 minutes (2 hours) in 10 minute steps.

To cancel this function:

Press the ◀ button to set a period of time to "OFF".

- 3 Press the MENU/OK button to complete the setting.

The menu disappears.

- One minute before this function turns off the TV, "GOOD NIGHT!" appears.
- This function cannot be used to turn off the TV's main power.
- When this function is on, you can display the SLEEP TIMER menu again to confirm or change the remaining time.

■ BLUE BACK

You can set the TV to automatically change to a blue screen and mute the sound if the signal is weak or absent, or when there is no input from an external device.

ON :

This function is turned on.

OFF:

This function is turned off.

■ CHILD LOCK

You can disable the front control buttons of the TV. When this function is set to ON, the TV can be operated only by using the remote control.

Use this function to prevent children from operating the TV at their own discretion (without parent consent).

ON :

This function is turned on.

OFF:

This function is turned off.

■ CHANNEL GUARD

When there is a TV channel you do not want your children to watch, you can lock out the channel. Even when a child chooses a programme number for a locked out channel the screen will change to blue and display  so the channel cannot be viewed.

To set this function

- 1 Choose CHANNEL GUARD, then press the number 0 (AV) button.

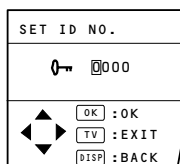

2 Set the ID number you want.

To choose a number:

Press the ▲/▼ buttons.

To move a cursor:

Press the ◀/▶ buttons.

3 Press the MENU/OK button.

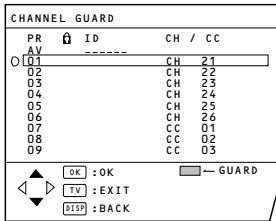

4 Press the ▲/▼ buttons to choose a TV channel.

- The TV shows the TV programme which the chosen TV channel is now broadcasting.

5 Press the blue button to set this function to the TV channel.

🔒 (CHANNEL GUARD) appears and the TV channel is locked.

To cancel this function:

Press the blue button again.

🔒 (CHANNEL GUARD) disappears and the lock is released.

6 Press the MENU/OK button to complete the setting.

The menu disappears.

To view a locked TV channel

1 Choose a programme number in which a TV channel locked with the number buttons or PR LIST.

The screen changes to blue and the 🔒 (CHANNEL GUARD) appears.

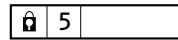

- You cannot choose a locked TV channel with the ▲/▼ buttons.

2 Press the DISPLAY button to display " ID NO. " (ID number input screen).

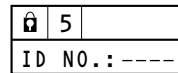

3 Press the number buttons to enter the ID number.

The lock is temporarily released so you can view the TV channel.

If you have forgotten the ID number:

Perform step 1 of "To set this function".

After confirming the ID number, press the TV/VIDEO button to exit the menu.

- When you would like to cancel the CHANNEL GUARD function, you must perform the operation " To set this function" again.

■ **AUTO SHUTOFF**

You can set your TV to turn off if no signal are received for about 15 minutes or longer after the end of a broadcast.

ON :

This function is turned on.

OFF :

This function is turned off.

- The AUTO SHUTOFF function does not turn off the TV's main power.
- The AUTO SHUTOFF will not work for a VIDEO mode.

■ **VIDEO-3 SETTING**

Set the VIDEO-3 SETTING correctly according to the video signal input from the external device connected to the VIDEO-3 terminal. If this setting is incorrect, images will not be displayed.

VIDEO :

If a normal video signal (composite video signal) is input.

COMPONENT :

If a Component video signal (Y/C_B/C_R signals) is input.

- For detailed connecting methods, see " Additional preparation " on page 33.
- This Television is compatible with the Progressive Video Signal (525P signal) only when the component video signal is input.

INSTALL menu

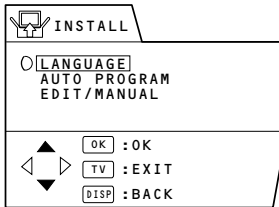

■ LANGUAGE

You can choose the language you want to use for the on-screen display from the language list in a menu.

- 1 Choose LANGUAGE, then press the MENU/OK button.

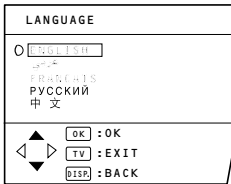

- 2 Press the ▲/▼ buttons to choose a language.
- 3 Press the MENU/OK button to complete the setting.

The menu disappears.

■ AUTO PROGRAM

You can automatically register the TV channels which can be received well at your residence in the TV's programme numbers by performing the following.

- 1 Choose AUTO PROGRAM, then press the MENU/OK button.

The AUTO PROGRAM function starts. The TV channels you receive are automatically stored in the programme numbers list.

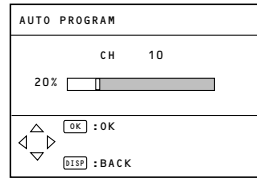

- To cancel the AUTO PROGRAM function, press the DISPLAY button.

- 2 After the TV channels have been stored in the programme number list, the EDIT menu appears.

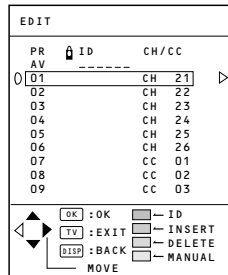

- You can proceed to edit the programme numbers list using the EDIT/MANUAL function. For details, see "EDIT/MANUAL" on page 28.
- If a TV channel you want to view is not stored in the programme numbers list, you can register it using the MANUAL function. For details, see "EDIT/MANUAL" on page 28.
- The AUTO PROGRAM function does not store a TV channel to the programme number 0 (AV).
- If you do not need to use the EDIT/MANUAL function, press the MENU/OK button to exit from the EDIT menu.

■ EDIT/MANUAL

The EDIT/MANUAL functions are divided into two types:

editing of the current programme numbers (EDIT functions) and manual registration of a TV channel you want to view to the programme number (MANUAL function).

CAUTION

- Using the MOVE,DELETE or INSERT function rewrites the current programme numbers list.

Resultingly, the programme number of some of the TV channels will change.

- When a TV channel which has been locked out using the CHANNEL GUARD function, using the MANUAL function for that TV channel cancels the CHANNEL GUARD function.

- When a TV channel has already been registered in PR 99, using the INSERT function deletes the TV channel.

- Choose EDIT/MANUAL, then press the MENU/OK button.

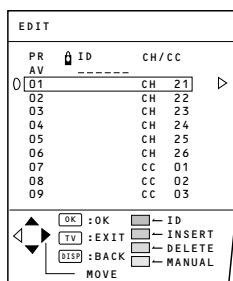

- Follow the operation description of a function you want to use and operate the function.

MOVE :

This function changes a programme number of a TV channel.

ID :

This function registers a Channel name (ID) to a TV channel.

INSERT:

This function adds a new TV channel in the current programme numbers list by using the CH/CC number.

DELETE :

This function deletes a unnecessary TV Channel.

MANUAL :

This function manually registers a new TV channel in a programme number.

- Press the MENU/OK button to complete the setting.

- For programme number PR 0, "AV" appears in the programme numbers list.

FUNCTIONS

MOVE

- Press the ▲/▼ buttons to choose a TV channel.
- Press the ► button to start the MOVE function.

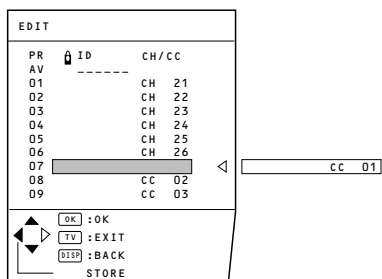

- Press the ▲/▼ buttons to choose a new programme number.

To cancel the MOVE function:
Press the DISPLAY button.

- Press the ◀ button to change the programme number of a TV channel to a new programme number.

ID

- 1 Press the ▲/▼ buttons to choose a TV channel.
- 2 Press the red button to start the ID function.
- 3 Enter a channel name (ID). Press the ▲/▼ buttons to choose a character. press the ◀/▶ buttons to move the cursor.

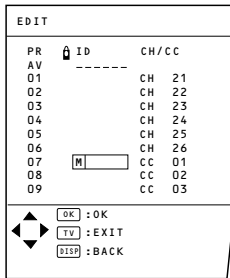

To cancel the ID function:
Press the DISPLAY button.

- 4 Press the MENU/OK button to register a channel name to a TV channel.

DELETE

- 1 Press the ▲/▼ buttons to choose a TV channel.
- 2 Press the yellow button to delete the TV channel.

The TV channel is deleted from the programme numbers list.

MANUAL

- 1 Press the ▲/▼ buttons to choose a programme number to which you want to register a new TV channel.
- 2 Press the blue button to activate the MANUAL function.

At the right side following the CH/CC number, the SYSTEM (sound system) of the TV channel appears.

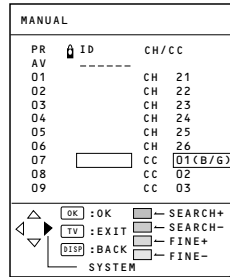

To cancel the MANUAL function:
Press the DISPLAY button.

- 3 Press the ▶ button to choose the system (sound system) for a TV channel you want to register.

- For the sound systems in each country or region, see the table "BROADCASTING SYSTEMS" on page 12.

- 4 Press the green or red button to search for a TV channel.

Scanning stops when the TV finds a TV channel. Then the TV channel is displayed.

- 5 Press the green or red button repeatedly until the TV channel you want appears.

If the TV channel reception is poor:
Press the blue or yellow button to finetune the TV channel.

If you cannot hear the normal sound even when the picture of the TV channel appears normally:

The SYSTEM setting is wrong. Press the ▶ button and choose a SYSTEM that has normal sound.

- 6 Press the MENU/OK button and register the TV channel to a programme number.

The normal EDIT menu is resumed.

INSERT

PREPARATION

- Find the CH/CC number corresponding to the channel number of the TV channel from the on page 31.
- 1 Press the ▲/▼ buttons to choose a programme number for which you will register a new TV channel.
 - 2 Press the green button to start the INSERT function.

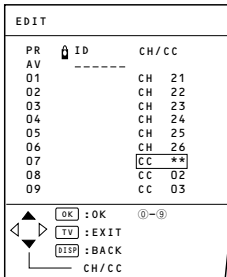

- 3 Press the ▲/▼ buttons to choose "CC" or "CH" according to the CH/CC number of the TV channel.

To cancel the INSERT function:
Press the DISPLAY button.

- 4 Press the Number buttons to enter the remaining CH/CC number.

The TV shifts to registration mode.
When the registration is completed, the picture of the TV channel appears on the screen.

- The CH/CC number is a number indicating the broadcast frequency to the TV. If the TV cannot detect the TV channel corresponding to the broadcast frequency indicated by the CH/CC number, a picture in the no-signal state appears.

CH/CC number

When you want to use the INSERT function on page 30, find the CH/CC number corresponding to the Channel number of the TV channel from this table.

US : The US channel numbers are the channel numbers used in the United States, Philippines, etc.

CCIR: The CCIR channel numbers are the channel numbers used in the Middle East, Southeast Asia ,etc.

OIRT: The OIRT channel numbers are the channel numbers used in Eastern Europe,Russia, Vietnam, etc.

CHINA: The CHINA channel numbers are the channel numbers used in china, etc.

AUSTRALIA: The AUSTRALIA channel numbers are the channel numbers used in Australia, etc.

CC	US	CCIR	Channel		
			OIRT	CHINA	AUSTRALIA
CH 02	US-2	E2	R1	DS-1	AU-0
CH 03	US-3	E3		DS-2	AU-1
CH 04	US-4	E4	R2	DS-3	AU-2
CH 05	US-5	E5	R6	DS-7	AU-6
CH 06	US-6	E6	R7	DS-8	AU-7
CH 07	US-7	E7	R8	DS-9	AU-8
CH 08	US-8	E8	R9		AU-9
CH 09	US-9	E9		DS-10	
CH 10	US-10	E10	R10	DS-11	AU-10
CH 11	US-11	E11	R11	DS-12	AU-11
CH 12	US-12	E12	R12	Z-8	
CH 13	US-13				
CH 14	US-14				
CH 15	US-15				
CH 16	US-16				
CH 17	US-17				
CH 18	US-18				
CH 19	US-19				
CH 20	US-20				
CH 21	US-21	E21		DS-13	
CH 22	US-22	E22		DS-14	
CH 23	US-23	E23		DS-15	
CH 24	US-24	E24		DS-16	
CH 25	US-25	E25		DS-17	
CH 26	US-26	E26		DS-18	
CH 27	US-27	E27		DS-19	
CH 28	US-28	E28		DS-20	
CH 29	US-29	E29		DS-21	
CH 30	US-30	E30		DS-22	
CH 31	US-31	E31		DS-23	
CH 32	US-32	E32		DS-24	
CH 33	US-33	E33			
CH 34	US-34	E34			
CH 35	US-35	E35			
CH 36	US-36	E36			
CH 37	US-37	E37			
CH 38	US-38	E38		DS-25	
CH 39	US-39	E39		DS-26	
CH 40	US-40	E40		DS-27	
CH 41	US-41	E41		DS-28	
CH 42	US-42	E42		DS-29	
CH 43	US-43	E43		DS-30	
CH 44	US-44	E44		DS-31	
CH 45	US-45	E45		DS-32	
CH 46	US-46	E46		DS-33	
CH 47	US-47	E47		DS-34	
CH 48	US-48	E48		DS-35	
CH 49	US-49	E49		DS-36	
CH 50	US-50	E50		DS-37	
CH 51	US-51	E51		DS-38	
CH 52	US-52	E52		DS-39	
CH 53	US-53	E53		DS-40	
CH 54	US-54	E54		DS-41	
CH 55	US-55	E55		DS-42	
CH 56	US-56	E56		DS-43	
CH 57	US-57	E57		DS-44	
CH 58	US-58	E58		DS-45	
CH 59	US-59	E59		DS-46	
CH 60	US-60	E60		DS-47	
CH 61	US-61	E61		DS-48	
CH 62	US-62	E62		DS-49	
CH 63	US-63	E63		DS-50	
CH 64	US-64	E64		DS-51	
CH 65	US-65	E65		DS-52	
CH 66	US-66	E66		DS-53	
CH 67	US-67	E67		DS-54	
CH 68	US-68	E68		DS-55	
CH 69	US-69	E69		DS-56	
CH 70				DS-57	

CC	US	CCIR	Channel		
			OIRT	CHINA	AUSTRALIA
CC 01		S-1			AU-5
CC 02		S-2		Z-1	
CC 03		S-3		Z-2	
CC 04		S-4		Z-3	
CC 05		S-5		Z-4	
CC 06		S-6			AU-5A
CC 07		S-7		Z-5	
CC 08		S-8		Z-6	
CC 09		S-9		Z-7	
CC 10		S-10		DS-6	
CC 11		S-11		Z-9	
CC 12		S-12		Z-10	
CC 13		S-13		Z-11	
CC 14	A	S-14			
CC 15	B	S-15		Z-12	
CC 16	C	S-16		Z-13	
CC 17	D	S-17		Z-14	
CC 18	E	S-18		Z-15	
CC 19	F	S-19		Z-16	
CC 20	G	S-20		Z-17	
CC 21	H	S-21		Z-18	
CC 22	I	S-22		Z-19	
CC 23	J	S-23		Z-20	
CC 24	K	S-24		Z-21	
CC 25	L	S-25		Z-22	
CC 26	M	S-26		Z-23	
CC 27	N	S-27		Z-24	
CC 28	O	S-28		Z-25	
CC 29	P	S-29		Z-26	
CC 30	Q	S-30		Z-27	
CC 31	R	S-31		Z-28	
CC 32	S	S-32		Z-29	
CC 33	T	S-33		Z-30	
CC 34	U	S-34		Z-31	
CC 35	V	S-35		Z-32	
CC 36	W	S-36		Z-33	
CC 37	W+1	S-37		Z-34	
CC 38	W+2	S-38		Z-35	
CC 39	W+3	S-39		Z-36	
CC 40	W+4	S-40		Z-37	
CC 41	W+5	S-41			
CC 42	W+6				
CC 43	W+7				
CC 44	W+8				
CC 45	W+9				
CC 46	W+10				
CC 47	W+11				
CC 48	W+12				
CC 49	W+13				
CC 50	W+14				
CC 51	W+15				
CC 52	W+16				
CC 53	W+17				
CC 54	W+18				
CC 55	W+19				
CC 56	W+20				
CC 57	W+21				
CC 58	W+22				
CC 59	W+23				
CC 60	W+24				
CC 61	W+25				
CC 62	W+26				
CC 63	W+27				
CC 64	W+28				
CC 75		X			
CC 76		Y	R3	DS-4	
CC 77		Z	R4	DS-5	AU-3
CC 78		Z+1	R5		
CC 79		Z+2			AU-4
CC 95	A-5				
CC 96	A-4				
CC 97	A-3				
CC 98	A-2				
CC 99	A-1				

DEMO menu

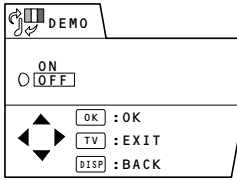

The DEMO function automatically demonstrates some of the TV function.

When the DEMO function is set to ON:

Each time the TV is turned on, the demonstration starts automatically.

If you do not want that to happen, set the DEMO function to OFF.

- 1 Press the ▲/▼ buttons to choose ON.

To cancel the DEMO function, choose off.

- 2 Press the MENU/OK button to complete the settings.

The DEMO function is set to ON, and the demonstration will start.

To stop the demonstration:

Press one of the buttons on the remote control.

Additional preparation

■ Connecting the external devices

Connect the devices to the TV, paying attention to the following connection diagram.

Before connecting anything:

- Read the manuals provided with the devices. Depending on the devices, the connection method may differ from the figure. In addition, the device settings may be changed depending on the connection method to secure proper operation.
- Turn off all the devices including the TV.
- The "Specifications" on page 40 contains the details of the VIDEO terminals. If you are connecting a device not listed in the following connection diagram, see the "Specifications" to choose the best VIDEO terminal.
- Note that connecting cables are not supplied.
- When connecting devices that are supported by AV COMPU LINK, see "Connecting AV COMPU LINK Supported Devices" on page 35.

- ① VCR (composite signal)
- ② VCR (S-VIDEO signal; Y/C)
- ③ VCR for recording (composite signal)
- ④ DVD player (composite signal)
- ⑤ DVD player (S-VIDEO signal; Y/C)
- ⑥ DVD player (component video signals; Y/C_B/C_R)
- ⑦ TV game (composite signal)
- ⑧ TV game (S-VIDEO signal; Y/C)
- ⑨ Camcorder (composite signal)
- ⑩ Camcorder (S-VIDEO signal; Y/C)
- ⑪ Headphones

Ⓐ AV COMPU LINK cable

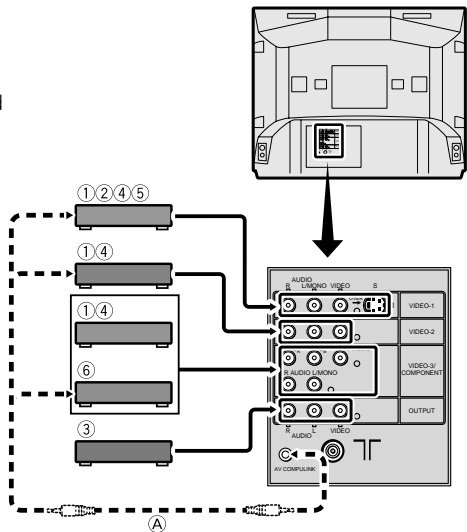
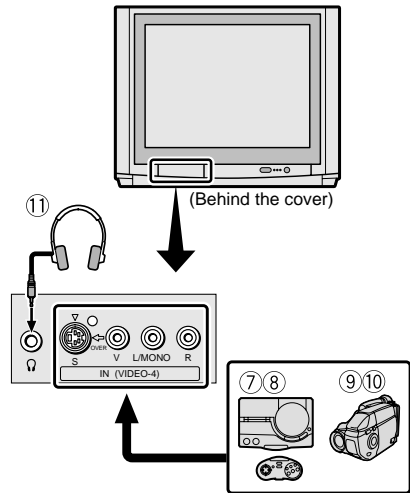

Connecting methods

- 1 Connect the TV's VIDEO jack and the device's VIDEO OUT (video output) jack with a video cable.

If connecting a device to the TV with an S-VIDEO cable :

Connect the VCR's S-VIDEO OUT (S-VIDEO output) connector and the TV's "S" (S-VIDEO) connector with an S-VIDEO cable, instead of connecting with a video cable.

Note that the connection with a video cable will be ignored in case you connect a VCR to the TV with both video cable and S-VIDEO cable.

If connecting a DVD player to the TV with a component video cable :

Connect three jacks (Y/VIDEO, C_B and C_R) in the VIDEO-3 terminal and the DVD player's COMPONENT (component video output) jacks with a component video cables, instead of connection with a video cable. Then set the VIDEO-3 SETTING to COMPONENT, according to "VIDEO-3 SETTING" on page 26.

- This Television is compatible with the Progressive video signal (525P signal). (When the component video signal is input.)

If you have a DVD player that outputs Progressive video signals (525P) as a component video signal, then by attaching the device to the television with a component video cable you can see the actual images that are recorded on a DVD disc as an original image source.

If connecting a device to the VIDEO-3/COMPONENT terminal with a video cable :

Connect the TV's Y/VIDEO jack and the device's VIDEO OUT (video output) jack with a video cables.

Then set the VIDEO-3 SETTING to VIDEO according to "VIDEO-3 SETTING" on page 26.

- In the VIDEO-4 terminal, the VIDEO jack is indicated by "V".
- 2 Connect the TV's AUDIO jacks (L/MONO and R) and the device's AUDIO OUT (audio L/R output) jacks with an audio cable.

If the device's sound output is in mono :

Connect the device's AUDIO OUT jack and the TV's L/MONO jack with an audio cable.

Connecting devices to the OUTPUT terminal

The signals of the images and sound you are currently viewing with this TV are output through the OUTPUT terminal. By connecting a VCR to the OUTPUT terminal, you can record the currently shown image and sound to that VCR. To do this, connect the VCR and OUTPUT terminal following the steps below.

- 1 Connect the VIDEO jack in the OUTPUT terminal and the VCR's VIDEO IN (video input) jack with a video cable.
- 2 Connect the AUDIO jacks (L and R) in the OUTPUT terminal and the VCR's AUDIO IN (audio L/R input) jacks with an audio cable.

- When you turn off the TV, the signals from the OUTPUT terminal are also turned off.
- The component signals input from the VIDEO-3/COMPONENT terminal cannot be output through the OUTPUT terminal.

Connecting Headphones

Connect the headphones with a stereo mini jack (of 3.5 mm in diameter) to the Headphone jack at the TV front panel.

■ Connecting AV COMPU LINK Supported Devices

AV COMPU LINK remote control system is a system in which related devices are automatically controlled when you operate one device.

If you apply this system to the TV, you can have the TV automatically perform the required operations by operating one external device. You don't have to use the TV's remote control to turn on the TV or change the VIDEO modes.

Examples of the AV COMPU LINK remote control system operations

Simply by pressing the PLAY button on a VCR or a DVD player, you can view images from the device.

Simply by inserting a pre-recorded tape (a tape with the record safety tab removed) to a VCR, you can view the tape.

Simply by operating the AV Control Receiver, you can have the TV turned on/off (in standby mode) or the VIDEO mode changed correctly.

- The performance of the AV COMPU LINK remote control system varies depending on the connected device. See the device's instruction manual.
- When you select "TV SOUND" as the input source with the AV Control Receiver, there are cases where the TV's MUTING function automatically operates and the sound from the TV's speakers is muted.
In such cases, press the VOLUME-/+ buttons or the MUTING button on the TV's remote control to cancel the MUTING function. You can regain the sound from the TV's speakers.

Conditions to use the AV COMPU LINK remote control system

- A device equipped with an AV COMPU LINK terminal is required.
- You must connect the TV and the device with an AV COMPU LINK cable.
AV COMPU LINK cable is not supplied with this TV. If an AV COMPU LINK cable is unavailable, connect them with a cable with dia. 3.5 mm (mono) male plugs at both ends.
- You must connect the device to an appropriate VIDEO terminal and set it up correctly. Otherwise the AV COMPU LINK remote control system will not function correctly. For details, see "Setting up the AV COMPU LINK remote control system".
- The TV must be in standby mode (the POWER lamp lighting red). If the TV's Main power is off (the POWER lamp off), the AV COMPU LINK remote control system does not function.

Setting up the AV COMPU LINK remote control system

CAUTION:

- With some devices, the setup method differs from the ones explained here. Be sure to read the device's instruction manual thoroughly before setting it up.

1 Connect the device to the TV's VIDEO-1 or VIDEO-2 terminal.

If you want to connect a DVD player to the TV with a component video cable :

Connect the DVD player to the TV's VIDEO-3 terminal.

- For detailed connecting instructions, see "Connecting the external devices" on page 33.

Additional Preparation

- 2 Connect the TV's AV COMPU LINK terminal and the device's AV COMPU LINK terminal with an AV COMPU LINK cable.
- 3 Change the device's setting according to the VIDEO terminal it is connected to.

If a VCR is connected to the VIDEO-1 terminal :

Set the VCR's remote control code to A code.

If a DVD player is connected to the VIDEO-1 terminal:

Set the DVD player's AV COMPULINK MODE to DVD2.

If a VCR is connected to the VIDEO-2 terminal:

Set the VCR's remote control code to B code.

If a DVD player is connected to the VIDEO-2 terminal:

Set the DVD player's AV COMPULINK MODE to DVD3.

If a DVD player is connected to the VIDEO-3 terminal with a component video cable:

Set the DVD player's AV COMPULINK MODE to DVD1.

- For instructions on how to change the device's setting, refer to the device's instruction manual.
- If the device you are connecting has neither the remote control code nor the AV COMPULINK MODE, then connect it to the TV's VIDEO-1 terminal.

Troubleshooting

If a problem arises while you are using the TV, please read this "Troubleshooting" well before you request having the TV repaired. You may be able to fix it easily by yourself. For example, if the AC plug is disconnected from the AC outlet, or the TV aerial has problems, you may think there is a problem with the TV itself.

Important:

- This Troubleshooting guide only covers problems whose cause are not easy to determine. If a question arise when you are operating a function, read the page(s) corresponding to the operation of the function well, not this Troubleshooting guide.
- After you have followed the Troubleshooting description or the operating description of the functions concerned without any success, remove the AC plug from the AC outlet and request a repair of your TV. Do not attempt to repair the TV by yourself or remove the rearcover of the TV.

■ If you cannot turn on the TV

- Is the AC plug connected to the AC outlet?
- Is the POWER lamp lit? If not, press the Main power button.

■ No picture/No sound

- Have you chosen a TV channel whose reception is extremely bad? In this case, the BLUE BACK function will be activated, the entire screen becomes blue, and the sound is muted. In spite of this, if you want to view the TV channel, follow the description "BLUE BACK" on page 24 to try to change the BLUE BACK function setting to OFF.
- Are your SOUND SYSTEM settings for the TV channels correct?
Follow the description "SOUND SYSTEM Button" on page 12 to try to solve the trouble.

■ Poor picture

- If noise totally obscures the picture (snow), the aerial or aerial cable may have trouble. Check the following to try to solve the trouble :

Has the TV and aerial been connected properly?

Has the aerial cable been damaged?
Is the aerial pointed to the right direction?

Is the aerial itself faulty?

- If the TV or aerial receives interference from the other devices, stripes or noise may appear in the picture. Move such device as an amplifier, personal computer, or a hair drier that can cause interference away from your TV, or try changing its location. If the aerial suffers interference from a radio tower or high-voltage wire, please contact your local dealer.
- If the TV receives interferences from signal reflecting from mountains or building, double-pictures(ghosting) will occur.
Try to change the aerial's direction or replace the antenna with the one with better directionality.

Troubleshooting

- Are your COLOUR SYSTEM settings for the TV channels correct? Follow the description "COLOUR SYSTEM button" on page 11 to try to solve the trouble.
- Has COLOUR or BRIGHT been controlled properly? Follow the description "Adjusting the picture" on page 18 to try to adjust them properly.
- When a white and bright still image (such as a white dress) is displayed on the screen, the white part may look as if it were coloured.
It is a phenomenon unavoidable due to the nature of the picture tube itself, and not due to a TV failure.
When the picture disappears from the screen, the unnatural colours will also disappear.
- When viewing images from commercially available video software products, or videos from videotapes which have been recored improperly, the top of the image may be distorted.
This is due to the condition of the video signal, and not because of malfunction.
- Have you attempted to use the remote control at the sides or rear of the TV or at a location more than seven meters apart from the TV location? Operate the remote control in the front of your TV or a location less than seven meters from your TV to try to solve the problem.
- Is the CHILD LOCK function set to ON? If the CHILD LOCK function is set to ON, you cannot operate the TV with the front control buttons of the TV. Follow the description "CHILD LOCK" on page 24 to try to set the CHILD LOCK function to OFF.
- If the TV operation becomes disabled suddenly, press the Main power button on the TV and turn off the main power. Try to press the Main power button again to turn on the main power. If the TV returns to a normal state, it is not a failure.
- The following functions do not operate when receiving Progressive Video Signal (525P signal);
Remote control function:
ZOOM, PIP, MULTI, FREEZE and STROBE BUTTON
MENU function:
SHARP, TINT, DIGITAL VNR, Digipure and ZOOM

■ Poor sound

- Have you adjusted BASS or TREBLE properly? If not, follow the description "Adjusting the Sound" on page 22 to try to adjust them properly.
- When the TV channel reception is poor, it can be hard to hear the stereo or bilingual sound. In this case, follow the description "STEREO / I • II" on page 22 to hear the sound more easily by changing it to a mono sound.

■ Operation disabled

- Have the batteries of the remote control become exhausted?
Follow the description "Putting the Batteries into the Remote Control" on page 4 and replace them with new batteries to try solve the problem.

■ Other concerns

- When the SLEEP TIMER function or AUTO SHUTOFF function operates, the TV is automatically turned off.
If the TV is turned off suddenly, try to press the POWER button to turn on the TV once again. At this time, if the TV resumes a normal state, there is no problem.
- If you do not want sound emitted from the TV's speakers when using headphones, change the TV SPEAKER setting in the HEADPHONE menu to OFF. For details, see "HEADPHONE" on page 23.
- If you bring a magnetised device such as a speaker near to your TV, a picture may be warped or unnatural colours appear at the corners of the screen. In this case, keep the device apart from your TV. If the speaker causes such phenomena, use the magnetic-shielded speaker instead.
- A picture may be tilted due to the influence of the earth's magnetism. In this case, use the "PICTURE TILT" on page 21 to complete the tilt.
- It takes a short period of time from the time an operation such as changing channels is performed until an image is displayed. This is not a malfunction. This is the time required for the image to stabilize before it can be displayed.
- The TV may emit a crackling sound due to a sudden change in temperature. It does not matter if a picture or sound does not show any abnormality. If you hear crackling sounds frequently while you are viewing the TV, other causes may be assumed.
For precautionary purposes, request your service technician to inspect it.

- Touching the screen may cause you feel a slight electric shock due to its static electricity.
It is an unavoidable phenomenon due to the construction of the picture tube. It is not a problem with the TV.
You can rest assured that this static discharge does not have harmful influence over the human body.

Specifications

Broadcasting systems	B, G, I, D, K, K1, M
Colour systems	PAL, SECAM, NTSC3.58/4.43MHz
Channels and frequencies	VHF low channel (VL) =46.25 to 168.25 MHz VHF high channel (VH) =175.25 to 463.25 MHz UHF channel (U) =471.25 to 863.25 MHz ■ Receives cable channels in mid band (X to Z+2, S1 to S10), super band (S11 to S20) and hyper band (S21 to S41).
Sound-multiplex systems	A2 (B/G), NICAM (B/G, I, D/K) system
Power requirements	AC 110 to 240V, 50/60Hz
Audio output	Rated Power output: 20W + 20W
VIDEO-1 terminal	RCA connector X 3, S-VIDEO connector X 1 • Video input, S-VIDEO (Y/C) input and Audio L/R inputs are available.
VIDEO-2 terminal	RCA connector X 3 • Video input and Audio L/R inputs are available.
VIDEO-3/COMPONENT terminal	RCA connector X 5 • Video input/Component video (Y/C _B /C _R) input and Audio L/R inputs are available. • Progressive video signal(525P signal) input is available.
VIDEO-4 terminal	RCA connector X 3, S-VIDEO connector X 1 • Video input, S-VIDEO (Y/C) input and Audio L/R inputs are available.
OUTPUT terminal	RCA connector X 3 • Video output and Audio L/R outputs are available.
Headphone jack	Stereo mini-jack (3.5 mm in diameter)
Accessories	Remote control unit X 1 (RM-C215) AA/R6 dry cell battery X 2
Speakers	HV-34LPZ : 12cm round X 2, 3.5cm round X 2 HV-29LPZ : 10cm round X 2, 3.5cm round X 2
Power consumption	HV-34LPZ : Maximum 255W Average 170W HV-29LPZ : Maximum 254W Average 170W
Screen size (measured diagonally)	HV-34LPZ : Picture tube 87cm Visible area 80cm HV-29LPZ : Picture tube 73cm Visible area 68cm
Dimensions(W X H X D)	HV-34LPZ : 898mm X 728mm X 579mm HV-29LPZ : 732mm X 588mm X 518mm
Weight	HV-34LPZ : 75kg HV-29LPZ : 48kg

Design and specifications subject to change without notice.

Pictures displayed on the screen using this TV's ZOOM functions should not be shown for any commercial or demonstration purpose in public places (cafes,hotels, etc.) without the consent of the owners of copyright of the original picture sources, as this constitutes an infringement of copyright.

JVC



彩色電視機

HV-34LPZ HV-29LPZ

Interí Art
Premiere

DigiPure

100Hz & PROGRESSIVE SCAN

目 錄

安裝電視機	3
電視機按鈕和功能	6
遙控器按鈕和功能	8
使用電視機菜單	16
基本操作	16
畫面設定菜單	18
畫面特征菜單	19
聲音設定菜單	22
便利功能菜單	24
導入菜單	27
演示菜單	32
附加準備	33
故障排除	37
技術規格	40

使用說明書



非常感謝您惠購此JVC牌彩色電視機。
請在使用前熟讀此使用說明書，以掌握新電視機的使用方法。

警告：

為了防止發生火災或觸電的危險，請勿將本機曝露於雨中或受潮。

注意：

為了保證人身安全，請遵守下列有關使用本機的注意事項。

- 1 僅在電視機背面所示的電源範圍內使用。
- 2 防止損壞電源線和插頭。從電視機上拔下插頭時，請抓住插頭，勿拉電源線。
- 3 切勿堵塞或遮蓋通風口。
切勿將本機放置在通風不良之處。
安裝電視機時，在電視機周圍應留有大於圖示的最小距離的空間，以便通風。

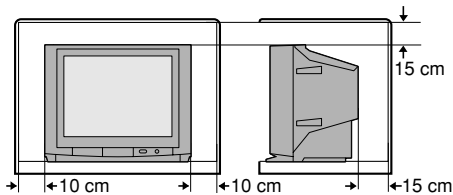

- 4 請勿讓物體或液體進入本機的縫隙內。
- 5 本機發生故障時，請拔下插頭，讓維修服務人員修理。
請勿自行維修或拆下後蓋。
- 6 電視屏幕的表面易於損壞。操作電視機時請多加小心。如果電視屏幕弄髒時，請用乾的軟布擦拭。切勿用力摩擦。切勿使用任何清潔劑或去垢劑。
- 7 長期不使用電視機時，請務必將電源插頭從交流電源插座上撥下。

安裝電視機

注意

- 連接前，請關閉包括本機在內的所有設備。

1 連接天線和錄像機

- 未附帶天線。請使用優質的75歐姆同軸線。
- 連接前，請閱讀錄像機的使用說明書。

如果不連接VCR(錄像機)時(參照圖A):
請將天線與電視機的天線插座連接。

如果連接VCR時(參照圖B):

- 1 將天線與VCR的天線輸入插座連接，
並用另一根天線連接VCR和電視機。
- 2 用視頻電纜將VCR的VIDEO OUT
(視頻輸出)插口和電視機的VIDEO
(視頻)插口連接起來。

用S-VIDEO (超級-視頻) 電纜連接VCR和電視
機時：

用S-VIDEO電纜(A)來代替視頻電纜，將VCR的
S-VIDEO OUT (超級-視頻輸出) 接口與電視機
的S接口連接起來。

- 3 用音頻電纜將VCR的VIDEO OUT
(音頻L/R輸出) 插口和電視機的
AUDIO (音頻) 插口 (L/MONO和
R) 連接起來。

- 如果VCR的音頻輸出為單聲道時，請用音頻
電纜將VCR的AUDIO OUT (音頻輸出) 插口
和電視機的AUDIO L/MONO插口連接起來。
- 如果VCR帶有AV COMPU LINK端子，則可
使用AV COMPU LINK功能。詳細說明，請
參閱第35頁上的“連接支持AV COMPU
LINK的裝置”。

圖A

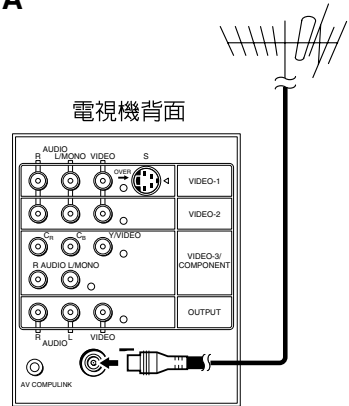

圖B

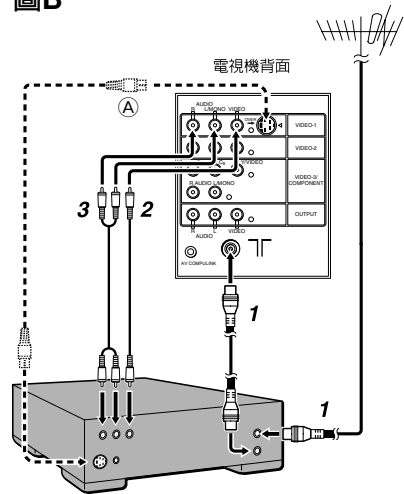

2 連接電源線

將插頭插入交流電源插座。

3 將電池裝入遙控器

請使用兩節AA/R6/5號電池。

從負極裝入電池，請勿搞錯正極和負極。

- 請遵守印刷在電池上的警告事項。
- 如果遙控器工作不正常，請更換電池。
- 附帶的電池僅供安裝和測試電視機之用，請盡快換上新電池。

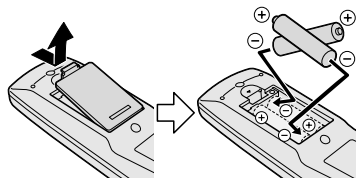

4 初始設定

首次打開電視機時，將進入初始設定模式，顯示JVC標記。

1 按下電視機上的主電源按鈕。

打開電視機，顯示JVC標記。

- 如果電視機上的電源指示燈保持紅色而不變成綠色，則說明電視機處在待機狀態。請按下遙控器上的POWER按鈕來打開電視機。
- 如果不出現JVC標記，則說明電視機已被打開過。此時，請利用“語言”和“自動程序”功能進行初始設定。詳細說明，請參閱第27頁上的“導入菜單”。

2 按下MENU/OK按鈕。

出現語言菜單。可選擇用於在屏幕上顯示的語言。

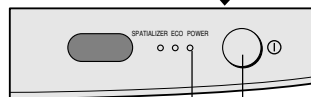
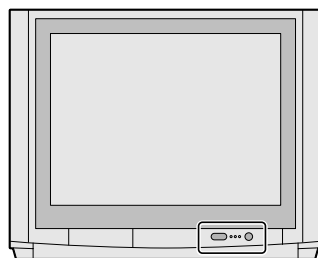

POWER指示燈

主電源按鈕

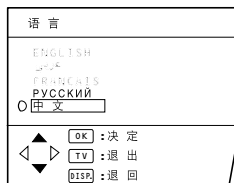

3 按下 ▲/▼ 按鈕，選擇中文。然後按下 MENU/OK 按鈕。

自動程序功能啓動。

接收到的電視頻道被自動登錄在節目號碼一覽內。

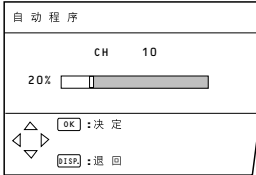

- 要取消自動程序功能時，請按下 DISPLAY 按鈕。

4 電視頻道被登錄在節目號碼（编排）一覽內後，出現编辑菜單。

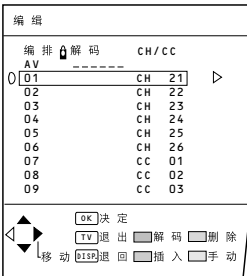

- 可利用編輯/手動功能編輯節目號碼一覽。詳細說明，請參閱第28頁上的“編輯/手動”。
- 如果想觀看的電視頻道未被存儲在節目號碼一覽內，請利用手動功能將其登錄。詳細說明請參閱第28頁上的“編輯/手動”。
- 自動程序功能不會將電視頻道存儲在節目號碼 0 (AV) 內。
- 如果無需使用編輯/手動功能時，請按下 MENU/OK 按鈕，關閉編輯菜單。

安裝結束，請欣賞新的 JVC 電視機。

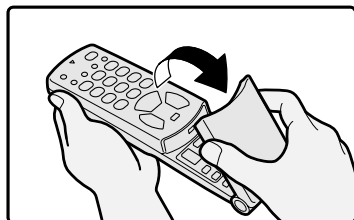
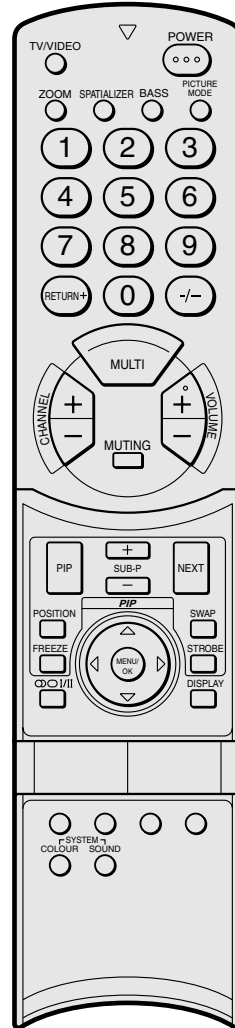

電視機按鈕和功能

打開主電源

按下主電源按鈕 ①。

POWER指示燈 ② 亮紅燈，電視機變為待機模式。

關閉主電源：

再次按下主電源按鈕。

POWER指示燈 ② 熄滅。

從待機模式打開電視機

按下CHANNEL -/+ 按鈕 ⑤。

POWER指示燈 ② 從紅色變為綠色，電視機被打開。

- 在待機模式時，按下TV/VIDEO按鈕 ③ 也可打開電視機。

選擇電視頻道

按下CHANNEL -/+ 按鈕 ⑤。

選擇視頻端子

按下TV/VIDEO按鈕 ③ 或CHANNEL -/+ 按鈕 ⑤。

調節音量

按下VOLUME -/+ 按鈕 ④。

出現音量水準指示器。

MENU按鈕 ⑥

按下可打開菜單。

詳細說明，請參閱第17頁上的“用電視機上的按鈕進行操作”。

遙控器電子眼和ECO電子眼 ⑨

ECO指示燈 ⑦

如果將數字ECO電子眼功能設為開或顯示，則ECO指示燈將亮燈。

SPATIALIZER指示燈 ⑧

如果將环绕控制鍵功能設為單声道或現場，則SPATIALIZER指示燈將亮燈。

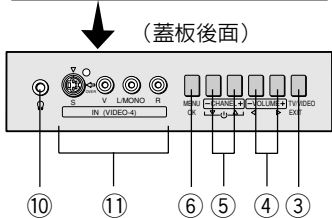
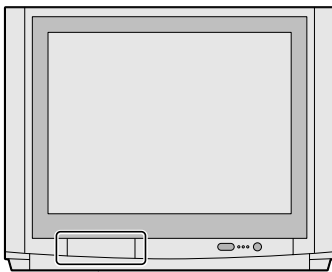
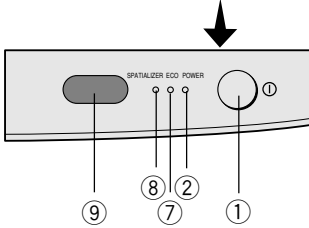
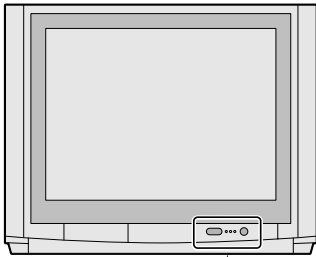

耳機插口 ⑩

將耳機與立體聲微型插口（直徑3.5mm）相連。

使用耳機時，請按照第23頁上的“耳机”的步驟操作。

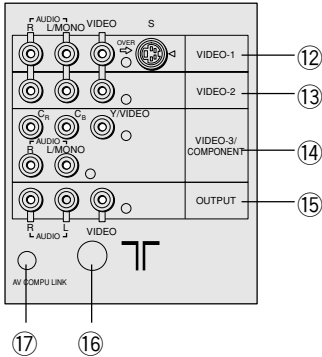
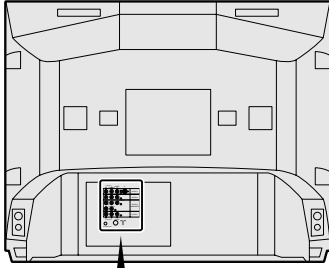

VIDEO-1端子 ⑫

- 請參閱第3頁和第33頁。

VIDEO-2端子 ⑬

- 請參閱第33頁。

VIDEO-3/COMPONENT 端子 ⑭

- 請參閱第26頁和第33頁。

VIDEO-4端子 ⑪

- 請參閱第33頁。

OUTPUT端子 ⑮

- 請參閱第33頁。

天線插座 ⑯

連接天線。

- 請參閱第3頁。

AV COMPU LINK端子 ⑰

- 請參閱第33頁和第35頁。

遙控器按鈕和功能

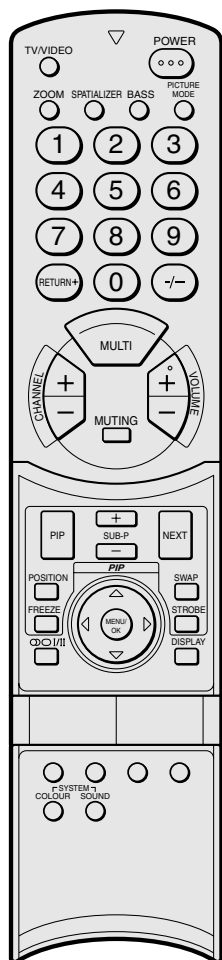

從待機模式打開電視機

按下POWER按鈕。

POWER指示燈從紅色變為綠色，電視機被打開。

- 按下TV/VIDEO按鈕、CHANNEL +/- 按鈕或數字按鈕也可從待機模式打開電視機。

關閉電視機：

再次按下POWER按鈕。

POWER指示燈從綠色變為紅色，電視機進入待機模式。

選擇電視頻道

選擇已設定電視頻道的節目號碼。

按下CHANNEL +/- 按鈕或用數字按鈕輸入節目號碼（编排）。

- 如要將兩位數輸入電視機，請按下-/-按鈕，改為兩位數輸入系統。
- 可從编排一覽中選擇頻道。詳細說明，請參閱第11頁上的“DISPLAY（顯示）”按鈕。
- 如果畫面不清晰或無色彩時，請按照第11頁上的“COLOUR SYSTEM（彩色制式）”的步驟操作。
- 如果即使正常顯示圖像，也不能正常聽見聲音時，請按照第12頁上的“SOUND SYSTEM（聲音制式）”的步驟操作。

調節音量

按下VOLUME +/- 按鈕。

- 不可調節耳機的音量。請按照第23頁上的“耳机”的操作步驟操作。

觀看來自外接裝置的圖像

選擇連接著外接裝置的VIDEO端子。

按下TV/VIDEO按鈕。

- 可用CHANNEL +/- 按鈕或從编排一覽選擇VIDEO端子。

調回電視頻道：

按下TV/VIDEO按鈕、CHANNEL +/- 按鈕或數字按鈕。

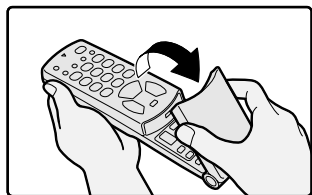

MUTING（靜音）按鈕

按下MUTING按鈕，關閉音量。再次按下MUTING按鈕，可恢復至原先的音量。

ZOOM（鏡頭）按鈕

可根據畫面縱橫比改變屏幕尺寸。請從下列镜头模式中選擇最合適的一個。

按下ZOOM按鈕，選擇一個模式。

- 如果在接收Progressive視頻信號（525P信號）時按下ZOOM按鈕，則會在屏幕上顯示“525P”，鏡頭功能不起作用。

常规

用於以原有尺寸觀看普通圖像（4:3縱橫比）。

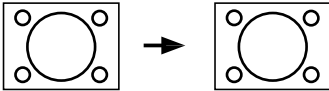

镜头

可將寬屏幕圖像（16:9縱橫比）充滿電視屏幕。

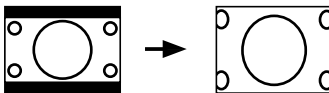

- 寬屏幕圖像（16:9縱橫比）的左側和右側將被去掉。

16:9

此模式將普通畫面（4:3縱橫比）轉變為寬屏幕畫面（16:9縱橫比）。

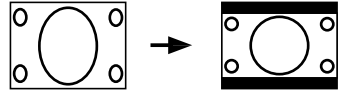

- 用於被壓縮成普通畫面（4:3縱橫比）的16:9縱橫比的畫面時，可恢復原來尺寸。

SPATIALIZER（環繞控制鍵）按鈕

利用环绕控制鍵功能，可欣賞帶有“現場”效果的環繞聲音。

按下SPATIALIZER按鈕，選擇模式。

现场：

利用現場模式，可欣賞被轉換成帶有深度和周圍環境的環繞聲音的普通立體聲。

单声道：

利用單聲道模式，可欣賞被轉換成像立體聲的普通單聲。

关：

環繞控制鍵功能不工作。

- 现场模式僅在立體聲時正常工作。
- 使用耳機時，现场模式不能正常工作。
- 单声道模式僅在單聲時正常工作。

SPATIALIZER係經Desper Products, Inc.公司授權製造。

遙控器按鈕和功能

BASS（低音）按鈕

利用超重低音（超重低音回聲）功能，可欣賞強勁有力的低音。

按下BASS按鈕，打開或關閉超重低音功能。

开：

打開此功能。

关：

關閉此功能。

PICTURE MODE（畫面模式）按鈕

可選擇三種畫面模式（三種畫面設定）中的一種，自動調節畫面設定。

按下PICTURE MODE按鈕，選擇模式。

亮度：

增強對比度和銳度。

普通：

標準畫面調節。

柔和：

使對比度和銳度變得柔和。

RETURN +（頻道調回+）按鈕

RETURN + 按鈕具有兩個功能：頻道調回+功能和頻道調回功能。如果某個頻道被登錄為“調回頻道”，則頻道調回+功能起作用。如未設定“調回頻道”，則頻道調回功能起作用。

頻道調回+功能：

將經常觀看的頻道登錄為“調回頻道”，可在任何時候僅需按下RETURN + 按鈕，就可選擇此頻道。

將電視頻道登錄為“調回頻道”：

選擇已設定節目號碼的需登錄頻道的節目號碼，並持續按住RETURN + 按鈕3秒鐘以上。將顯示“快退已設定！”，登錄結束。

取消“調回頻道”的登錄：

觀看任一電視頻道時，持續按住RETURN + 按鈕3秒鐘以上。將顯示“快退已取消！”，登錄被取消。

- 關閉電視機時，“調回頻道”的登錄被取消。
- 如想交替觀看“調回頻道”和另一電視頻道，請先選擇不是“調回頻道”的頻道，然後按下RETURN + 按鈕，將頻道轉換為“調回頻道”。用這一方法，僅需按下RETURN + 按鈕，便可交替觀看兩個頻道。

頻道調回功能：

電視機將當前電視頻道前選擇的電視頻道作為“最後頻道”暫時記憶下來。按下RETURN + 按鈕，可交替觀看當前電視頻道和“最後頻道”。

- 如想利用頻道調回功能交替觀看兩個頻道，請先選擇一個電視頻道，然後用數字按鈕選擇另一個電視頻道。如未用數字按鈕選擇電視頻道，則有可能不是將您先選擇的頻道登錄為“最後頻道”。

∞ ○ I/II 按鈕

觀看雙重語言聲音廣播節目時，可從雙重語言 I（副聲音 I）或雙重語言 II（副聲音 II）中選擇聲音。若接收立體聲廣播節目不理想時，可將立體聲改變為單聲，以便更清楚地收聽廣播。

按下 ∞ ○ I/II 按鈕，選擇聲音模式。

∞ : 立體聲

○ : 單聲

I : 雙重語言 I（副聲音 I）

II : 雙重語言 II（副聲音 II）

单声道：取消多聲道功能，聲音變成單聲道。

- 可選擇的聲音模式由電視節目而定。
- 在視頻模式時，此功能不起作用。

DISPLAY（顯示）按鈕

可在屏幕上顯示編排一覽、節目號碼或視頻端子號碼。

按下 DISPLAY 按鈕。

按下 DISPLAY 按鈕，如下所示地變換顯示：

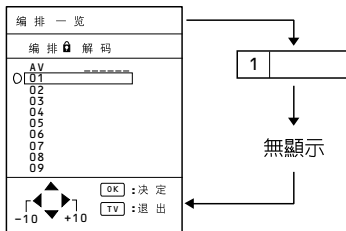

選擇電視頻道或視頻端子

1 按下 DISPLAY 按鈕，顯示編排一覽。

2 按下 ▲/▼ 和 ◀/▶ 按鈕，選擇節目號碼或視頻端子。

然後按下 MENU/OK 按鈕。

- 對於設有頻道鎖定功能的節目號碼，則會在編排一覽中的節目號碼旁顯示 （頻道鎖定）標記。
- 視頻端子登錄在節目號碼編排 99 之後。

COLOUR SYSTEM（彩色制式）按鈕

自動選擇彩色制式。但是，如果圖像不清晰或無色彩，請手動選擇彩色制式。

按下 COLOUR SYSTEM 按鈕，選擇合適的彩色制式。

自動：

此功能從輸入信號中檢測彩色制式。

- 如果信號品質不佳，則自動功能可能不能正常發揮作用。如在自動功能時畫面不理想，請手動選擇其他彩色制式。
- 自動模式從輸入信號中檢測彩色制式，並自動選擇合適的彩色制式。
- 需改變子畫面的彩色制式時，請參閱第 15 頁上的“改變子畫面的彩色制式”的詳細說明。
- 有關各國或各地區的彩色制式，請參閱第 12 頁上的“廣播制式”。

SOUND SYSTEM（聲音制式）按鈕

自動選擇聲音制式。但是，當畫面正常而卻不能正常地收聽聲音時，請手動選擇聲音制式。

按下SOUND SYSTEM按鈕，選擇合適的聲音制式。

B/G : B/G制式

I : I制式

D/K : D/K制式

M : M制式

- 在視頻模式時此功能不起作用。
- 有關各國或各地區的聲音制式，請參閱第12頁上的“廣播制式”。

廣播制式

有關所在國家或地區的聲音制式和彩色制式，請參閱下表。

彩色制式

區域	國家或地區	制式
亞洲、中東	巴林、科威特、阿曼、卡塔爾、阿拉伯聯合酋長國、也門等。 印度尼西亞、馬來西亞、新加坡、泰國、印度等。	PAL
	中國、越南等。	PAL
	香港等。	PAL
	伊朗回教共和國、黎巴嫩、沙特阿拉伯等。	SECAM
	菲律賓、台灣、緬甸等。	NTSC
歐洲	俄羅斯等。	SECAM
	捷克共和國、波蘭等。	PAL
	德國、荷蘭、比利時等。	PAL
	英國等。	PAL
澳洲	澳大利亞、新西蘭等。	PAL
非洲	南美共和國等。	PAL
	尼日利亞等。	PAL
	埃及、摩洛哥等。	SECAM

聲音制式

區域	國家或地區	制式
亞洲、中東	巴林、科威特、阿曼、卡塔爾、阿拉伯聯合酋長國、也門等。 印度尼西亞、馬來西亞、新加坡、泰國、印度等。	B/G
	中國、越南等。	D/K
	香港等。	I
	伊朗回教共和國、黎巴嫩、沙特阿拉伯等。	B/G
	菲律賓、台灣、緬甸等。	M
歐洲	俄羅斯等。	D/K
	捷克共和國、波蘭等。	D/K
	德國、荷蘭、比利時等。	B/G
	英國等。	I
澳洲	澳大利亞、新西蘭等。	B/G
非洲	南美共和國等。	I
	尼日利亞等。	B/G
	埃及、摩洛哥等。	B/G

FREEZE（畫面暫停）按鈕

可像子畫面一樣觀看主畫面的暫停圖像。

按下FREEZE按鈕。

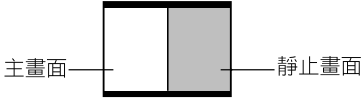

取消畫面暫停功能：

再次按下FREEZE按鈕。

- 當在屏幕上顯示子畫面或主畫面時，不可使用FREEZE按鈕。
- 如果在接收Progressive視頻信號（525P信號）時按下FREEZE按鈕，則會在屏幕上顯示“525P”，畫面暫停功能不起作用。

STROBE（頻閃）按鈕

可以15張連續的靜止圖像方式觀看主畫面。

按下STROBE按鈕。

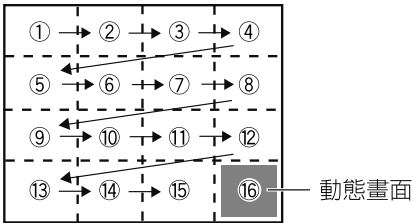

取消頻閃功能：

按下STROBE按鈕，回到主畫面。

- 如果主畫面的信號水準較弱，則靜止圖像不正常。
- 當在屏幕上顯示子畫面或主畫面時，不可使用STROBE按鈕。

- 如果在接收Progressive視頻信號（525P信號）時按下STROBE按鈕，則會在屏幕上顯示“525P”，頻閃功能不起作用。
- 即使是觀看NTSC彩色制式的節目，也不能改變對屏幕上的靜態圖像的色彩微調設定。

■ 使用多畫面功能

可顯示多個畫面，以便易於找到所需觀看的節目。

1 按下MULTI按鈕。

按下MULTI按鈕，如下所示地改變顯示。

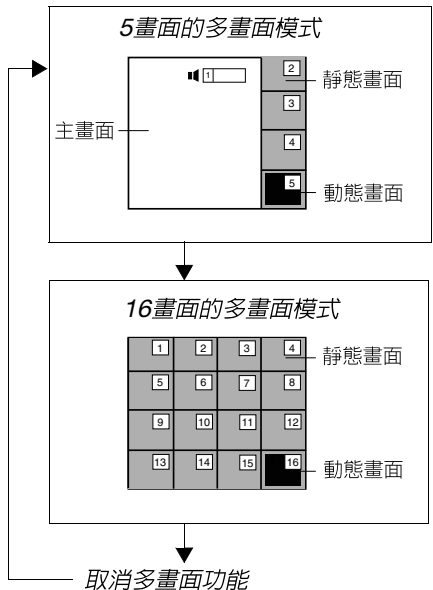

顯示下一個多畫面：

按下NEXT按鈕。

2 用 ▲/▼ 和 ◀/▶ 按鈕，選擇所需畫面，然後按下MENU/OK按鈕。

屏幕跳至所選的電視頻道或視頻模式。

- 不顯示未登錄電視頻道的節目號碼或設定頻道鎖定的節目號碼。
- 不能進行耳機音量調節等菜單操作。請先取消多畫面功能後，再進行菜單操作。
- 如果在接收Progressive視頻信號（525P信號）時按下MULTI按鈕，則會在屏幕上顯示“525P”，多畫面功能不起作用。
- 關閉多畫面顯示的一瞬間，電視機不發出聲音。

■ 使用PIP功能

可同時觀看兩個畫面（主畫面和子畫面）。

按下PIP按鈕。

按下PIP按鈕，如下所示地改變顯示：

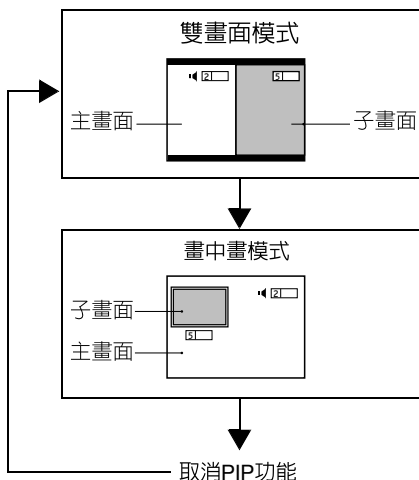

- 不可同時從主畫面和子畫面觀看同一節目號碼（或同一視頻端子）的圖像。
- 如果主畫面信號不佳，則子畫面的信號品質可能也較差。
- 如果兩個畫面的畫面標準不同，則頂部和底部或其中之一可能會沒有。
- 用PIP功能觀看畫面時，鏡頭功能不起作用。
- 不能從電視機輸出子畫面。
- 如果在接收Progressive視頻信號（525P信號）時按下PIP按鈕，則會在屏幕上顯示“525P”，PIP功能不起作用。

為子畫面選擇電視頻道

按下SUB-P -/+ 按鈕。

收聽子畫面的聲音

在收聽機內揚聲器發出的主畫面的聲音的同時，可用耳機收聽子畫面的聲音。
詳細說明，請參閱第23頁上的“耳机”。

改變子畫面的彩色制式

- 1 顯示子畫面時，按下MENU/OK按鈕，顯示菜單（主菜單）。
- 2 按下▲/▼和◀/▶按鈕，選擇畫面特征，然後按下MENU/OK按鈕。
- 3 按下▲/▼按鈕，選擇彩色制式，然後按下MENU/OK按鈕。



- 4 按下◀/▶按鈕，選擇子畫面，然後按下▲/▼按鈕，選擇合適的彩色制式。然後按下MENU/OK按鈕。
- 不能用遙控器上的COLOUR SYSTEM按鈕改變子畫面的彩色制式。

POSITION（位置）按鈕

利用畫中畫模式時，可調節子畫面的位置。

反復按下POSITION按鈕。

每按一次POSITION按鈕，子畫面按逆時針方向移動一次。

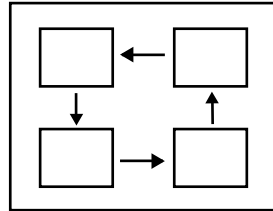

SWAP（交換）按鈕

可將主畫面和子畫面互換。

按下SWAP按鈕。

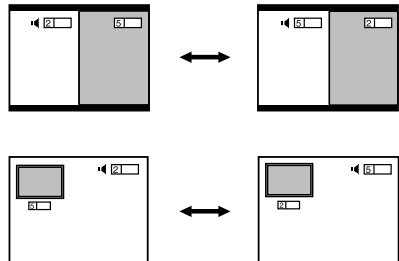

- 在將電視機輸出錄製在錄像機上時，請勿按下SWAP按鈕。如果按下SWAP按鈕，將會改變輸出信號。

使用電視機菜單

本電視機有許多可利用菜單進行操作的功能。

為了充分利用電視機的所有功能，需徹底理解基本的菜單操作技術。

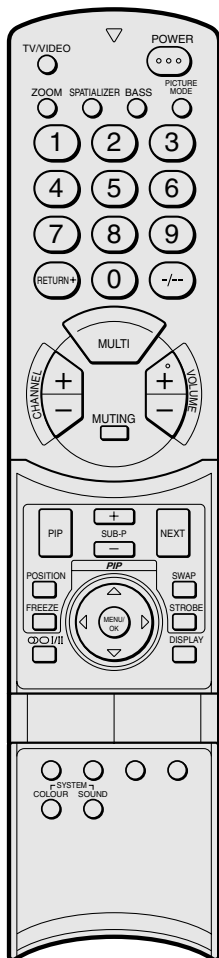

基本操作

- 1 按下MENU/OK按鈕，顯示菜單（主菜單）。



- 菜單底部的顯示說明操作所選功能時可使用的遙控器的按鈕。

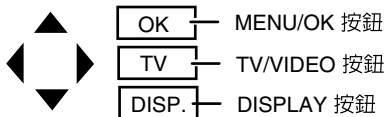

- 2 按下▲/▼和◀/▶按鈕，選擇菜單標題，並按下MENU/OK按鈕。
出現菜單。

返回到前一菜單：
按下DISPLAY按鈕。

立刻退出菜單：
按下TV/VIDEO按鈕。

- 3 按下▲/▼按鈕，選擇功能。
 - 有關菜單中的功能的詳細說明，請參閱下一頁開始的說明。

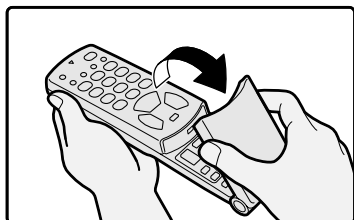

- 4 按下 ◀▶ 按鈕，選擇該功能的設定。
 - 如要操作僅顯示名字的功能，請根據下一頁開始的該功能的說明進行操作。
- 5 按下MENU/OK按鈕，結束設定。
 - 觀看NTSC制式的電視時，菜單顯示在正常垂直尺寸的約一半處。

用電視機上的按鈕進行操作

也可利用電視機前面板上的按鈕操作菜單。

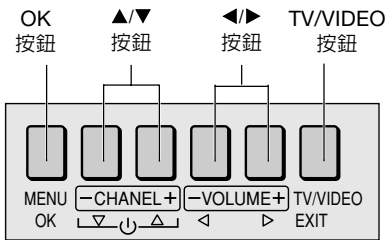

- 在電視機前面板上沒有具有DISPLAY或色彩按鈕功能的按鈕。

画面设定菜單

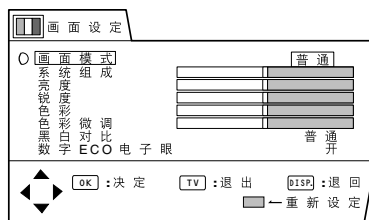

画面模式

可選擇三種画面模式中的一種，自動調節畫面設定。

亮度：
增強對比度和銳度。

普通：
標準畫面調節。

柔和：
使對比度和銳度變得柔和。

- 也可用遙控器上的PICTURE MODE按鈕操作画面模式。
詳細說明，請參閱第10頁上的“PICTURE MODE（畫面模式）按鈕”。

畫面調節

可根據需要，改變各畫面模式的畫面設定。改變的畫面設定被存儲於畫面模式內。

系统组成

可調節畫面對比度。

- ◀：較低
- ▶：較高

亮度

可調節畫面亮度。

- ◀：較暗淡
- ▶：較明亮

锐度

可調節畫面銳度。

- ◀：較柔和
- ▶：較尖銳

- 在接收Progressive視頻信號（525P信號）時，不能選擇畫面锐度功能。

色彩

可調節畫面色彩。

- ◀：較淡
- ▶：較濃

色彩微调

可調節畫面色彩微调。

- ◀：偏紅
- ▶：偏綠
- 僅當彩色制式為NTSC 3.58或NTSC 4.43時，可改變畫面色彩微调設定。
- 在接收Progressive視頻信號（525P信號）時，不能選擇畫面色彩微调功能。

返回到各画面模式的默認設定值：

按下藍色按鈕。將當前選擇的画面模式中的畫面設定值返回到默認設定值，並將其再次存儲於画面模式內。

■ 黑白对比

可選擇三種黑白對比模式（白色的三種色度）中的一種，調節畫面的黑白對比。因為白色被用於作為所有其他各種色彩的基準，所以改變黑白對比模式將影響屏幕上的所有其他各種色彩。

灰暗：

藍白色。觀看明亮圖像時使用這一模式，可欣賞生動明快的畫面。

普通：

普通白色。

暖色：

紅白色。觀看影片時使用這一模式，可欣賞影片所特有的色彩。

- 在雙畫面模式或镜头功能的16:9模式時，不能選擇黑白对比功能。

■ 数字ECO电子眼

如將数字ECO电子眼功能設定為开，則將根據房間的亮度自動調節屏幕的對比度。這可減輕眼睛疲勞並可節省電視機的電力。

开：

數字ECO電子眼功能工作。

关：

數字ECO電子眼功能不工作。

显示：

ECO電子眼功能工作。每當房間亮度變化時，表示房間亮度的三葉草標記 ♣ 會顯示幾秒鐘。房間變暗時，顯示在屏幕上的三葉草標記會增加。

画面特征菜單

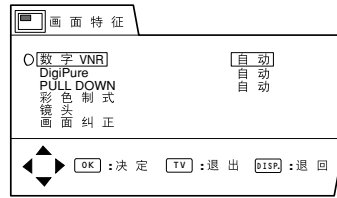

■ 数字VNR

数字VNR功能會減少原來圖像的噪音量。

- 在接收Progressive視頻信號（525P信號）時，不能選擇数字VNR功能。

自动：

電視機會根據畫面的噪音量自動調節数字VNR的效果，以顯示最佳畫面。

- 如果数字VNR效果設得太高，則會使畫面銳度太低。如有可能，推薦利用自动設定。

最大：

將数字VNR效果設為最大。若將数字VNR功能設定為自动但感到仍有噪音時，請將設定從自动改為最大。

- 最大設定不適合於帶有許多噪音的低質圖像。

最小：

將数字VNR效果設為最小。若將数字VNR功能設定為自动但感到未充分反映原來圖像的銳度時，請將設定從自动改為最小。

- 最小設定不適合於帶有很少噪音的高質圖像。

■ DigiPure

DigiPure功能利用最新數字技術，使畫面顯得自然。DigiPure功能包括下列兩個功能。

DigiPure功能：

此功能透過去除高對比度和鮮明圖像的無需的邊角，使畫面顯得自然。

而對於低對比度的圖像，則添加邊角，以變得更尖銳更清晰。

可從自動、最小和最大中選擇DigiPure功能的設定值。

畫面移動補償功能：

此功能可在屏幕上自然地顯示快速移動的圖像（例如足球場上的球員或足球）。

- 在接收Progressive視頻信號（525P信號）時，不能選擇DigiPure功能。

自動：

電視機會根據畫面的噪音量自動調節DigiPure的效果，以顯示最佳畫面。

- 如對帶有許多噪音的低質圖像將DigiPure效果設得太高，則可能會使噪音惡化。如有可能，推薦利用自動設定。

最大：

將DigiPure效果設為最大。若將DigiPure功能設定為自動但感到未充分反映原來圖像的品質時，請將設定從自動改為最大。

- 最大設定不適合於帶有許多噪音的低質圖像。

最小：

將DigiPure效果設為最小。若將DigiPure功能設定為自動但感到有噪音時，請將設定從自動改為最小。

- 最小設定不適合於帶有很少噪音的高質圖像。

關：

DigiPure功能不工作。

■ PULL DOWN

利用PULL DOWN功能可在屏幕上更清楚自然地顯示影片畫面。

自動：

下拉功能工作。一般將此功能設為自動。

關：

下拉功能不工作。

- 觀看NTSC彩色制式的動態圖像時可能會顯得不自然。為使動態圖像更清楚，請將PULL DOWN功能從自動改為關。
- 在雙畫面模式或畫面模式為畫面時不能選擇此功能。

■ 彩色制式

自動選擇彩色制式。但是，如果畫面不清晰或無色彩，請手動選擇彩色制式。

- 1 選擇彩色制式，然後按下MENU/OK按鈕。



- 2 按下◀/▶按鈕，選擇合適的彩色制式。然後按下MENU/OK按鈕。

- 改變子畫面的彩色制式時，請參閱第15頁上的“改變子畫面的彩色制式”詳細說明。
- 可用遙控器上的COLOUR SYSTEM按鈕操作彩色制式功能。詳細說明，請參閱第11頁上的“COLOUR SYSTEM（彩色制式）按鈕”。

■ 鏡頭

可根據畫面縱橫比改變屏幕尺寸。請選擇三種鏡頭模式中的最合適的一種。

- 1 選擇鏡頭，然後按下MENU/OK按鈕。

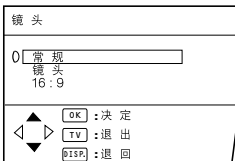

- 2 按下▲/▼按鈕，選擇鏡頭模式。然後按下MENU/OK按鈕。畫面擴展，並顯示所選的鏡頭模式約5秒鐘。

- 可從常規、鏡頭或16:9模式中選擇鏡頭模式。詳細說明，請參閱第9頁上的“ZOOM（鏡頭）按鈕”。
- 在接收Progressive視頻信號（525P信號）時，不能選擇鏡頭功能。

■ 畫面糾正

有的地方地球的磁力會使畫面歪斜。此時，可將其糾正。

- 1 選擇畫面糾正，然後按下MENU/OK按鈕。

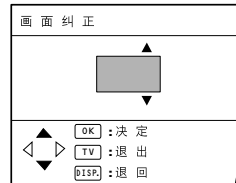

- 2 按下▲/▼按鈕，直至畫面變得水平。然後按下MENU/OK按鈕。

声音设定菜單

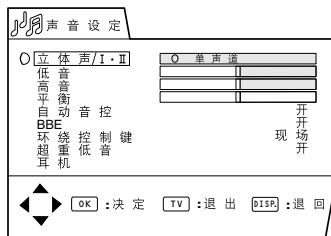

■ 立体声 / I · II

觀看雙重語言聲音廣播節目時，可從雙重語言 I（副聲音 I）或雙重語言 II（副聲音 II）中選擇聲音。若接收立體聲廣播節目不理想時，可將立體聲改變為單聲，以便更清楚地收聽廣播。

∞ : 立體聲

○ : 單聲

I : 雙重語言 I（副聲音 I）

II : 雙重語言 II（副聲音 II）

单声道 : 取消多聲道功能，聲音變成單聲道。

- 可選擇的聲音模式由電視節目而定。
- 在視頻模式時，此功能不起作用。

■ 聲音調節

可根據需要調節聲音。

低音

可調節聲音的低音。

- ◀ : 較弱
- ▶ : 較強

高音

可調節聲音的高音。

- ◀ : 較弱
- ▶ : 較強

平衡

可在左右揚聲器間調節音量的平衡。

- ◀ : 提高左揚聲器的音量。
- ▶ : 提高右揚聲器的音量。

■ 自动音控

當從一個頻道變到另一個頻道或從一種視頻模式變為另一種視頻模式時，可防止聲音突然變高或變低。

开 :

自動音控功能工作。

关 :

自動音控功能不工作。

- 可分別對電視模式和視頻模式設定自動音控功能。例如，可對電視模式設定為关，而對視頻模式設定為开。如果在觀看來自視頻端子的圖像時設定自動音控功能，則此設定值被登錄為對視頻模式的設定。
- 如果來自廣播電台（或視頻軟體）的聲音輸入水準極低，則自動音控功能可能不理想。

■ BBE

可利用BBE功能，欣賞易於收聽並忠實於所錄製的原有聲音的聲音。

开 :

BBE功能工作。

关 :

BBE功能不工作。

經BBE Sound, Inc. 許可。BBE是BBE Sound, Inc. 的註冊商標。

■ 环绕控制键

利用环绕控制键功能，可欣賞帶有“現場”效果的環繞聲音。可選擇兩種环绕控制键模式之一。

- 可從現場、单声道和关中選擇环绕控制键模式。詳細說明，請參閱第9頁上的“SPATIALIZER（環繞控制键）按钮”。

SPATIALIZER係經Desper Products, Inc.公司授權製造。

■ 超重低音

利用超重低音（超重低音回聲）功能，可欣賞強勁有力的低音。

开：

超重低音功能工作。

关：

超重低音功能不工作。

■ 耳机

利用耳机功能可將電視聲音從耳機輸出。

- 1 選擇耳机，然後按下MENU/OK按钮。

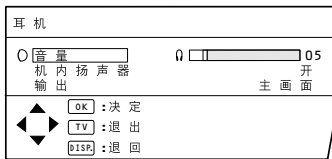

- 2 按下▲/▼按钮進行選擇，按下◀/▶按钮設定耳机功能。然後按下MENU/OK按钮。

音量：

可調節從耳機輸出的音量。

机内扬声器：

當此功能為开時，則即使連接耳機時也不關閉機內揚聲器。

如將此功能為关，則當連接耳機時機內揚聲器不輸出聲音。

输出：

使用耳機時，可選擇主畫面或子畫面的聲音。

- 機內揚聲器不輸出子畫面的聲音。
- 子畫面的音響祇能為單聲道。對於子畫面的音響不能使用立体声 / I · II功能。

便利功能菜單

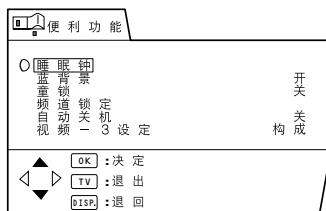

睡眠鐘

可將電視機設定為經過一段指定時間後自動關閉。

- 1 選擇睡眠鐘，然後按下MENU/OK按鈕。

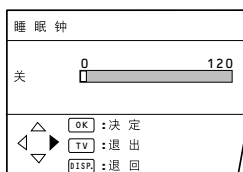

- 2 按下◀/▶按鈕，設定時間。
電視機開始從設定時間倒計數。

- 可以10分鐘為間隔設定時間，最大可設定為120分鐘（兩個小時）。

取消睡眠定時器功能：

按下◀按鈕，將時間設為“關”。

- 3 按下MENU/OK按鈕，結束設定。

菜單消失。

- 由睡眠鐘功能關閉電視機的前一分鐘，會顯示“晚安！”。
- 睡眠鐘功能不能用於關閉電視機的主電源。
- 設定睡眠鐘功能後，可再次顯示睡眠鐘功能菜單，以確認或改變剩餘時間。

藍背景

可將電視機設定為當信號較弱或無信號或者當外接裝置無輸入時自動變為藍背景，並靜音。

開：

藍背景功能工作。

關：

藍背景功能不工作。

童鎖

可使電視機的前面控制按鈕無效。將這一功能設定為開時，僅能用遙控器操作電視機。利用這一功能可防止兒童自行（未得到父母同意）操作電視機。

開：

童鎖功能工作。

關：

童鎖功能不工作。

頻道鎖定

如有不希望讓兒童觀看的電視頻道，可鎖定電視頻道。兒童選擇被鎖定的電視頻道所登錄的節目號碼時，屏幕會變成藍色，並顯示🔒，而不能觀看此電視頻道。

設定頻道鎖定功能

- 1 選擇頻道鎖定，然後按下數字0 (AV) 按鈕。

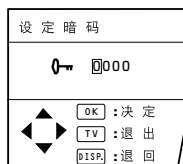

2 設定所需的解碼。

選擇數字：
按下 ▲/▼ 按鈕

移動遊標：
按下 ◀/▶ 按鈕。

3 按下MENU/OK按鈕。

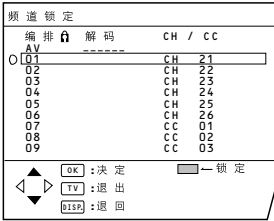

4 按下 ▲/▼ 按鈕，選擇電視頻道。

- 電視機顯示所選的正在播放的電視頻道的電視節目。

5 按下藍色按鈕，對此電視頻道設定頻道鎖定功能。

出現  (頻道鎖定)，此電視頻道被鎖定。

取消頻道鎖定功能：
再次按下藍色按鈕。
 (頻道鎖定) 消失，解除鎖定。

6 按下MENU/OK按鈕，結束設定。

菜單消失。

觀看鎖定的電視頻道

1 用數字按鈕或編排一覽選擇被鎖定的電視頻道所登錄的節目號碼。

屏幕變成藍色，並出現  (頻道鎖定)。

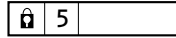

- 不能用 ▲/▼ 按鈕選擇鎖定的電視頻道。

2 按下DISPLAY按鈕，顯示“暗碼” (解碼輸入屏幕)。

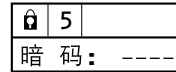

3 按下數字按鈕，輸入解碼。

鎖被暫時解開，可觀看此電視頻道。

如果忘記解碼：

執行“設定頻道鎖定功能”的第一步。
確認了解碼後，按下TV/VIDEO按鈕，退出菜單。

- 需取消頻道鎖定功能時，必須再次進行“設定頻道鎖定功能”的操作。

■ 自动关机

可將電視機設定為當廣播結束後15分鐘以上收不到信號時將其關閉。

开：

自動關機功能工作。

关：

自動關機功能不工作。

- 自动关机功能並不關閉電視機的主電源。
- 自动关机功能對視頻模式不起作用。

■ 视频-3设定

請根據VIDEO-3端子連接的外接裝置的視頻信號輸入正確設定视频-3設定。如果設定不正確，則不能顯示圖像。

视频：

若輸入普通視頻信號（複合視頻信號）。

构成：

若輸入構成視頻信號（Y/CB/CR信號）。

- 有關詳細的連接方法，請參閱第33頁上的“附加準備”。
- 僅當輸入構成視頻信號時，本機才與Progressive視頻信號（525P信號）相容。

導入菜單

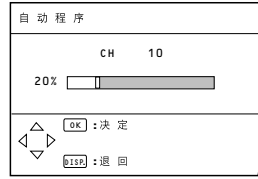
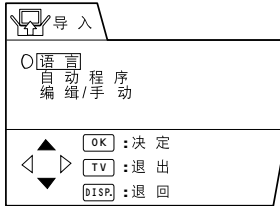

- 按下DISPLAY按鈕，取消自動程序功能。

语言

可從菜單的語言一覽表中選擇用於在屏幕上顯示的語言。

- 1 選擇語言，然後按下MENU/OK按鈕。



- 2 按下▲/▼按鈕，選擇一種語言。
- 3 按下MENU/OK按鈕，結束設定。
菜單消失。

自动程序

可按下列步驟，將在居住區域接收效果良好的電視頻道自動登錄在電視節目號碼內。

- 1 選擇自動程序，然後按下MENU/OK按鈕。

啟動自動程序功能。接收的電視頻道自動登錄於節目號碼一覽內。

- 2 電視頻道被登錄在節目號碼一覽內後，將出現編輯菜單。

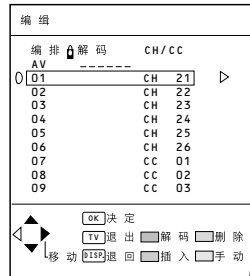

- 可利用編輯/手動功能編輯節目號碼一覽。詳細說明，請參閱第28頁上的“編輯/手動”。
- 如果想觀看的電視頻道未被設定在節目號碼一覽內，請利用手動功能將其登錄。詳細說明請參閱第28頁上的“編輯/手動”。
- 自動程序功能不將電視頻道登錄在節目號碼編排 0 (AV) 內。
- 如果不需使用編輯/手動功能，請按下MENU/OK按鈕，退出編輯菜單。

■ 编辑/手动

编辑/手动功能可分为两种类型：
当前节目号码的编辑（编辑功能）和将想要观看的电视频道手动登录到节目号码内（手动功能）。

注意

- 使用移动、删除或插入功能将重写当前的节目号码一览。
因此，将改变某些电视频道的节目号码。
- 将手动功能用于设有频道锁定功能的电视频道将取消对电视频道的频道锁定。
- 当有电视频道已被登录在编排 99中时，利用插入功能将删除此电视频道。

- 1 选择编辑/手动，然后按下MENU/OK按钮。

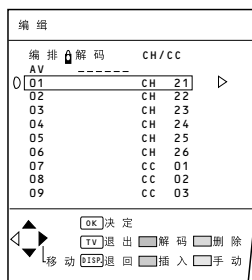

- 2 按照需利用的功能的操作说明操作功能。

移动：

此功能改变电视频道的节目号码。

解码：

此功能为电视频道登录频道名（解码）。

插入：

此功能利用CH/CC号码，将新的电视频道加入当前节目号码一览内。

删除：

此功能删除不需要的电视频道。

手动：

此功能将新的电视频道手动登录在节目号码内。

- 3 按下MENU/OK按钮，结束设定。

- 对于节目号码编排 0，“AV”将出现在节目号码一览中。

功能

移动

- 1 按下▲/▼按钮，选择电视频道。
- 2 按下▶按钮，启动移动功能。

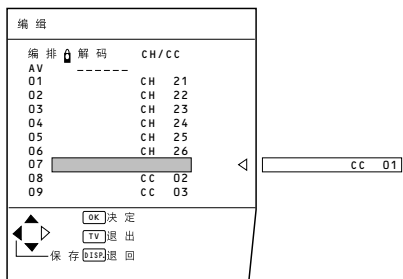

- 3 按下▲/▼按钮，选择新的节目号码。

取消移动功能：
按下DISPLAY按钮。

- 4 按下◀按钮，将电视频道的节目号码改变为新的节目号码。

解码

- 1 按下 ▲/▼ 按鈕，選擇電視頻道。
- 2 按下紅色按鈕，啓動解码功能。
- 3 輸入頻道名（解码）。
按下 ▲/▼ 按鈕，選擇字符。
按下 ◀/▶ 按鈕，移動遊標。

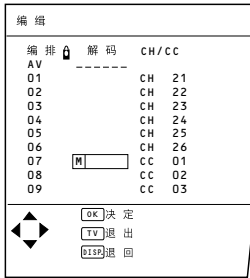

取消解码功能：
按下DISPLAY按鈕。

- 4 按下MENU/OK按鈕，為電視頻道登錄頻道名。

刪除

- 1 按下 ▲/▼ 按鈕，選擇電視頻道。
- 2 按下黃色按鈕，刪除電視頻道。
從節目號碼一覽中刪除此電視頻道。

手动

- 1 按下 ▲/▼ 按鈕，選擇想登錄的新電視頻道的節目號碼。
- 2 按下藍色按鈕，啓動手动功能。
在CH/CC號碼的右側，出現電視頻道的系統（聲音制式）。

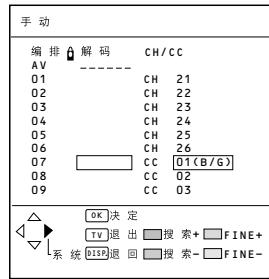

取消手动功能：
按下DISPLAY按鈕。

- 3 按下 ▶ 按鈕，選擇想登錄的電視頻道的制式（聲音制式）。
 - 有關各國或各地區的聲音制式，請參閱第12頁上的“廣播制式”表。
- 4 按下綠色或紅色按鈕，尋找電視頻道。
當電視機找到電視頻道時停下搜索，並顯示電視頻道。
- 5 反復按下綠色或紅色按鈕，直至出現所需的電視頻道。

若電視頻道接收不佳：
按下藍色或黃色按鈕，微調電視頻道。

如果能正常顯示電視頻道的畫面，卻不能正常收聽聲音：
系統的設定不正確。按下 ▶ 按鈕，選擇發出正常聲音的系統。

- 6 按下MENU/OK按鈕，將電視頻道登錄於節目號碼。
回到編輯菜單。

使用電視機菜單

插入

準備

- 請從第31頁上找到電視頻道的頻道號碼所對應的CH/CC號碼。

- 1 按下 ▲/▼ 按鈕，選擇想登錄的新電視頻道的節目號碼。
- 2 按下綠色按鈕，啓動插入功能。

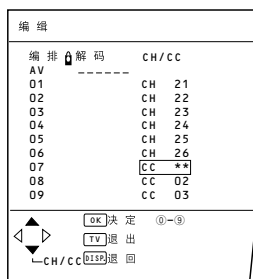

- 3 按下 ▲/▼ 按鈕，根據電視頻道的CH/CC號碼選擇“CC”或“CH”。

取消插入功能：

按下DISPLAY按鈕。

- 4 按下數字按鈕，輸入CH/CC號碼。

電視機轉換為登錄模式。

登錄結束時，此電視頻道的畫面會出現在屏幕上。

- CH/CC號碼是表示電視的廣播頻率的號碼。如果電視機檢測不到CH/CC號碼的廣播頻率所對應的電視頻道，則顯示無信號狀態的畫面。

CH/CC號碼

需利用第30頁上的插入功能時，請從下表找出對應於電視頻道的頻道號碼的CH/CC號碼。

US：美國頻道號碼是用於美國和菲律賓等國的頻道號碼。

CCIR：CCIR頻道號碼是用於中東和東南亞等地區的頻道號碼。

OIRT：OIRT頻道號碼是用於東歐、俄羅斯和越南等國的頻道號碼。

CHINA：中國頻道號碼。用於中國等國的頻道號碼。

AUSTRALIA：澳大利亞頻道號碼是用於澳大利亞等國的頻道號碼。

頻道						
CH	US	CCIR	OIRT	CHINA	AUSTRALIA	
CH 02	US-2	E2	R1	DS-1	AU-0	
CH 03	US-3	E3		DS-2	AU-1	
CH 04	US-4	E4	R2	DS-3	AU-2	
CH 05	US-5	E5	R6	DS-7	AU-6	
CH 06	US-6	E6	R7	DS-8	AU-7	
CH 07	US-7	E7	R8	DS-9	AU-8	
CH 08	US-8	E8	R9		AU-9	
CH 09	US-9	E9		DS-10		
CH 10	US-10	E10	R10	DS-11	AU-10	
CH 11	US-11	E11	R11	DS-12	AU-11	
CH 12	US-12	E12	R12	Z-8		
CH 13	US-13					
CH 14	US-14					
CH 15	US-15					
CH 16	US-16					
CH 17	US-17					
CH 18	US-18					
CH 19	US-19					
CH 20	US-20					
CH 21	US-21	E21		DS-13		
CH 22	US-22	E22		DS-14		
CH 23	US-23	E23		DS-15		
CH 24	US-24	E24		DS-16		
CH 25	US-25	E25		DS-17		
CH 26	US-26	E26		DS-18		
CH 27	US-27	E27		DS-19		
CH 28	US-28	E28		DS-20		
CH 29	US-29	E29		DS-21		
CH 30	US-30	E30		DS-22		
CH 31	US-31	E31		DS-23		
CH 32	US-32	E32		DS-24		
CH 33	US-33	E33				
CH 34	US-34	E34				
CH 35	US-35	E35				
CH 36	US-36	E36				
CH 37	US-37	E37				
CH 38	US-38	E38		DS-25		
CH 39	US-39	E39		DS-26		
CH 40	US-40	E40		DS-27		
CH 41	US-41	E41		DS-28		
CH 42	US-42	E42		DS-29		
CH 43	US-43	E43		DS-30		
CH 44	US-44	E44		DS-31		
CH 45	US-45	E45		DS-32		
CH 46	US-46	E46		DS-33		
CH 47	US-47	E47		DS-34		
CH 48	US-48	E48		DS-35		
CH 49	US-49	E49		DS-36		
CH 50	US-50	E50		DS-37		
CH 51	US-51	E51		DS-38		
CH 52	US-52	E52		DS-39		
CH 53	US-53	E53		DS-40		
CH 54	US-54	E54		DS-41		
CH 55	US-55	E55		DS-42		
CH 56	US-56	E56		DS-43		
CH 57	US-57	E57		DS-44		
CH 58	US-58	E58		DS-45		
CH 59	US-59	E59		DS-46		
CH 60	US-60	E60		DS-47		
CH 61	US-61	E61		DS-48		
CH 62	US-62	E62		DS-49		
CH 63	US-63	E63		DS-50		
CH 64	US-64	E64		DS-51		
CH 65	US-65	E65		DS-52		
CH 66	US-66	E66		DS-53		
CH 67	US-67	E67		DS-54		
CH 68	US-68	E68		DS-55		
CH 69	US-69	E69		DS-56		
CH 70				DS-57		

頻道						
CH	US	CCIR	OIRT	CHINA	AUSTRALIA	
CC 01		S-1			AU-5	
CC 02		S-2		Z-1		
CC 03		S-3		Z-2		
CC 04		S-4		Z-3		
CC 05		S-5		Z-4		
CC 06		S-6			AU-5A	
CC 07		S-7		Z-5		
CC 08		S-8		Z-6		
CC 09		S-9		Z-7		
CC 10		S-10		DS-6		
CC 11		S-11		Z-9		
CC 12		S-12		Z-10		
CC 13		S-13		Z-11		
CC 14	A	S-14				
CC 15	B	S-15		Z-12		
CC 16	C	S-16		Z-13		
CC 17	D	S-17		Z-14		
CC 18	E	S-18		Z-15		
CC 19	F	S-19		Z-16		
CC 20	G	S-20		Z-17		
CC 21	H	S-21		Z-18		
CC 22	I	S-22		Z-19		
CC 23	J	S-23		Z-20		
CC 24	K	S-24		Z-21		
CC 25	L	S-25		Z-22		
CC 26	M	S-26		Z-23		
CC 27	N	S-27		Z-24		
CC 28	O	S-28		Z-25		
CC 29	P	S-29		Z-26		
CC 30	Q	S-30		Z-27		
CC 31	R	S-31		Z-28		
CC 32	S	S-32		Z-29		
CC 33	T	S-33		Z-30		
CC 34	U	S-34		Z-31		
CC 35	V	S-35		Z-32		
CC 36	W	S-36		Z-33		
CC 37	W+1	S-37		Z-34		
CC 38	W+2	S-38		Z-35		
CC 39	W+3	S-39		Z-36		
CC 40	W+4	S-40		Z-37		
CC 41	W+5	S-41				
CC 42	W+6					
CC 43	W+7					
CC 44	W+8					
CC 45	W+9					
CC 46	W+10					
CC 47	W+11					
CC 48	W+12					
CC 49	W+13					
CC 50	W+14					
CC 51	W+15					
CC 52	W+16					
CC 53	W+17					
CC 54	W+18					
CC 55	W+19					
CC 56	W+20					
CC 57	W+21					
CC 58	W+22					
CC 59	W+23					
CC 60	W+24					
CC 61	W+25					
CC 62	W+26					
CC 63	W+27					
CC 64	W+28					
CC 75		X				
CC 76		Y	R3	DS-4		
CC 77		Z	R4	DS-5	AU-3	
CC 78		Z+1	R5			
CC 79		Z+2			AU-4	
CC 95	A-5					
CC 96	A-4					
CC 97	A-3					
CC 98	A-2					
CC 99	A-1					

演示菜單

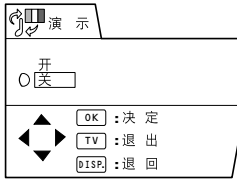

演示功能自動演示一些電視功能。

演示功能設定於開時：

每當打開電視機時，自動開始演示。
若不需演示，請將演示功能設為關。

- 1 按下 ▲/▼ 按鈕，選擇開。
選擇閉，則取消演示功能。
- 2 按下MENU/OK按鈕，結束設定。
將演示功能設定為開，開始演示。

停止演示：

按下遙控器上的任一按鈕。

附加準備

■ 連接外接裝置

將裝置連接於本電視機時，請參閱連接圖。

連接前：

- 請參閱裝置所附的說明書。有的裝置的連接方法與連接圖可能有所不同。另外，為了保證正常工作，可能需根據連接方法改變裝置的設定。
- 關閉包括電視機在內的所有裝置。
- 第40頁上的“技術規格”內有視頻端子的詳細說明。如果所需連接的裝置不在下列連接圖中，請參閱“技術規格”，選擇最合適的視頻端子。
- 未附帶連接電纜。
- 連接AV COMPU LINK支持的裝置時，請參閱第35頁上的“連接支持AV COMPU LINK的裝置”。

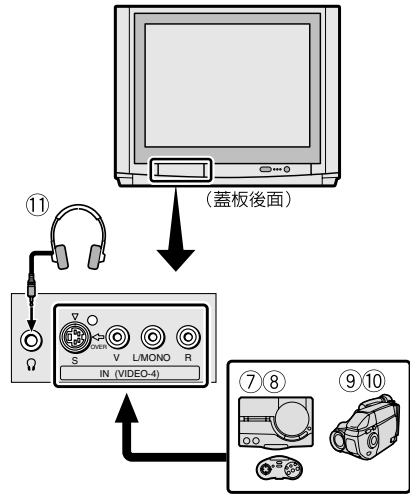

- ① VCR (複合信號)
- ② VCR (S-VIDEO (超級-視頻) 信號, Y/C)
- ③ 用於錄製的VCR (複合信號)
- ④ DVD放像機 (複合信號)
- ⑤ DVD放像機 (S-VIDEO (超級-視頻) 信號, Y/C)
- ⑥ DVD放像機 (構成視頻信號, Y/CB/CR)
- ⑦ 電視遊戲 (複合信號)
- ⑧ 電視遊戲 (S-VIDEO (超級-視頻) 信號, Y/C)
- ⑨ Camcorder (複合信號)
- ⑩ Camcorder (S-VIDEO (超級-視頻) 信號, Y/C)
- ⑪ 耳機
- A AV COMPU LINK電纜

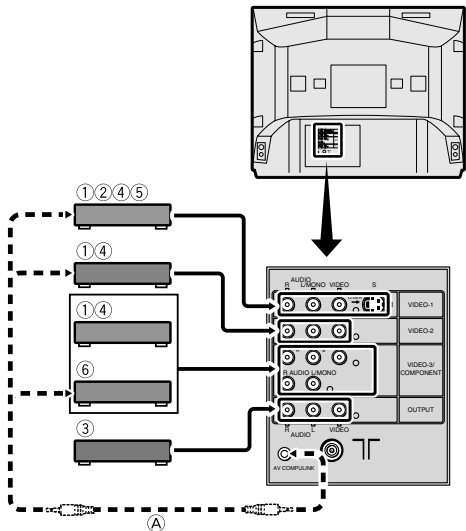

附加準備

連接方法

- 1 用視頻電纜將電視機的VIDEO插口和裝置的VIDEO OUT插口連接起來。

如果用S-VIDEO電纜將裝置連接於電視機：

用S-VIDEO電纜來代替視頻電纜，將VCR的S-VIDEO OUT接口和電視機的“S” (S-VIDEO) 接口連接起來。

同時用視頻電纜和S-VIDEO電纜將VCR與電視機連接時，用視頻電纜進行的連接將無效。

如果用構成視頻電纜將DVD放像機連接於電視機：

用構成視頻電纜來代替視頻電纜，將VIDEO-3端子的三個插口（Y/VIDEO、C_B和C_R）和DVD放像機的COMPONENT（構成視頻輸出）插口連接起來。然後按照第26頁上的“視頻-3設定”將視頻-3設定設定為構成。

- （當輸入構成視頻信號時，）本機與Progressive視頻信號（525P信號）相容。
- 如果DVD放像機作為構成視頻信號輸出Progressive視頻信號（525P），則當將該裝置用構成視頻電纜連接在電視機上時，可不失真地觀看錄製在DVD碟片上的圖像。

如果用視頻電纜將裝置連接於VIDEO-3/COMPONENT（視頻-3/構成）端子：

用視頻電纜將電視機的Y/VIDEO插口和裝置的VIDEO OUT插口連接起來。

然後按照第26頁上的“視頻-3設定”將視頻-3設定設定為視頻。

- 在VIDEO-4端子，VIDEO插口標示為“V”。

- 2 用音頻電纜將電視機的AUDIO插口（L/MONO和R）和裝置的AUDIO OUT（音頻L/R輸出）插口連接起來。

如果裝置的聲音輸出為單聲道：

用音頻電纜將裝置的AUDEO OUT插口和電視機的L/MONO插口連接起來。

將裝置連接於OUTPUT端子

透過OUTPUT端子輸出現在正用電視機觀看的畫面和聲音的信號。透過將VCR連接於OUTPUT端子，可將現正播放的圖像和聲音錄制在VCR上。此時，請按照下列步驟，將VCR和OUTPUT端子連接起來。

- 1 用音頻電纜將OUTPUT端子的VIDEO插口和VCR的VIDEO IN（視頻輸入）插口連接起來。
- 2 用音頻電纜將OUTPUT端子的AUDIO插口（L和R）和VCR的AUDIO IN（音頻L/R輸入）插口連接起來。
 - 關閉電視機時，來自OUTPUT端子的信號也將消失。
 - 來自VIDEO-3/COMPONENT端子的構成信號輸入不能透過OUTPUT端子輸出。

連接耳機

用立體聲微型插口（直徑3.5mm）將耳機與電視機前面板上的耳機插口連接起來。

■ 連接支持AV COMPU LINK的裝置

利用AV COMPU LINK遙控系統，可在操作一個裝置時，自動控制相關裝置。

如將此系統應用於本電視機，可在操作一個外接裝置時，自動進行電視機的所需操作，而無需用電視機的遙控器打開電視機或改變視頻模式。

AV COMPU LINK遙控系統的操作例

僅需按下VCR或DVD放像機上的PLAY按鈕，可觀看來自這些裝置的圖像。

僅需將預先錄製的錄像帶（去除錄製保護片的磁帶）插入VCR，可觀看錄像帶。

僅需操作AV控制接收器，可正確打開或關閉（待機模式）電視機或改變視頻模式。

- AV COMPU LINK遙控系統的性能因所連接的裝置而定。請參閱裝置的使用說明書。
- 當選擇“電視聲音”作為AV控制接收器的輸入音源時，有時電視機的靜音功能會自動啟動，機內揚聲器不發出聲音。此時，請按下電視機遙控器上的VOLUME +/- 按鈕或MUTING按鈕，取消靜音功能。可重新從機內揚聲器收聽聲音。

利用AV COMPU LINK遙控系統的條件

- 需帶有AV COMPU LINK端子的裝置。
- 須用AV COMPU LINK電纜連接電視機和裝置。本電視機不附帶AV COMPU LINK電纜。如沒有AV COMPU LINK電纜，請用兩端帶有直徑為3.5mm（單聲）的插入式插頭的電纜連接。
- 須將裝置連接於正確的VIDEO端子，並正確安裝。否則AV COMPU LINK遙控系統不能正確發揮作用。詳細說明，請參閱“安裝AV COMPU LINK遙控系統”。
- 電視機須為待機模式（POWER指示燈亮紅燈）。如果電視機的主電源處於關閉狀態（POWER指示燈熄滅），AV COMPU LINK遙控系統將不起作用。

安裝AV COMPU LINK遙控系統

注意：

- 有些裝置的安裝方法不同於此處說明的方法。安裝前，請務必通讀該裝置的使用說明書。

- 1 將裝置連接於電視機的VIDEO-1或VIDEO-2端子。

如用構成視頻電纜將DVD放像機和電視機連接起來：

將DVD放像機和電視機的VIDEO-3端子連接起來。

- 有關連接方法的詳細說明，請參閱第33頁上的“連接外接裝置”。

附加準備

- 2 用AV COMPU LINK電纜將電視機的AV COMPU LINK端子和裝置的AV COMPU LINK端子連接起來。
- 3 根據所連接的VIDEO端子改變裝置的設定。

如果VCR連接於VIDEO-1端子：

將VCR的遙控碼設為A碼。

如果DVD放像機連接於VIDEO-1端子：

將DVD放像機的AV COMPULINK MODE設為DVD2。

如果VCR連接於VIDEO-2端子：

將VCR的遙控碼設為B碼。

如果DVD放像機連接於VIDEO-2端子：

將DVD放像機的AV COMPULINK MODE設為DVD3。

如果用構成視頻電纜將DVD放像機與VIDEO-3端子相連接：

將DVD放像機的AV COMPULINK MODE設為DVD1。

- 有關改變裝置的設定的詳細說明，請參閱該裝置的使用說明書。
- 如果所連接的裝置既無遙控碼，也無AV COMPULINK MODE時，請將其連接於電視機的VIDEO-1端子。

故障排除

如果使用本電視機時發生問題，請在提出修理前仔細閱讀此“故障排除”。可能會很方便地自己解決問題。例如，如果交流電源插頭未插入交流電源插座或電視機天線有問題，而您卻可能懷疑是電視機的問題。

重要：

- 此故障排除指南僅包括難於確定原因的問題。如果在操作某一功能時發生問題，請參閱說明該功能的操作之頁，而不是此故障排除指南。
- 在按照此故障排除的說明或有關功能的操作說明操作後仍無進展，請將交流電源插頭從交流電源插座上拔下，讓人修理電視機。請勿自行修理電視機或拆下後蓋。

■ 如果不能打開電視機

- 交流電源插頭是否插入交流電源插座？
- POWER指示燈是否亮燈？如未亮燈，請按下主電源按鈕。

■ 無畫面或無聲音

- 是否所選擇的電視頻道的接收效果特差？若如此，會啟動藍背景功能，整個屏幕會變成藍色，聲音變為靜音。如需觀看此電視頻道，請按照第24頁上的“藍背景”的說明，將藍背景功能設定為關。
- 電視頻道的聲音制式的設定值是否正確？請按照第12頁上的“SOUND SYSTEM（聲音制式）按鈕”解決問題。

■ 畫面不清楚

- 如果整個畫面不清楚（雪花圖像），則天線或天線電纜可能有問題。請進行下列檢查，解決問題：

電視機和天線是否正確連接？

天線電纜是否損壞？

天線是否指向正確方向？

天線是否損壞？

- 如果電視機或天線的接收受到其他裝置的干擾，在畫面上可能會出現條狀或噪音。將擴音器、個人電腦或吹風器等會干擾電視機的裝置從電視機旁移開，或改變位置。如果天線受到無線電發射塔或高壓線的影響，請向當地的供銷商洽詢。
- 如果電視機受到來自大山或大樓的信號反射的干擾，會出現雙重圖像（重影）。請改變天線的方向或將其換成具有更佳方向性的天線。
- 電視頻道的彩色制式的設定值是否正確？請按照第11頁上的“COLOUR SYSTEM（彩色制式）按鈕”解決問題。
- 是否正確調節色彩或亮度？請按照第18頁上的“畫面調節”正確調節。

故障排除

- 當在屏幕上顯示白亮的靜止圖像（例如白色服裝），白色部分可能會看上去像是彩色的。這是因顯像管的特性而引起的不可避免的現象，而不是電視機的故障。
當圖像從屏幕上消失後，這一不自然的色彩也會跟著消失。
- 觀看市售的未正確錄製的視頻軟體或錄像帶時，圖像頂部可能會變形。
這是因視頻信號而引起的，而不是故障。
- 接收Progressive視頻信號（525P信號）時，下列功能無效：
遙控器功能：
ZOOM、PIP、MULTI、FREEZE和STROBE按鈕
菜單功能：
銳度、色彩微調、數字VNR、Digipure和鏡頭。

聲音不清楚

- 是否正確調節低音或高音？若未正確調節，請按照第22頁上的“聲音調節”正確調節。
- 電視頻道接收不佳時，可能較難收聽立體聲或雙重語言聲音。此時，請按照第22頁上的“立體聲/I·II”的說明，將其改為單聲道，以更清晰地收聽。

不能操作

- 遙控器的電池是否耗盡？
請按照第4頁上的“將電池裝入遙控器”的說明，換上新電池，解決問題。
- 是否在電視機的側面或後面或者在離電視機7米以上之處使用遙控器？請在電視機的前面或在離電視機7米以內使用遙控器。
- 是否將童鎖功能設定為開？如果將童鎖功能設定為開，則不能用電視機的前面控制按鈕操作電視機。請按照第24頁上的“童鎖”的說明，將童鎖功能設定為關。
- 如果突然不能操作電視機，請按下電視機的主電源按鈕，關閉主電源。再次按下主電源按鈕，打開主電源。如果電視機恢復正常狀態，則未出故障。

其他說明

- 當睡眠钟功能或自动关机功能工作时，電視機將自動關閉。
如果電視機突然關閉，請按下POWER按鈕，再次打開電視機。如果此時電視機工作正常，則無問題。
- 使用耳機時，如果不想從機內揚聲器發出聲音，請將耳机菜單中的机内扬声器設定改爲關。詳細說明，請參閱第23頁上的“耳机”
- 如將揚聲器之類的磁性裝置放在電視機的附近，在屏幕的邊角上畫面可能會重疊或色彩不自然。此時，請將該裝置遠離電視機。如果因揚聲器產生這一現象，請使用磁屏蔽揚聲器。
- 畫面可能因地球磁性的影響而歪斜。此時，請按照第21頁上的“画面纠正”，糾正歪斜。
- 進行頻道等操作時，需稍等片刻方能出現圖像。這不是故障。這是因爲需待圖像穩定後方能顯示。
- 因溫度的突然變換，電視機可能會發出劈啪的響聲。如果圖像和聲音正常，則無問題。如果觀看電視時，經常聽見劈啪的響聲，則可能是由其他原因造成的。
爲了小心起見，請讓技術服務人員檢查一下。
- 觸摸屏幕表面時，可能會感到由靜電引起的輕微的觸電。
這是由顯像管的結構引起的不可避免的現象，而不是電視機的問題。
請休息一會，該靜電放電不會對人體造成有害影響。

技術規格

廣播制式	B、G、I、D、K、K1、M
彩色制式	PAL、SECAM、NTSC3.58/4.43MHz
頻道和頻率	VHF低頻道 (VL) = 46.25至168.25 MHz VHF高頻道 (VH) = 175.25至463.25 MHz UHF頻道 (U) = 471.25至863.25 MHz ■ 可接收中頻段 (X至Z+2、S1至S10)、高頻段 (S11至S20) 和超高頻段 (S21至S41) 的有線頻道。
多聲道制式	A2 (B/G)、NICAM (B/G、I、D/K) 制式
電源要求	交流110至240V，50/60 Hz
音頻輸出	額定功率輸出：20W + 20W
VIDEO-1 (視頻-1) 端子	RCA接口×3、S-VIDEO (超級-視頻) 接口×1 · 備有視頻輸入、S-VIDEO (超級-視頻) (Y/C) 輸入和音頻L/R輸入。
VIDEO-2 (視頻-2) 端子	RCA接口×3 · 備有視頻輸入和音頻L/R輸入。
VIDEO-3/COMPONENT (視頻-3/構成) 端子	RCA接口×5 · 備有視頻輸入/構成視頻 (Y/Cb/Cr) 輸入和音頻L/R輸入 · 備有Progressive視頻信號 (525P信號) 輸入。
VIDEO-4 (視頻-4) 端子	RCA接口×3、S-VIDEO (超級-視頻) 接口×1 · 備有視頻輸入、S-VIDEO (超級-視頻) (Y/C) 輸入和音頻L/R輸入。
OUTPUT (輸出) 端子	RCA接口×3 · 備有視頻輸出和音頻L/R輸出。
耳機插口	立體聲微型插口 (直徑3.5mm)
附件	遙控器×1 (RM-C215) AA/R6/5號乾電池×2
揚聲器	HV-34LPZ：12cm 圓形×2，3.5cm 圓形×2 HV-29LPZ：10cm 圓形×2，3.5cm 圓形×2
消耗功率	HV-34LPZ：最大255W，平均170W HV-29LPZ：最大254W，平均170W
屏幕尺寸 (對角測量)	HV-34LPZ：顯像管87cm 可視範圍80cm HV-29LPZ：顯像管73cm 可視範圍68cm
尺寸 (寬×高×長)	HV-34LPZ：898mm×728mm×579mm HV-29LPZ：732mm×588mm×518mm
重量	HV-34LPZ：75kg HV-29LPZ：48kg

設計和規格如有變更，恕不另行通知。

因涉及到侵犯版權的問題，不得到原有圖像版權主的同意，利用本電視機的鏡頭功能顯示在屏幕上的圖像不得用於在公共場所 (餐館、賓館等) 的商業或演示目的的顯示。

JVC
VICTOR COMPANY OF JAPAN, LIMITED

JVC



COLOUR TELEVISION

HV-34LPZ HV-29LPZ

InteriArt
Premiere

DigiPure

100Hz & PROGRESSIVE SCAN

Contents

Setting up your TV	3
TV buttons and functions	6
Remote control buttons and functions	8
Using the TV's menu	18
Basic operation	18
PICTURE SETTING menu	20
PICTURE FEATURES menu	21
SOUND SETTING menu	24
FEATURES menu	26
INSTALL menu	29
DEMO menu	35
Additional preparation	36
Troubleshooting	40
Specification	43

INSTRUCTIONS



Thank you for buying this JVC colour television.

To make sure you understand how to use your new TV, please read this manual thoroughly before you begin.

WARNING:

TO PREVENT FIRE OR SHOCK HAZARD, DO NOT EXPOSE THIS APPLIANCE TO RAIN OR MOISTURE.

CAUTION:

TO ENSURE PERSONAL SAFETY, OBSERVE THE FOLLOWING RULES REGARDING THE USE OF THIS TV.

- 1 Operate only from the power source indicated on the rear of the TV.
- 2 Avoid damaging the power cord and mains plug. When unplugging the TV, grasp the mains plug. Do not pull on the power cord.
- 3 Never block or cover the ventilation openings.
Never install the TV where good ventilation is unattainable.
When installing this TV, leave spaces for ventilation around the TV of more than the minimum distances as shown.

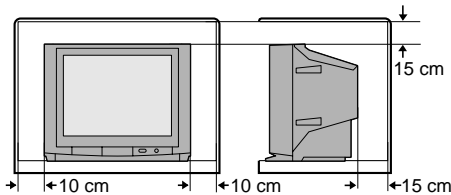

- 4 Do not allow objects or liquid into the cabinet openings.
- 5 In the event of a fault, unplug the unit and call a service technician.
Do not attempt to repair it yourself or remove the rear cover.
- 6 The surface of the TV screen is easily damaged. Be very careful with it when handling the TV. Should the TV screen become soiled, wipe it with a soft dry cloth. Never use rub it forcefully.
Never use any cleaner or detergent on it.
- 7 If you are not going to use this TV for a long period of time, be sure to disconnect the AC plug from the AC socket.

Setting up your TV

CAUTION

- Turn off all the equipment including the TV before connecting anything.

1 Connecting the aerial and VCR

- Aerial cable is not supplied. Use a good quality 75-ohm coaxial cable.
- Read the manual that came with the VCR before connecting.

If not connecting a VCR (see fig.A) :

Connect an aerial cable to the aerial socket on this TV .

If connecting a VCR (see fig.B) :

- 1 Connect the aerial cable to the aerial socket on the VCR, and connect the VCR and TV with another aerial cable.
- 2 Connect the VCR's VIDEO OUT (video output) jack and the TV's VIDEO jack with a video cable.

To connect a VCR to the TV with an S-VIDEO cable:

Connect the VCR's S-VIDEO OUT (S-VIDEO output) connector and TV's S connector with an S-VIDEO cable (A), instead of connecting with a video cable .

- 3 Connect the VCR's VIDEO OUT (audio L/R output) jacks and the TV's AUDIO jacks (L/MONO and R) with an audio cable.

- If the VCR's audio output is in mono, connect the VCR's AUDIO OUT (audio output) jack and the TV's AUDIO L/MONO jack with an audio cable.
- You can use the AV COMPU LINK function if your VCR has an AV COMPU LINK terminal. For details, see "Connecting AV COMPU LINK Supported Devices" on page 38.

Fig.A

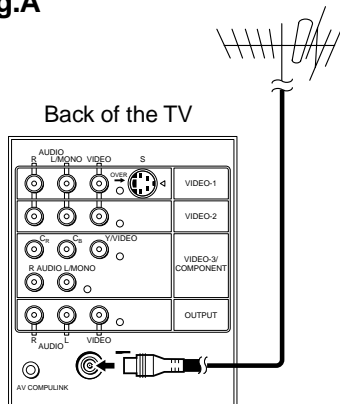
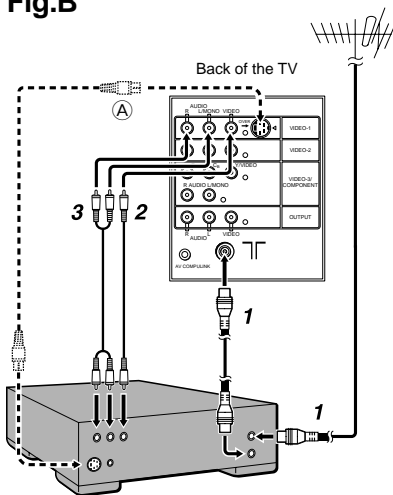

Fig.B



2 Connecting the power cord

Connect the mains plug to the AC outlet.

3 Putting the batteries into the Remote control

Use two AA/R6 batteries.

Insert the batteries from the ⊖ end, making sure the ⊕ and ⊖ polarities are correct.

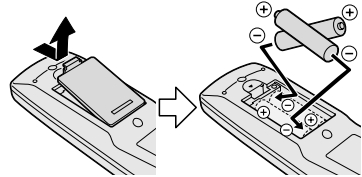

- Follow the warnings printed on the batteries.
- If the remote control does not work properly, replace the batteries.
- The batteries we supply are only for setting up and testing your TV. Please replace them as soon as necessary.

4 Making the initial settings

When the TV is first turned on, it enters the initial setting mode, and the JVC logo is displayed.

1 Press the main power button on the TV

The TV is turned on, and the JVC logo appears.

- If the power lamp on the TV lights red and does not change to green, your TV is in the standby mode. Press the POWER button on the remote control to turn the TV on.
- If the JVC logo does not appear, your TV has already been turned before. In this case, use the "LANGUAGE" and "AUTO PROGRAM" functions to make the initial settings. For details, see "INSTALL menu" on page 29.

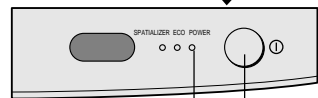
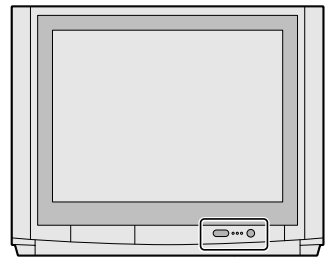

POWER lamp

Main power button

2 Press the MENU/OK button

The LANGUAGE menu appears. You can choose a language for the on-screen language.

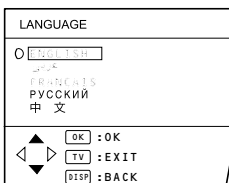

3 Press the ▲/▼ buttons to choose ENGLISH. Then press the MENU/OK button.

The AUTO PROGRAM function starts. The TV channels you receive are automatically stored in the programme numbers list.

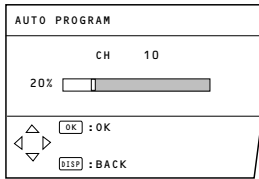

- To cancel the AUTO PROGRAM function, press the DISPLAY button.

4 After the TV channels have been stored in the programme number (PR) list, the EDIT menu appears.

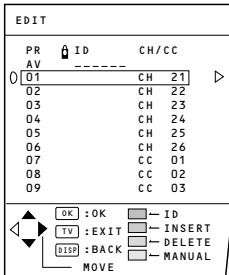

- You can proceed to edit the programme numbers list using the EDIT/MANUAL function. For details, see "EDIT/MANUAL" on page 30.
- If a TV channel you want to view is not stored in the programme numbers list, you can register it using the MANUAL function. For details, see "EDIT/MANUAL" on page 30.
- The AUTO PROGRAM function does not store a TV channel to the programme number 0 (AV).
- If you do not need to use the EDIT/MANUAL function, press the MENU/OK button to close the EDIT menu.

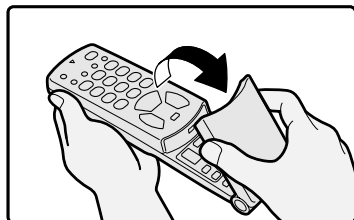
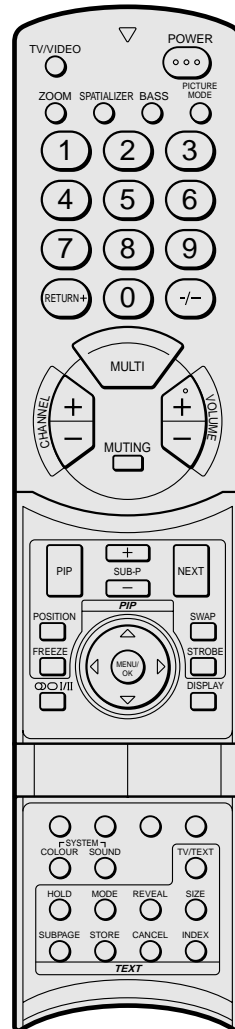

Now, the setting up is complete. Please enjoy your new JVC TV!

TV buttons and functions

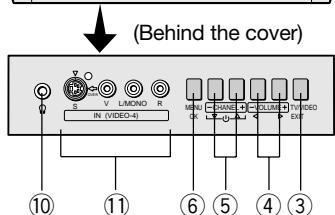
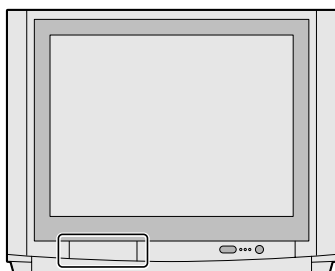
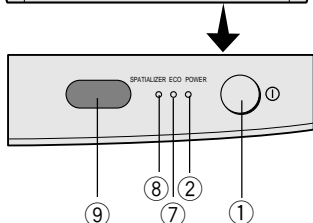
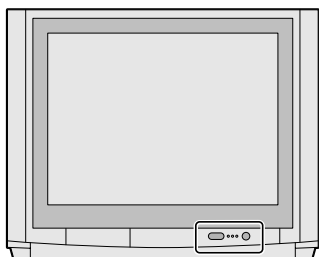

Turn the main power on

Press the main power button ① .

The POWER lamp ② lights red and your TV is in the standby mode.

To turn the main power off :
press the main power button again.
The POWER lamp ② goes off.

Turn the TV on from standby mode

Press the CHANNEL-/+ buttons ⑤ .

The POWER lamp ② lights red to green and your TV will be turned on.

- You can also turn on the TV by pressing the TV/VIDEO button ③ while it is in standby mode.

Choose a TV channel

Press the CHANNEL-/+ buttons ⑤ .

Choose a VIDEO terminal

Press the TV/VIDEO button ③ or CHANNEL-/+ buttons ⑤ .

Adjust the volume

Press the VOLUME-/+ buttons ④ .

The volume level indicator appears.

MENU button ⑥

Press to open the menu.

For details, see "Operation with the buttons on the TV" on page 19.

Remote control sensor and ECO sensor ⑨

ECO lamp ⑦

If you set the DIGITAL ECO SENSOR function to ON or DISPLAY, the ECO lamp lights.

SPATIALIZER lamp ⑧

If you set the SPATIALIZER function to MONO or LIVE, the SPATIALIZER lamp lights.

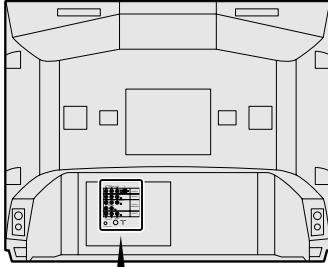

Headphone jack ⑩

Connect the headphones with a stereo mini-jack (3.5mm in diameter). When using the headphones, follow the operation procedure "HEADPHONE" on page 25.

VIDEO-1 terminal ⑫

- See page 3 and 36.

VIDEO-2 terminal ⑬

- See page 36.

VIDEO-3/COMPONENT terminal ⑭

- See page 28 and 36.

VIDEO-4 terminal ⑪

- See page 36.

OUTPUT terminal ⑮

- See page 36.

Aerial socket ⑯

Connect the aerial cable.

- See page 3.

AV COMPU LINK terminal ⑰

- See page 36 and 38.

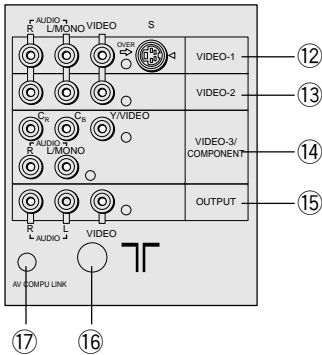

Remote control buttons and functions

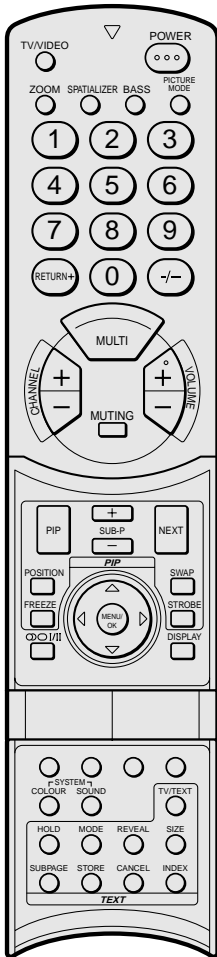

Turn the TV on from standby mode

Press the POWER button.

The POWER lamp lights red to green and your TV will be turned on.

- You can turn on the TV from the standby mode by pressing the TV/VIDEO button, the CHANNEL +/- buttons or the number buttons.

To turn the TV off:

Press the POWER button again.

The POWER lamp changes from green to red and the TV enters standby mode.

Choose a TV channel

Choose a programme number in which a TV channel has been set.

Press the CHANNEL +/- buttons or enter the programme number (PR) with the number buttons.

- If you want to put a two-digit channel into the TV, press the -/--button to change to the two-digit entry system.
- You can select a channel from the PR LIST. For details, see "DISPLAY button" on page 11.
- If you do not have a clear picture or no colour appears, follow the operation procedure "COLOUR SYSTEM button" on page 11.
- If you cannot hear sound normally even when the picture appears normally, follow the operation procedure "SOUND SYSTEM button" on page 12.

Adjust the volume

Press the VOLUME +/- buttons.

- You cannot adjust the volume of your headphones. Follow the operation procedure "HEADPHONE" on page 25.

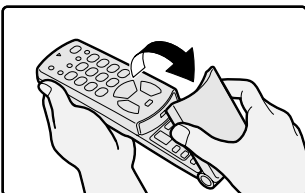

Watch images from external devices

Choose a VIDEO terminal to which the external device has been connected.

Press the TV/VIDEO button.

- You can choose a VIDEO terminal with the CHANNEL +/- buttons or from the PR LIST.

To return to a TV channel:

Press the TV/VIDEO button, the CHANNEL +/- buttons or the number buttons.

MUTING button

Press the MUTING button to turn off the volume. Pressing the MUTING button again resumes the previous volume level.

ZOOM button

You can change the screen size according to the picture aspect ratio. Choose the optimum one from the following ZOOM modes.

Press the ZOOM button to choose a mode.

- If you press the ZOOM button when receiving the Progressive Video Signal (525P signal), "525P" appears on the screen and the ZOOM function does not operate.

REGULAR

Use to view a normal picture (4:3 aspect ratio) as its original size is.

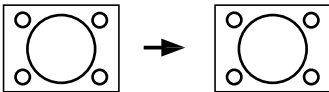

ZOOM

You can zoom up the Wide picture (16:9 aspect ratio) to fill the TV screen.

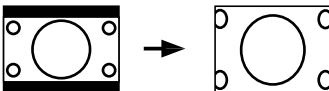

- The left side and right side of the Wide picture (16:9 aspect ratio) will be cut off.

16:9

This mode converts a normal picture (4:3 aspect ratio) into a Wide picture (16:9 aspect ratio).

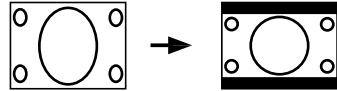

- Use for picture with a 16:9 aspect ratio that have been squeezed into a normal picture (4:3 aspect ratio), you can restore their original dimensions.

SPATIALIZER button

You can enjoy Surround sound with a "live" effect by using the SPATIALIZER function.

Press the SPATIALIZER button to choose a mode.

LIVE :

Live allows you to enjoy normal stereo sound converting it into surround sound with added depth and ambience.

MONO :

Mono allows you to enjoy normal monaural sound by converting it into a stereo-like sound.

OFF :

This function is turned off.

- The LIVE mode works properly only with stereo sound.
- The LIVE mode does not work correctly with headphones.
- The MONO mode works properly only with monaural sound.

The SPATIALIZER is manufactured under license from Desper Products, Inc.

BASS button

You can enjoy a powerful bass sound by using the SUPER BASS(Super Bass Reflex) function.

Press the BASS button to turn the SUPER BASS function on or off.

ON :

This function is turned on.

OFF :

This function is turned off.

PICTURE MODE button

You can choose one of three PICTURE MODEs (three kinds of picture setting) to adjust the picture settings automatically.

Press the PICTURE MODE button choose a mode.

BRIGHT :

Heightens contrast and sharpness.

STANDARD :

Standardizes picture adjustment.

SOFT :

Softens contrast and sharpness.

RETURN+ button

The RETURN+ button has two functions; the RETURN+ function and the RETURN function. If a channel has been registered as the "Return Channel", the RETURN+ function operates. If there is no setting for the "Return Channel", the RETURN function operates.

RETURN+ function :

By registering a channel you frequently view as the "Return Channel", you can select that channel at any time simply by pressing the RETURN+ button.

To register a TV channel as the "Return Channel" :

Choose the Programme number to which the channel you want to register has been set, and press the RETURN+ button and hold for more than 3 seconds continuously. "RETURN PLUS PROGRAMMED!" is displayed and the registration is completed.

To cancel register a TV channel as the "Return Channel" :

while viewing any TV channel, press the RETURN+ button and hold for more than 3 seconds continuously. "RETURN PLUS CANCELED!" is displayed and the registration is cancelled.

- When you turn off the TV, the registration for the "Return Channel" is cancelled.
- If you want to view the "Return Channel" and another TV channel alternately, first choose a channel other than the "Return Channel". and then press the RETURN+ button to change the channel to the "Return Channel" In this way, you can view two channels alternately by pressing the RETURN+ button.

RETURN function :

The TV temporarily memorises the TV channel that was chosen right before the current TV channel as the "Last Channel". By pressing the RETURN+ button, you can alternately view the current TV channel and the "Last Channel".

- If you want to view two channels alternately by using the RETURN function, first choose one TV channel and then choose the other TV channel with the Number buttons. If you choose the TV channel without using the Number buttons, there are cases where a channel other than the one you first chose is registered as the "Last Channel".

∞ ○ I/II button

When you are viewing a bilingual broadcast programme, you can choose the sound from Bilingual I (Sub I) or Bilingual II (Sub II). When the stereo broadcasting is received poorly, you can change from stereo to mono sound so that you can hear the broadcast more clearly and easily.

Press the ∞ ○ I/II button to choose a sound mode.

- ∞ : Stereo sound
- : mono sound
- I : Bilingual I (sub I)
- II : Bilingual II (sub II)
- MONO : Cancels the Multi Sound function, and the sound becomes monaural.

- The sound mode you can choose differs depending on the TV programme.
- This function does not work in the VIDEO modes.

DISPLAY button

You can display the PR LIST, programme number or VIDEO terminal number on the screen.

Press the DISPLAY button.

Press the DISPLAY button changes the display as follows:

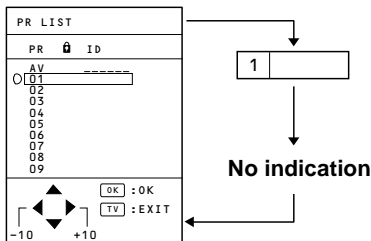

Choose a TV channel or a VIDEO terminal

- 1 Press the DISPLAY button to display the PR LIST.
- 2 Press the ▲/▼ and ◀/▶ buttons to choose a programme number or VIDEO terminal. Then press the MENU/OK button.

- For programme numbers with the CHANNEL GUARD function set, the  (CHANNEL GUARD) mark is displayed next to the programme number in the PR LIST.
- The VIDEO terminals are registered after the programme number PR99.

COLOUR SYSTEM button

The colour system is chosen automatically. However, if the picture is not clear or no colour appears, choose the colour system manually.

Press the COLOUR SYSTEM button to choose the appropriate colour system.

AUTO :

This function detects a colour system from the input signal.

- The AUTO mode may not function properly if you have poor signal quality. If the picture is abnormal in the AUTO mode, choose another colour system manually.
- The AUTO mode detects a colour system from the input signal and chooses the appropriate colour system automatically.
- When changing the COLOUR SYSTEM of the SUB-picture, see "Change the colour system of the SUB-picture" on page 15 for details.

Remote control buttons and functions

- For the colour systems in each country or region, see the table "BROADCASTING SYSTEMS" on page 12.

SOUND SYSTEM button

The sound system is chosen automatically. However, if you cannot hear the sound normally even when the picture appears normally, choose the sound system manually.

Press the SOUND SYSTEM button to choose the appropriate sound system.

B/G : B/G system

I : I system

D/K : D/K system

M : M system

- This function does not work in the VIDEO mode.
- For the sound systems in each country or region, see the table "BROADCASTING SYSTEMS" on page 12.

BROADCASTING SYSTEMS

For sound system colour system in your country or region, refer to the table below.

COLOUR SYSTEM

Area	Country or Region	System
Asia, Middle East	Bahrain, Kuwait, Oman, Qatar, United Arab Emirates, Yemen, etc. Indonesia, Malaysia, Singapore, Thailand, India, etc.	PAL
	China, Vietnam, etc	PAL
	Hong Kong, etc	PAL
	Islamic Republic of Iran, Lebanon, Saudi Arabia, etc.	SECAM
Europe	Philippines, Taiwan, Myanmar, etc	NTSC
	Russia, etc	SECAM
	Czech Republic, Poland, etc	PAL
	Germany, Holland, Belgium, etc	PAL
Oceania	UK, etc	PAL
	Australia, New Zealand, etc	PAL
Africa	Republic of South Africa, etc	PAL
	Nigeria, etc	PAL
	Egypt, Morocco, etc	SECAM

SOUND SYSTEM

Area	Country or Region	System
Asia, Middle East	Bahrain, Kuwait, Oman, Qatar, United Arab Emirates, Yemen, etc. Indonesia, Malaysia, Singapore, Thailand, India, etc.	B/G
	China, Vietnam, etc	D/K
	Hong Kong, etc	I
	Islamic Republic of Iran, Lebanon, Saudi Arabia, etc.	B/G
Europe	Philippines, Taiwan, Myanmar, etc	M
	Russia, etc	D/K
	Czech Republic, Poland, etc	D/K
	Germany, Holland, Belgium, etc	B/G
Oceania	UK, etc	I
	Australia, New Zealand, etc	B/G
Africa	Republic of South Africa, etc	I
	Nigeria, etc	B/G
	Egypt, Morocco, etc	B/G

FREEZE button

You can view the Main picture's frozen image as the SUB-picture.

Press the FREEZE button.

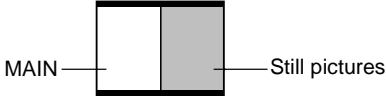

To cancel the FREEZE function :

Press the FREEZE button again.

- You cannot use the FREEZE button when the SUB-picture or the MAIN-picture are displayed on the screen.
- If you press the FREEZE button when receiving the Progressive Video Signal (525P signal), "525P" appears on the screen and the FREEZE function does not operate.

STROBE button

You can view the MAIN-picture as 15 consecutive still images.

Press the STROBE button.

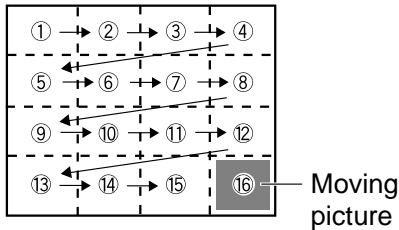

To cancel the STROBE function:

Press the STROBE button to return to the MAIN-picture.

- If signal level of the MAIN-picture is weak, the still images become abnormal.
- You cannot use the STROBE button when the SUB-picture or the MAIN-picture are displayed on the screen.

- If you press the STROBE button when receiving the Progressive Video Signal (525P signal), "525P" appears on the screen and the STROBE function does not operate.

- You cannot change the TINT setting for the still images on the screen even if you are viewing a programme with NTSC colour system.

■ Using the MULTI function

You can display multi-pictures that enable you to easily find a program you want to view.

1 Press the MULTI button.

Press the MULTI button changes the display as follow:

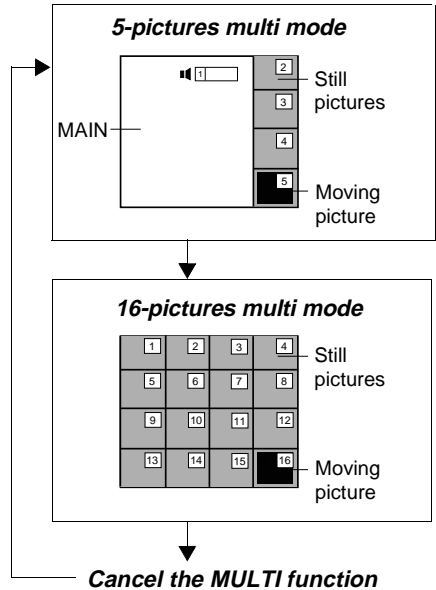

To display next Multi pictures :

Press the NEXT button.

2 Choose the desired picture with the ▲/▼ and ◀/▶ buttons, and then press the MENU/OK button.

The screen switches to the TV channel or VIDEO mode of your choice.

- Any programme numbers to which no TV channel has been registered, or programme numbers to which CHANNEL GUARD has been set is not displayed.
- You cannot perform menu operations such as headphone volume adjustment. Cancel the MULTI function once to perform menu operations.
- If you press the MULTI button when receiving the Progressive Video Signal (525P signal), "525P" appears on the screen and the MULTI function does not operate.
- During the short period that is required for the Multi-pictures display to close no sound comes from the television.

■ Using the PIP function

You can view two pictures (MAIN and SUB) at the same time.

Press the PIP button.

Press the PIP button changes the display as follows:

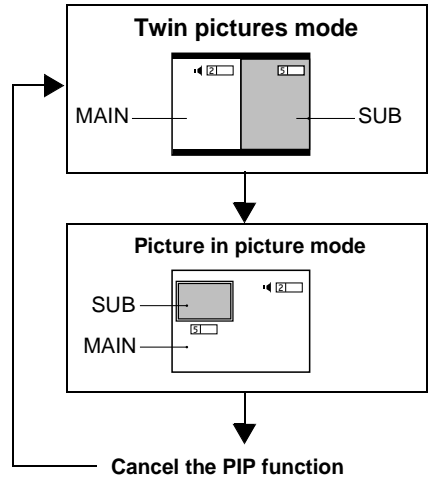

- You cannot view a picture from the same programme number (or the same VIDEO terminal) as both the MAIN-picture and the SUB-picture at the same time.
- If the MAIN-picture signal is poor, then the quality of the SUB-picture may also be poor.
- If the picture standards of both pictures are different, the top and bottom or one of them may be missing.
- The ZOOM function does not operate when viewing pictures using the PIP function.
- The SUB-picture cannot be output from TV.
- If you press the PIP button when receiving the Progressive Video Signal (525P signal), "525P" appears on the screen and the PIP function does not operate.

Choose a TV channel for the SUB-picture

Press the SUB-P +/- button.

Listen to the sound of SUB-picture

You can listen to the sound of SUB-picture on your headphones while listening to the sound of MAIN-picture on the TV speakers. For details, see "HEADPHONE" on page 25.

Change the colour system of the SUB-picture

- 1 While the SUB-picture is displayed, press the MENU/OK button to display the MENU (main manu).
- 2 Press the ▲/▼ and ◀/▶ buttons to choose PICTURE FEATURES, and then press the MENU/OK button.
- 3 Press the ▲/▼ buttons to choose COLOUR SYSTEM, and then press the MENU/OK button.

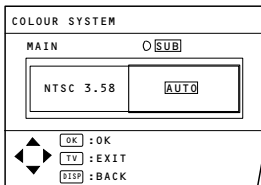

- 4 Press the ◀/▶ buttons to choose SUB, and then press the ▲/▼ buttons to choose the appropriate colour system. Then press the MENU/OK button.

- You cannot change the COLOUR SYSTEM of the SUB-picture using the COLOUR SYSTEM button on the remote control.

POSITION button

You can adjust the position of the SUB-Picture when using the Picture in picture mode.

Press the POSITION button repeatedly.

Each time you press the button, the SUB-Picture moves counterclockwise.

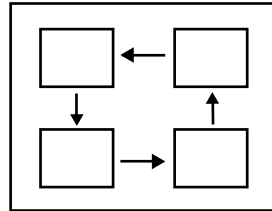

SWAP button

You can replace the MAIN-picture and the SUB-picture with each other.

Press the SWAP button.

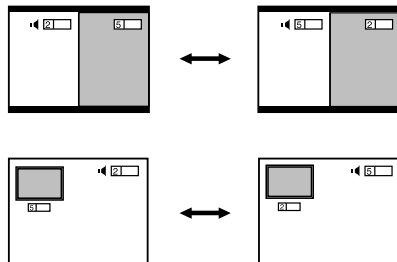

- Do not press the SWAP button while you are recording the TV output on the VCR. If you do, the output signal will change.

■ Viewing a teletext programme

- 1 Choose a TV channel with a teletext broadcast.
- 2 Press the TV/TEXT button.

Pressing the TV/TEXT button changes the mode as follows:

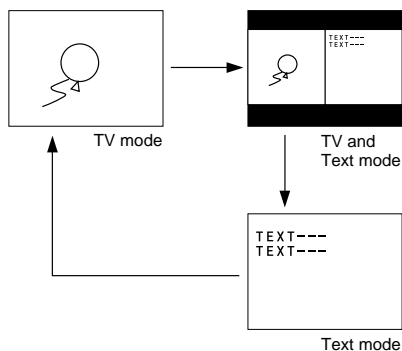

- 3 Choose a teletext page by pressing the CHANNEL-/+ buttons, number buttons or coloured buttons.

To return to the TV mode:

Press the TV/TEXT button or TV/VIDEO button.

- If you have trouble receiving teletext broadcasts, consult your local dealer or the broadcast station.
- In the Text mode, the ZOOM mode is fixed to the REGULAR mode.
- No menu operations are possible when viewing a teletext programme.
- If characters on a teletext programme do not appear properly, change the TELETEXT LANGUAGE setting. For details, see "TELETEXT LANGUAGE" on page 34.

HOLD button

You can hold a teletext page on the screen for as long as you want, even while several other teletext pages are being received.

Press the HOLD button.

The  (hold) are displayed at the top left of the screen.

To cancel the Hold function:

Press the HOLD button again.

REVEAL button

Some teletext pages include hidden text (such as answers to a quiz).

You can display the hidden text.

Each time you press the REVEAL button, text is hidden or revealed.

SIZE button

You can double the height of teletext display.

Press the SIZE button.

INDEX button

You can return to the index page instantly.

Press the INDEX button.

- In the List mode, you can return to the page number displayed in the lower left area of the screen.

CANCEL button

You can search for a teletext page while watching TV.

- 1 Press the number button to enter a page number, or press the coloured button.

The TV searches for a teletext page.

2 Press the CANCEL button.

The TV programme appears. When the TV finds the teletext page, its page number appears in the upper left of the screen.

3 Press the CANCEL button to return to a teletext page when the page number is on the screen.

- You cannot return to the TV mode with the CANCEL button.

SUBPAGE button

Some teletext pages include sub-pages that are automatically displayed. You can hold any sub-page, or view it at any time.

1 Press the SUBPAGE button to operate the Sub-page function.

Sub-page numbers are displayed at the left of the screen.

Colour*	Meaning of sub-page number
Yellow	Currently being displayed.
White	Can be displayed.
Blue or Red	Cannot be displayed and it is not sent.

* : Background color of the sub-page number.

2 Press the CHANNEL +/- buttons to choose a sub-page number.

To cancel the Sub-page function:
Press the SUBPAGE button again.

Using the List mode

You can store the numbers of your favourite teletext pages in memory and call them up quickly using the coloured buttons.

To store the page numbers :

1 Press the MODE button to engage the List mode.

The stored page numbers are displayed at the bottom of the screen.

2 Press a coloured button to choose a position. Then press the number buttons to enter the page number.

3 Press and hold down the STORE button.

The four page numbers blink white to indicate that they are stored in memory.

To call up a stored page :

1 Press the MODE button to engage the List mode.

2 Press a coloured button to which a page has been assigned.

To exit the List mode :

Press the MODE button again.

Using the TV's menu

This TV has a number of functions you can operate using menus.

To fully utilize all your TV's functions, you need to understand the basic menu operating techniques fully.

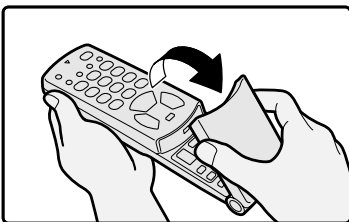
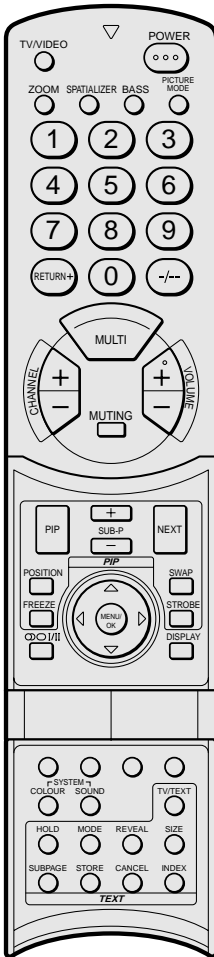

Basic operation

- 1 Press the MENU/OK button to display the MENU (main menu).

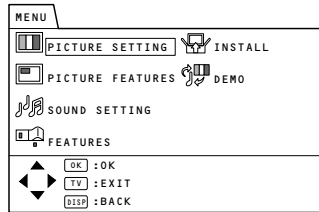

- The display appearing at the bottom of a menu indicates buttons on the remote control you can use when you operate a chosen function.

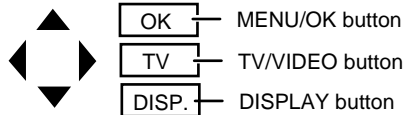

- 2 Press the ▲/▼ and ◀/▶ buttons to choose a menu title, and press the MENU/OK button.

The menu appears.

To return to the previous menu:

Press the DISPLAY button.

To exit a menu instantly:

Press the TV/VIDEO button.

- 3 Press the ▲/▼ buttons to choose a function.

- For details of the functions in the menus, see the following pages.

4 Press the ◀/▶ buttons to choose the setting of that function.

- If you want to operate a function which appears only with its name, follow the descriptions of that function on the following pages.

5 Press the MENU/OK button to complete the setting.

The menu disappears.

- When watching the television with the NTSC system, the menus are displayed at about half of their normal vertical size.

Operation with the buttons on the TV

You can also operate the menus using the buttons on the front panel of the TV.

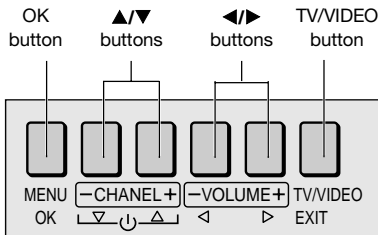

- There is no button on the front panel of the TV that has the function of the DISPLAY or coloured buttons.

PICTURE SETTING menu

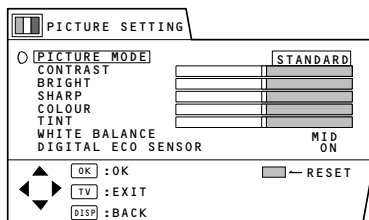

PICTURE MODE

You can choose one of three PICTURE MODEs to adjust the picture settings automatically.

BRIGHT:

Heightens contrast and sharpness.

STANDARD:

Standardizes picture adjustment.

SOFT:

Softens contrast and sharpness.

- You can also operate the PICTURE MODE function with the PICTURE MODE button on the remote control. For details, see "PICTURE MODE button" on page 10.

Adjusting the picture

You can change the picture settings of each picture mode as you like. The picture settings changed are stored in the picture mode.

CONTRAST

You can adjust the picture contrast.

- ◀ : lower
- ▶ : higher

BRIGHT

You can adjust the picture brightness.

- ◀ : darker
- ▶ : brighter

SHARP

You can adjust the picture sharpness.

- ◀ : softer
- ▶ : sharper
- You cannot select the SHARP function when receiving the Progressive Video Signal (525P signal).

COLOUR

You can adjust the picture colour.

- ◀ : lighter
- ▶ : deeper

TINT

You can adjust the picture tint.

- ◀ : reddish
- ▶ : greenish
- You can change the TINT setting (picture tint) only when the colour system is NTSC 3.58 or NTSC 4.43.
- You cannot select the TINT function when receiving the Progressive Video Signal (525P signal).

To return to the default settings in each PICTURE MODE :

Press the blue button. Returns the picture settings in the currently chosen PICTURE MODE mode to the default settings, and stores them in the PICTURE MODE again.

WHITE BALANCE

You can select one of three WHITE BALANCE modes (three tones of white) to adjust the white balance of the picture. Since white is the colour which is used as a reference for all the other colours, changing the WHITE BALANCE mode affects the appearance of all the other colours on the screen.

COOL:

A bluish white. Using this mode when watching bright pictures allows you to enjoy a more vivid and bright picture.

MID:

The normal white colour.

WARM:

A raddish white. Using this mode when watching films allows you to enjoy colours that are characteristic of films.

- You cannot select the WHITE BALANCE function in the Twin pictures mode or the 16:9 mode of the ZOOM function.

■ DIGITAL ECO SENSOR

When you set the DIGITAL ECO SENSOR function to ON, the screen contrast is automatically adjusted to a setting suitable for the brightness of your room. This reduces eye strain for you and the power consumption of the TV.

ON :

This function is turned on.

OFF :

This function is turned off.

DISPLAY :

This function is turned on. Further, clover marks ♣ indicating the brightness of your room are displayed for several seconds each time the brightness changes. The number of clover marks displayed on the screen increases as your room becomes darker.

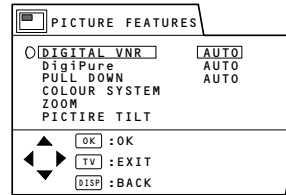
PICTURE FEATURES menu**■ DIGITAL VNR**

The DIGITAL VNR function cuts down the amount of noise in the original picture.

- You cannot select the DIGITAL VNR function when receiving the Progressive Video Signal (525P signal).

AUTO:

The TV will be automatically adjust the level of the DIGITAL VNR effect to match the amount of noise in the picture, giving you the best possible picture.

- If you set the DIGITAL VNR effect too high it can make the picture less sharp. It is recommended to use the AUTO setting if you can.

MAX:

The level of the DIGITAL VNR effect is set to the maximum. If you set the DIGITAL VNR function to AUTO but still notice some noise, change the setting from AUTO to MAX.

- The MAX setting is not suitable for high-quality pictures which contain a lot of noise.

MIN:

The level of the DIGITAL VNR effect is set to the minimum. If you set the DIGITAL VNR function to AUTO but feel that the sharpness of the original picture has not been reproduced fully, change the setting from AUTO to MIN.

- The MIN setting is not suitable for low-quality pictures which contain a lot of noise.

■ DigiPure

The DigiPure function uses the latest in digital technology to give you a natural looking picture. The DigiPure function includes the following two functions.

DigiPure function:

This function helps to create a natural looking picture by eliminating unnecessary edges from high-contrast and crisp images.

Conversely, for images with low-contrast, edges are added to produce a sharper, more detailed picture.

You can choose from the DigiPure function settings of AUTO, MIN and MAX.

Picture motion compensation function:

This function displays fast-moving pictures (for example, the players or ball in a football game) more smoothly and naturally on the screen.

- You cannot select the DigiPure function when receiving the Progressive Video Signal (525P signal).

AUTO:

The TV will automatically adjust the level of the DigiPure effect to match the amount of noise in the picture, giving the best possible picture.

- If you set the DigiPure effect too high on a low-quality picture that contains a lot of noise, this may actually make the noise worse. It is recommended to use the AUTO setting if you can.

MAX:

The level of the DigiPure effect is set to the maximum. If you set the DigiPure function to AUTO but feel that the original picture quality has not been reproduced fully, change the setting from AUTO to MAX.

- The MAX setting is not suitable for low-quality pictures which contain a lot of noise.

MIN:

The level of the DigiPure effect is set to the minimum. When you set the DigiPure function to AUTO and notice some noise, change the setting from AUTO to MIN.

- The MIN setting is not suitable for high-quality pictures which contain very little noise.

OFF:

The DigiPure function is turned off.

■ PULL DOWN

The PULL DOWN function displays a cinema film picture more smoothly and naturally on the screen.

AUTO:

This function is turned on. Normally keep this function set to AUTO.

OFF:

This function is turned off.

- The motion may appear unnatural when viewing images with the NTSC colour system. To make the motion smoother, switch the PULL DOWN function from AUTO to OFF.
- You cannot select this function in the Twin pictures mode or the Picture in picture mode.

■ COLOUR SYSTEM

The colour system is chosen automatically. However, if the picture is not clear or no colour appears, choose the colour system manually.

- 1 Choose **COLOUR SYSTEM**, then press the **MENU/OK** button.

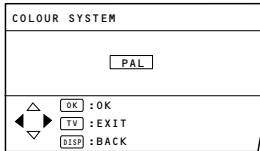

- 2 Press the **◀/▶** buttons to choose the appropriate colour system. Then press the **MENU/OK** button.

- When changing to the **COLOUR SYSTEM** of the **SUB-picture**, see "Change the colour system of the **SUB-picture**" on page 15 for details.
- You can also operate the **COLOUR SYSTEM** function with the **COLOUR SYSTEM** button on the remote control. For details, see "COLOUR SYSTEM button" on page 11.

■ ZOOM

You can change the screen size according to the picture aspect ratio. Choose the optimum one of three **ZOOM** modes.

- 1 Choose **ZOOM**, then press the **MENU/OK** button.

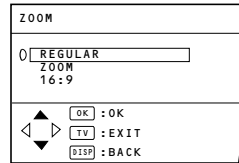

- 2 Press the **▲/▼** buttons to choose a **ZOOM** mode. Then press the **MENU/OK** button.

The picture expands and the chosen **ZOOM** mode is displayed in about 5 seconds.

- You can choose a **ZOOM** mode from **REGULAR**, **ZOOM** or **16:9** modes. For details, see "ZOOM button" on page 9.
- You cannot select the **ZOOM** function when receiving the **Progressive Video Signal (525P signal)**.

■ PICTURE TILT

There are cases where the Earth's magnetic force may make the picture tilt. If this happens, you can correct the picture tilt.

- 1 Choose **PICTURE TILT**, then press the **MENU/OK** button.

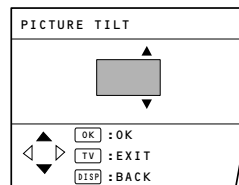

- 2 Press the **▲/▼** buttons until the picture becomes level. Then press the **MENU/OK** button.

SOUND SETTING menu

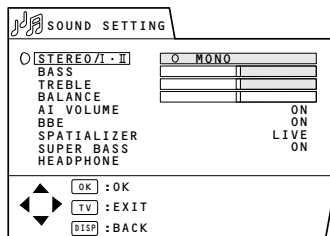

■ STEREO / I·II

When you are viewing a bilingual broadcast programme, you can choose the sound from Bilingual I (sub I) or Bilingual II (sub II). When the stereo broadcasting is received poorly, you can change from stereo to mono sound so that you can hear the broadcast more clearly and easily.

∞ : Stereo sound

○ : mono sound

I : Bilingual I (sub I)

II : Bilingual II (sub II)

MONO: Cancels the Multi Sound function, and the sound becomes monaural.

- The sound mode you can choose differs depending on the TV programme.
- This function does not work in the VIDEO modes.

■ Adjusting the sound

You can adjust the sound to your liking.

BASS

You can adjust the low tone of the sound.

◀ : weaker

▶ : stronger

TREBLE

You can adjust the high tone of the sound.

◀ : weaker

▶ : stronger

BALANCE

You can adjust the volume balance between the left and right speakers.

◀ : turn the left speaker's volume level up.

▶ : turn the right speaker's volume level up.

■ AI VOLUME

You can prevent the sudden increase or decrease of sound that occurs when changing the channel to another channel or switching the VIDEO mode to another VIDEO mode.

ON :

This function is turned on.

OFF :

This function is turned off.

- The AI VOLUME function for TV mode and VIDEO mode can be set separately. For example, you can set it to be OFF in TV mode and ON in VIDEO mode. If you set the AI VOLUME function while viewing images from a VIDEO terminal, the setting is registered as the setting for VIDEO mode.
- The AI VOLUME function may not operate as expected if the sound input level from a broadcast station (or video software) is extremely low.

■ BBE

You can use the BBE function to enjoy easy-to-listen sound that is faithful to the original sound recorded.

ON :

This function is turned on.

OFF :

This function is turned off.

Licensed by BBE Sound, inc. BBE is a registered trademark of BBE Sound, inc.

■ SPATIALIZER

You can enjoy Surround sound with a "live" effect by using the SPATIALIZER function. You can choose one of two SPATIALIZER modes.

- You can choose a SPATIALIZER mode from LIVE, MONO or OFF modes. For details, see " SPATIALIZER button " on page 9.

The SPATIALIZER is manufactured under license from Desper Products, Inc.

■ SUPER BASS

You can enjoy a powerful bass sound by using the Super Bass (Super Bass Reflex) function.

ON :

This function is turned on.

OFF :

This function is turned off.

■ HEADPHONE

This function enables you to output the TV's sound from your headphones.

- 1 Choose HEADPHONE, then press MENU/OK button.

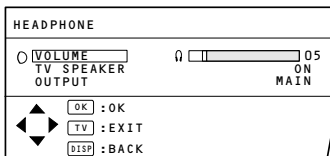

- 2 Use the ▲/▼ button to select, and the ◀/▶ button to set the HEADPHONE function. Then press the MENU/OK button.

VOLUME :

You can adjust the volume of the sound output from your headphones.

TV SPEAKER:

When this function is on, the TV's speaker does not shut off the sound even if headphones are connected.

If you set this function to off, the TV's speaker does not output the sound when the headphones are connected.

OUTPUT:

You can choose the sound from the MAIN-picture(MAIN) or the SUB-picture(SUB) when using the headphones.

- The TV's speaker does not put out the sound from the SUB-picture.
- The sound of the SUB-picture is mono only. You cannot use the STEREO/II function for the sound of the SUB-picture.

FEATURES menu

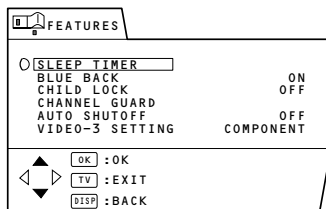

■ SLEEP TIMER

You can set the TV to automatically turn off after a set time.

- 1 Choose **SLEEP TIMER**, then press the **MENU/OK** button.

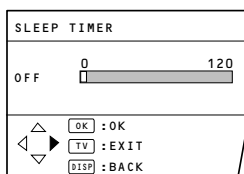

- 2 Press the **◀/▶** buttons to set the period of time.

The TV begins count down from the set time.

- You can set the period of time a maximum of 120 minutes (2 hours) in 10 minute steps.

To cancel this function:

Press the **◀** button to set a period of time to "OFF".

- 3 Press the **MENU/OK** button to complete the setting.

The menu disappears.

- One minute before this function turns off the TV, "GOOD NIGHT!" appears.
- This function cannot be used to turn off the TV's main power.
- When this function is on, you can display the **SLEEP TIMER** menu again to confirm or change the remaining time.

■ BLUE BACK

You can set the TV to automatically change to a blue screen and mute the sound if the signal is weak or absent, or when there is no input from an external device.

ON :

This function is turned on.

OFF:

This function is turned off.

■ CHILD LOCK

You can disable the front control buttons of the TV. When this function is set to ON, the TV can be operated only by using the remote control.

Use this function to prevent children from operating the TV at their own discretion (without parent consent).

ON :

This function is turned on.

OFF:

This function is turned off.

■ CHANNEL GUARD

When there is a TV channel you do not want your children to watch, you can lock out the channel. Even when a child chooses a programme number for a locked out channel the screen will change to blue and display  so the channel cannot be viewed.

To set this function

- 1 Choose **CHANNEL GUARD**, then press the number **0** (AV) button.

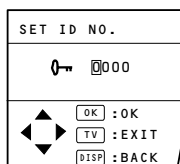

2 Set the ID number you want.

To choose a number:

Press the ▲/▼ buttons.

To move a cursor:

Press the ◀/▶ buttons.

3 Press the MENU/OK button.

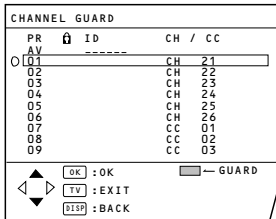

4 Press the ▲/▼ buttons to choose a TV channel.

- The TV shows the TV programme which the chosen TV channel is now broadcasting.

5 Press the blue button to set this function to the TV channel.

🔒 (CHANNEL GUARD) appears and the TV channel is locked.

To cancel this function:

Press the blue button again.

🔒 (CHANNEL GUARD) disappears and the lock is released.

6 Press the MENU/OK button to complete the setting.

The menu disappears.

To view a locked TV channel

1 Choose a programme number in which a TV channel locked with the number buttons or PR LIST.

The screen changes to blue and the 🔒 (CHANNEL GUARD) appears.

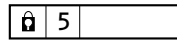

- You cannot choose a locked TV channel with the ▲/▼ buttons.

2 Press the DISPLAY button to display " ID NO. " (ID number input screen).

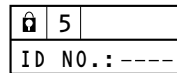

3 Press the number buttons to enter the ID number.

The lock is temporarily released so you can view the TV channel.

If you have forgotten the ID number:

Perform step 1 of "To set this function".

After confirming the ID number, press the TV/VIDEO button to exit the menu.

- When you would like to cancel the CHANNEL GUARD function, you must perform the operation " To set this function" again.

■ **AUTO SHUTOFF**

You can set your TV to turn off if no signal are received for about 15 minutes or longer after the end of a broadcast.

ON :

This function is turned on.

OFF :

This function is turned off.

- The AUTO SHUTOFF function does not turn off the TV's main power.
- The AUTO SHUTOFF will not work for a VIDEO mode.

■ **VIDEO-3 SETTING**

Set the VIDEO-3 SETTING correctly according to the video signal input from the external device connected to the VIDEO-3 terminal. If this setting is incorrect, images will not be displayed.

VIDEO :

If a normal video signal (composite video signal) is input.

COMPONENT :

If a Component video signal (Y/C_B/C_R signals) is input.

- For detailed connecting methods, see " Additional preparation " on page 36.
- This Television is compatible with the Progressive Video Signal (525P signal) only when the component video signal is input.

INSTALL menu

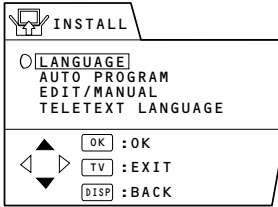

■ LANGUAGE

You can choose the language you want to use for the on-screen display from the language list in a menu.

- 1 Choose LANGUAGE, then press the MENU/OK button.

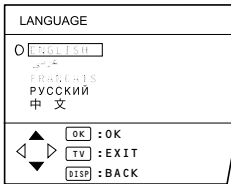

- 2 Press the ▲/▼ buttons to choose a language.
- 3 Press the MENU/OK button to complete the setting.

The menu disappears.

■ AUTO PROGRAM

You can automatically register the TV channels which can be received well at your residence in the TV's programme numbers by performing the following.

- 1 Choose AUTO PROGRAM, then press the MENU/OK button.

The AUTO PROGRAM function starts. The TV channels you receive are automatically stored in the programme numbers list.

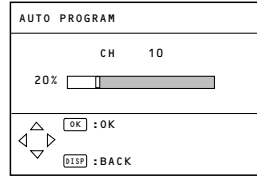

- To cancel the AUTO PROGRAM function, press the DISPLAY button.

- 2 After the TV channels have been stored in the programme number list, the EDIT menu appears.

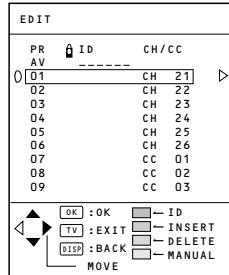

- You can proceed to edit the programme numbers list using the EDIT/MANUAL function. For details, see "EDIT/MANUAL" on page 30.
- If a TV channel you want to view is not stored in the programme numbers list, you can register it using the MANUAL function. For details, see "EDIT/MANUAL" on page 30.
- The AUTO PROGRAM function does not store a TV channel to the programme number 0 (AV).
- If you do not need to use the EDIT/MANUAL function, press the MENU/OK button to exit from the EDIT menu.

■ EDIT/MANUAL

The EDIT/MANUAL functions are divided into two types:

editing of the current programme numbers (EDIT functions) and manual registration of a TV channel you want to view to the programme number (MANUAL function).

CAUTION

- Using the MOVE,DELETE or INSERT function rewrites the current programme numbers list. Resultingly, the programme number of some of the TV channels will change.
- When a TV channel which has been locked out using the CHANNEL GUARD function, using the MANUAL function for that TV channel cancels the CHANNEL GUARD function.
- When a TV channel has already been registered in PR 99, using the INSERT function deletes the TV channel.

- 1 Choose EDIT/MANUAL, then press the MENU/OK button.

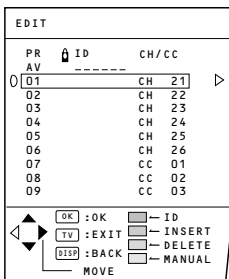

- 2 Follow the operation description of a function you want to use and operate the function.

MOVE :

This function changes a programme number of a TV channel.

ID :

This function registers a Channel name (ID) to a TV channel.

INSERT:

This function adds a new TV channel in the current programme numbers list by using the CH/CC number.

DELETE :

This function deletes a unnecessary TV Channel.

MANUAL :

This function manually registers a new TV channel in a programme number.

- 3 Press the MENU/OK button to complete the setting.

- For programme number PR 0, "AV" appears in the programme numbers list.

FUNCTIONS

MOVE

- 1 Press the ▲/▼ buttons to choose a TV channel.
- 2 Press the ► button to start the MOVE function.

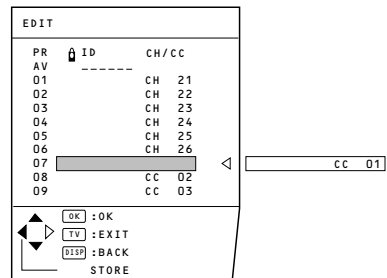

- 3 Press the ▲/▼ buttons to choose a new programme number.

To cancel the MOVE function:
Press the DISPLAY button.

- 4 Press the ◀ button to change the programme number of a TV channel to a new programme number.

ID

- 1 Press the ▲/▼ buttons to choose a TV channel.
- 2 Press the red button to start the ID function.
- 3 Enter a channel name (ID). Press the ▲/▼ buttons to choose a character. press the ◀/▶ buttons to move the cursor.

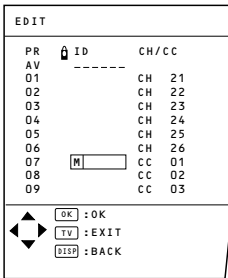

To cancel the ID function:
Press the DISPLAY button.

- 4 Press the MENU/OK button to register a channel name to a TV channel.

DELETE

- 1 Press the ▲/▼ buttons to choose a TV channel.
- 2 Press the yellow button to delete the TV channel.

The TV channel is deleted from the programme numbers list.

MANUAL

- 1 Press the ▲/▼ buttons to choose a programme number to which you want to register a new TV channel.
- 2 Press the blue button to activate the MANUAL function.

At the right side following the CH/CC number, the SYSTEM (sound system) of the TV channel appears.

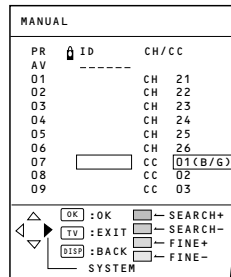

To cancel the MANUAL function:
Press the DISPLAY button.

- 3 Press the ▶ button to choose the system (sound system) for a TV channel you want to register.

- For the sound systems in each country or region, see the table "BROADCASTING SYSTEMS" on page 12.

- 4 Press the green or red button to search for a TV channel.

Scanning stops when the TV finds a TV channel. Then the TV channel is displayed.

- 5 Press the green or red button repeatedly until the TV channel you want appears.

If the TV channel reception is poor:
Press the blue or yellow button to finetune the TV channel.

If you cannot hear the normal sound even when the picture of the TV channel appears normally:

The SYSTEM setting is wrong. Press the ▶ button and choose a SYSTEM that has normal sound.

- 6 Press the MENU/OK button and register the TV channel to a programme number.

The normal EDIT menu is resumed.

INSERT

PREPARATION

- Find the CH/CC number corresponding to the channel number of the TV channel from the on page 33.
- 1 Press the ▲/▼ buttons to choose a programme number for which you will register a new TV channel.
 - 2 Press the green button to start the INSERT function.

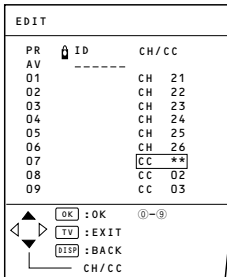

- 3 Press the ▲/▼ buttons to choose "CC" or "CH" according to the CH/CC number of the TV channel.

To cancel the INSERT function:
Press the DISPLAY button.

- 4 Press the Number buttons to enter the remaining CH/CC number.

The TV shifts to registration mode.
When the registration is completed, the picture of the TV channel appears on the screen.

- The CH/CC number is a number indicating the broadcast frequency to the TV. If the TV cannot detect the TV channel corresponding to the broadcast frequency indicated by the CH/CC number, a picture in the no-signal state appears.

CH/CC number

When you want to use the INSERT function on page 32, find the CH/CC number corresponding to the Channel number of the TV channel from this table.

US : The US channel numbers are the channel numbers used in the United States, Philippines, etc.

CCIR: The CCIR channel numbers are the channel numbers used in the Middle East, Southeast Asia ,etc.

OIRT: The OIRT channel numbers are the channel numbers used in Eastern Europe,Russia, Vietnam, etc.

AUSTRALIA: The AUSTRALIA channel numbers are the channel numbers used in Australia, etc.

Channel				
CH	US	CCIR	OIRT	AUSTRALIA
CH 02	US-2	E2	R1	AU-0
CH 03	US-3	E3		AU-1
CH 04	US-4	E4	R2	AU-2
CH 05	US-5	E5	R6	AU-6
CH 06	US-6	E6	R7	AU-7
CH 07	US-7	E7	R8	AU-8
CH 08	US-8	E8	R9	AU-9
CH 09	US-9	E9		
CH 10	US-10	E10	R10	AU-10
CH 11	US-11	E11	R11	AU-11
CH 12	US-12	E12	R12	
CH 13	US-13			
CH 14	US-14			
CH 15	US-15			
CH 16	US-16			
CH 17	US-17			
CH 18	US-18			
CH 19	US-19			
CH 20	US-20			
CH 21	US-21	E21		
CH 22	US-22	E22		
CH 23	US-23	E23		
CH 24	US-24	E24		
CH 25	US-25	E25		
CH 26	US-26	E26		
CH 27	US-27	E27		
CH 28	US-28	E28		
CH 29	US-29	E29		
CH 30	US-30	E30		
CH 31	US-31	E31		
CH 32	US-32	E32		
CH 33	US-33	E33		
CH 34	US-34	E34		
CH 35	US-35	E35		
CH 36	US-36	E36		
CH 37	US-37	E37		
CH 38	US-38	E38		
CH 39	US-39	E39		
CH 40	US-40	E40		
CH 41	US-41	E41		
CH 42	US-42	E42		
CH 43	US-43	E43		
CH 44	US-44	E44		
CH 45	US-45	E45		
CH 46	US-46	E46		
CH 47	US-47	E47		
CH 48	US-48	E48		
CH 49	US-49	E49		
CH 50	US-50	E50		
CH 51	US-51	E51		
CH 52	US-52	E52		
CH 53	US-53	E53		
CH 54	US-54	E54		
CH 55	US-55	E55		
CH 56	US-56	E56		
CH 57	US-57	E57		
CH 58	US-58	E58		
CH 59	US-59	E59		
CH 60	US-60	E60		
CH 61	US-61	E61		
CH 62	US-62	E62		
CH 63	US-63	E63		
CH 64	US-64	E64		
CH 65	US-65	E65		
CH 66	US-66	E66		
CH 67	US-67	E67		
CH 68	US-68	E68		
CH 69	US-69	E69		
CH 70				

Channel				
CC	US	CCIR	OIRT	AUSTRALIA
CC 01		S-1		AU-5
CC 02		S-2		
CC 03		S-3		
CC 04		S-4		
CC 05		S-5		
CC 06		S-6		AU-5A
CC 07		S-7		
CC 08		S-8		
CC 09		S-9		
CC 10		S-10		
CC 11		S-11		
CC 12		S-12		
CC 13		S-13		
CC 14	A	S-14		
CC 15	B	S-15		
CC 16	C	S-16		
CC 17	D	S-17		
CC 18	E	S-18		
CC 19	F	S-19		
CC 20	G	S-20		
CC 21	H	S-21		
CC 22	I	S-22		
CC 23	J	S-23		
CC 24	K	S-24		
CC 25	L	S-25		
CC 26	M	S-26		
CC 27	N	S-27		
CC 28	O	S-28		
CC 29	P	S-29		
CC 30	Q	S-30		
CC 31	R	S-31		
CC 32	S	S-32		
CC 33	T	S-33		
CC 34	U	S-34		
CC 35	V	S-35		
CC 36	W	S-36		
CC 37	W+1	S-37		
CC 38	W+2	S-38		
CC 39	W+3	S-39		
CC 40	W+4	S-40		
CC 41	W+5	S-41		
CC 42	W+6			
CC 43	W+7			
CC 44	W+8			
CC 45	W+9			
CC 46	W+10			
CC 47	W+11			
CC 48	W+12			
CC 49	W+13			
CC 50	W+14			
CC 51	W+15			
CC 52	W+16			
CC 53	W+17			
CC 54	W+18			
CC 55	W+19			
CC 56	W+20			
CC 57	W+21			
CC 58	W+22			
CC 59	W+23			
CC 60	W+24			
CC 61	W+25			
CC 62	W+26			
CC 63	W+27			
CC 64	W+28			
CC 75		X		
CC 76		Y	R3	
CC 77		Z	R4	AU-3
CC 78		Z+1	R5	
CC 79		Z+2		AU-4
CC 95	A-5			
CC 96	A-4			
CC 97	A-3			
CC 98	A-2			
CC 99	A-1			

■ TELETEXT LANGUAGE

There are 4 types of teletext language groups. Set the teletext language group that corresponds to the language of the teletext program that you want to watch.

- Languages that are not included in the teletext language group that you select, the sub-titles of the teletext program will not be displayed properly.

- 1 Choose TELETEXT LANGUAGE, then press the MENU/OK button.

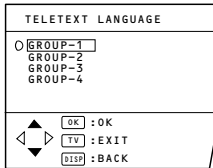

- 2 Press the ▲/▼ buttons to choose a group.

Group	Languages
GROUP-1	Turkish, Hungarian, English, German, French, Italian, Spanish, Portuguese, Greek, Swedish, Finnish
GROUP-2	Polish, Serbian, Croatian, Slovenian, Czech, Slovak, Rumanian, Hungarian, German, French, Italian, Swedish, Finnish
GROUP-3	Russian, Bulgarian, Lettish, Lithuanian, Estonian, Ukrainan, Serbian, Croatian, Slovenian, Czech, Slovak, English, German
GROUP-4	Arabic, Czech, Slovak, Hungarian, English, German, French, Italian, Spanish, Portuguese, Swedish, Finnish

- 3 Press the MENU/OK button to complete the setting.

The menu disappears.

DEMO menu

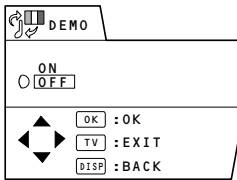

The DEMO function automatically demonstrates some of the TV function.

When the DEMO function is set to ON:

Each time the TV is turned on, the demonstration starts automatically.

If you do not want that to happen, set the DEMO function to OFF.

- 1 Press the ▲/▼ buttons to choose ON.

To cancel the DEMO function, choose off.

- 2 Press the MENU/OK button to complete the settings.

The DEMO function is set to ON, and the demonstration will start.

To stop the demonstration:

Press one of the buttons on the remote control.

Additional preparation

■ Connecting the external devices

Connect the devices to the TV, paying attention to the following connection diagram.

Before connecting anything:

- Read the manuals provided with the devices. Depending on the devices, the connection method may differ from the figure. In addition, the device settings may be changed depending on the connection method to secure proper operation.
- Turn off all the devices including the TV.
- The "Specifications" on page 43 contains the details of the VIDEO terminals. If you are connecting a device not listed in the following connection diagram, see the "Specifications" to choose the best VIDEO terminal.
- Note that connecting cables are not supplied.
- When connecting devices that are supported by AV COMPU LINK, see "Connecting AV COMPU LINK Supported Devices" on page 38.

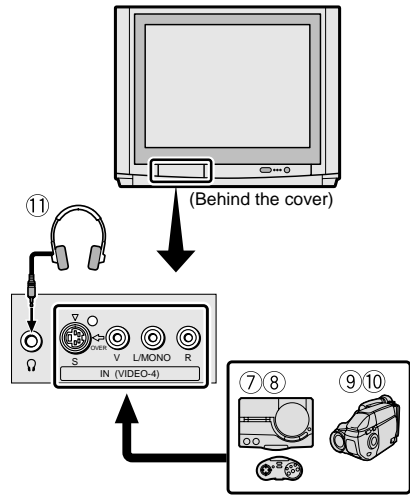

- ① VCR (composite signal)
- ② VCR (S-VIDEO signal; Y/C)
- ③ VCR for recording (composite signal)
- ④ DVD player (composite signal)
- ⑤ DVD player (S-VIDEO signal; Y/C)
- ⑥ DVD player (component video signals; Y/C_B/C_R)
- ⑦ TV game (composite signal)
- ⑧ TV game (S-VIDEO signal; Y/C)
- ⑨ Camcorder (composite signal)
- ⑩ Camcorder (S-VIDEO signal; Y/C)
- ⑪ Headphones

Ⓐ AV COMPU LINK cable

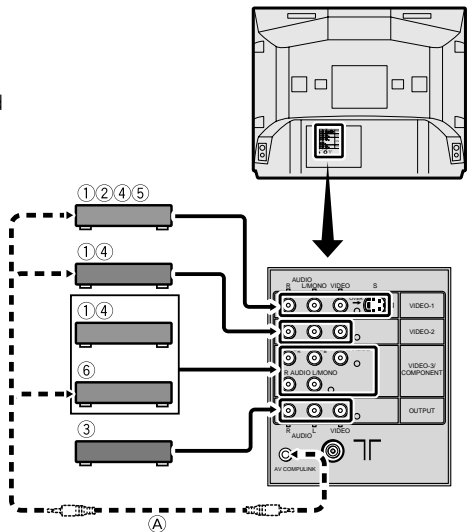

Connecting methods

- 1 Connect the TV's VIDEO jack and the device's VIDEO OUT (video output) jack with a video cable.

If connecting a device to the TV with an S-VIDEO cable :

Connect the VCR's S-VIDEO OUT (S-VIDEO output) connector and the TV's "S" (S-VIDEO) connector with an S-VIDEO cable, instead of connecting with a video cable.

Note that the connection with a video cable will be ignored in case you connect a VCR to the TV with both video cable and S-VIDEO cable.

If connecting a DVD player to the TV with a component video cable:

Connect three jacks (Y/VIDEO, C_B and C_R) in the VIDEO-3 terminal and the DVD player's COMPONENT (component video output) jacks with a component video cables, instead of connection with a video cable. Then set the VIDEO-3 SETTING to COMPONENT, according to "VIDEO-3 SETTING" on page 28.

- This Television is compatible with the Progressive video signal (525P signal). (When the component video signal is input.)

If you have a DVD player that outputs Progressive video signals (525P) as a component video signal, then by attaching the device to the television with a component video cable you can see the actual images that are recorded on a DVD disc as an original image source.

If connecting a device to the VIDEO-3/COMPONENT terminal with a video cable:

Connect the TV's Y/VIDEO jack and the device's VIDEO OUT (video output) jack with a video cables.

Then set the VIDEO-3 SETTING to VIDEO according to "VIDEO-3 SETTING" on page 28.

- In the VIDEO-4 terminal, the VIDEO jack is indicated by "V".

- 2 Connect the TV's AUDIO jacks (L/MONO and R) and the device's AUDIO OUT (audio L/R output) jacks with an audio cable.

If the device's sound output is in mono :

Connect the device's AUDIO OUT jack and the TV's L/MONO jack with an audio cable.

Connecting devices to the OUTPUT terminal

The signals of the images and sound you are currently viewing with this TV are output through the OUTPUT terminal. By connecting a VCR to the OUTPUT terminal, you can record the currently shown image and sound to that VCR. To do this, connect the VCR and OUTPUT terminal following the steps below.

- 1 Connect the VIDEO jack in the OUTPUT terminal and the VCR's VIDEO IN (video input) jack with a video cable.
- 2 Connect the AUDIO jacks (L and R) in the OUTPUT terminal and the VCR's AUDIO IN (audio L/R input) jacks with an audio cable.

- When you turn off the TV, the signals from the OUTPUT terminal are also turned off.
- The component signals input from the VIDEO-3/COMPONENT terminal cannot be output through the OUTPUT terminal.

Connecting Headphones

Connect the headphones with a stereo mini jack (of 3.5 mm in diameter) to the Headphone jack at the TV front panel.

■ Connecting AV COMPU LINK Supported Devices

AV COMPU LINK remote control system is a system in which related devices are automatically controlled when you operate one device.

If you apply this system to the TV, you can have the TV automatically perform the required operations by operating one external device. You don't have to use the TV's remote control to turn on the TV or change the VIDEO modes.

Examples of the AV COMPU LINK remote control system operations

Simply by pressing the PLAY button on a VCR or a DVD player, you can view images from the device.

Simply by inserting a pre-recorded tape (a tape with the record safety tab removed) to a VCR, you can view the tape.

Simply by operating the AV Control Receiver, you can have the TV turned on/off (in standby mode) or the VIDEO mode changed correctly.

- The performance of the AV COMPU LINK remote control system varies depending on the connected device. See the device's instruction manual.
- When you select "TV SOUND" as the input source with the AV Control Receiver, there are cases where the TV's MUTING function automatically operates and the sound from the TV's speakers is muted.
In such cases, press the VOLUME-/+ buttons or the MUTING button on the TV's remote control to cancel the MUTING function. You can regain the sound from the TV's speakers.

Conditions to use the AV COMPU LINK remote control system

- A device equipped with an AV COMPU LINK terminal is required.
- You must connect the TV and the device with an AV COMPU LINK cable.
AV COMPU LINK cable is not supplied with this TV. If an AV COMPU LINK cable is unavailable, connect them with a cable with dia. 3.5 mm (mono) male plugs at both ends.
- You must connect the device to an appropriate VIDEO terminal and set it up correctly. Otherwise the AV COMPU LINK remote control system will not function correctly. For details, see "Setting up the AV COMPU LINK remote control system".
- The TV must be in standby mode (the POWER lamp lighting red). If the TV's Main power is off (the POWER lamp off), the AV COMPU LINK remote control system does not function.

Setting up the AV COMPU LINK remote control system

CAUTION:

- With some devices, the setup method differs from the ones explained here. Be sure to read the device's instruction manual thoroughly before setting it up.

- 1 Connect the device to the TV's VIDEO-1 or VIDEO-2 terminal.

If you want to connect a DVD player to the TV with a component video cable :

Connect the DVD player to the TV's VIDEO-3 terminal.

- For detailed connecting instructions, see "Connecting the external devices" on page 36.

- 2 Connect the TV's AV COMPU LINK terminal and the device's AV COMPU LINK terminal with an AV COMPU LINK cable.
- 3 Change the device's setting according to the VIDEO terminal it is connected to.

If a VCR is connected to the VIDEO-1 terminal :

Set the VCR's remote control code to A code.

If a DVD player is connected to the VIDEO-1 terminal:

Set the DVD player's AV COMPULINK MODE to DVD2.

If a VCR is connected to the VIDEO-2 terminal:

Set the VCR's remote control code to B code.

If a DVD player is connected to the VIDEO-2 terminal:

Set the DVD player's AV COMPULINK MODE to DVD3.

If a DVD player is connected to the VIDEO-3 terminal with a component video cable:

Set the DVD player's AV COMPULINK MODE to DVD1.

- For instructions on how to change the device's setting, refer to the device's instruction manual.
- If the device you are connecting has neither the remote control code nor the AV COMPULINK MODE, then connect it to the TV's VIDEO-1 terminal.

Troubleshooting

If a problem arises while you are using the TV, please read this "Troubleshooting" well before you request having the TV repaired. You may be able to fix it easily by yourself. For example, if the AC plug is disconnected from the AC outlet, or the TV aerial has problems, you may think there is a problem with the TV itself.

Important:

- This Troubleshooting guide only covers problems whose cause are not easy to determine. If a question arise when you are operating a function, read the page(s) corresponding to the operation of the function well, not this Troubleshooting guide.
- After you have followed the Troubleshooting description or the operating description of the functions concerned without any success, remove the AC plug from the AC outlet and re - quest a repair of your TV. Do not attempt to repair the TV by yourself or remove the rearcover of the TV.

■ If you cannot turn on the TV

- Is the AC plug connected to the AC outlet?
- Is the POWER lamp lit? If not, press the Main power button.

■ No picture/No sound

- Have you chosen a TV channel whose reception is extremely bad? In this case, the BLUE BACK function will be activated, the entire screen becomes blue, and the sound is muted. In spite of this, if you want to view the TV channel, follow the description "BLUE BACK" on page 26 to try to change the BLUE BACK function setting to OFF.
- Are your SOUND SYSTEM settings for the TV channels correct?
Forrow the description "SOUND SYSTEM Button" on page 12 to try to solve the trouble.

■ Poor picture

- If noise totally obscures the picture (snow), the aerial or aerial cable may have trouble. Check the following to try to solve the trouble :

Has the TV and aerial been connected properly?

Has the aerial cable been damaged?
Is the aerial pointed to the right direction?

Is the aerial itself faulty?

- If the TV or aerial receives interference from the other devices, stripes or noise may appear in the picture. Move such device as an amplifier, personal computer, or a hair drier that can cause interference away from your TV, or try changing its location. If the aerial suffers interference from a radio tower or high-voltage wire, please contact your local dealer.
- If the TV receives interferences from signal reflecting from mountains or building, double-pictures(ghosting) will occur.
Try to change the aerial's direction or replace the antenna with the one with better directionality.
- Are your COLOUR SYSTEM settings for the TV channels correct? Follow the description "COLOUR SYSTEM button" on page 11 to try to solve the trouble.
- Has COLOUR or BRIGHT been controlled properly? Follow the description "Adjusting the picture" on page 20 to try to adjust them properly.
- Videotaping teletext is not recommended because it may not record correctly.

- When a white and bright still image (such as a white dress) is displayed on the screen, the white part may look as if it were coloured.

It is a phenomenon unavoidable due to the nature of the picture tube itself, and not due to a TV failure.

When the picture disappears from the screen, the unnatural colours will also disappear.

- When viewing images from commercially available video software products, or videos from videotapes which have been recorded improperly, the top of the image may be distorted.

This is due to the condition of the video signal, and not because of malfunction.

■ Poor sound

- Have you adjusted BASS or TREBLE properly? If not, follow the description "Adjusting the Sound" on page 24 to try to adjust them properly.
- When the TV channel reception is poor, it can be hard to hear the stereo or bilingual sound. In this case, follow the description "STEREO / I • II" on page 24 to hear the sound more easily by changing it to a mono sound.

■ Operation disabled

- Have the batteries of the remote control become exhausted?
Follow the description "Putting the Batteries into the Remote Control" on page 4 and replace them with new batteries to try to solve the problem.
- Have you attempted to use the remote control at the sides or rear of the TV or at a location more than seven meters apart from the TV location? Operate the remote control in the front of your TV or a location less than seven meters from your TV to try to solve the problem.

- When you are viewing a teletext programme, you cannot operate the menus. Press the TV/VIDEO button to return the teletext programme to the ordinary TV programme to try operating the menus.

- Is the CHILD LOCK function set to ON? If the CHILD LOCK function is set to ON, you cannot operate the TV with the front control buttons of the TV. Follow the description "CHILD LOCK" on page 26 to try to set the CHILD LOCK function to OFF.

- If the TV operation becomes disabled suddenly, press the Main power button on the TV and turn off the main power. Try to press the Main power button again to turn on the main power. If the TV returns to a normal state, it is not a failure.

- The following functions do not operate when receiving Progressive Video Signal (525P signal);
Remote control function:
ZOOM, PIP, MULTI, FREEZE and STROBE BUTTON
MENU function:
SHARP, TINT, DIGITAL VNR, Digipure and ZOOM

■ Other concerns

- When the SLEEP TIMER function or AUTO SHUTOFF function operates, the TV is automatically turned off. If the TV is turned off suddenly, try to press the POWER button to turn on the TV once again. At this time, if the TV resumes a normal state, there is no problem.
- If you do not want sound emitted from the TV's speakers when using headphones, change the TV SPEAKER setting in the HEADPHONE menu to OFF. For details, see "HEADPHONE" on page 25.

Troubleshooting

- If you bring a magnetised device such as a speaker near to your TV, a picture may be warped or unnatural colours appear at the corners of the screen. In this case, keep the device apart from your TV. If the speaker causes such phenomena, use the magnetic-shielded speaker instead.
- A picture may be tilted due to the influence of the earth's magnetism. In this case, use the "PICTURE TILT" on page 23 to complete the tilt.
- It takes a short period of time from the time an operation such as changing channels is performed until an image is displayed. This is not a malfunction. This is the time required for the image to stabilize before it can be displayed.
- The TV may emit a crackling sound due to a sudden change in temperature. It does not matter if a picture or sound does not show any abnormality. If you hear crackling sounds frequently while you are viewing the TV, other causes may be assumed.
For precautionary purposes, request your service technician to inspect it.
- Touching the screen may cause you feel a slight electric shock due to its static electricity.
It is an unavoidable phenomenon due to the construction of the picture tube. It is not a problem with the TV.
You can rest assured that this static discharge does not have harmful influence over the human body.

Specifications

Broadcasting systems	B, G, I, D, K, K1, M
Colour systems	PAL, SECAM, NTSC3.58/4.43MHz
Channels and frequencies	VHF low channel (VL) =46.25 to 168.25 MHz VHF high channel (VH) =175.25 to 463.25 MHz UHF channel (U) =471.25 to 863.25 MHz <ul style="list-style-type: none"> ■ Receives cable channels in mid band (X to Z+2, S1 to S10), super band (S11 to S20) and hyper band (S21 to S41).
Sound-multiplex systems	A2 (B/G), NICAM (B/G, I, D/K) system
Teletext systems	FLOF(Fastext), WST(World Standard Text)
Langauges displayed by teletext	Please see the table in the description "TELETEXT LANGUAGE" on page 34
Power requirements	AC 110 to 240V, 50/60Hz
Audio output	Rated Power output: 20W + 20W
VIDEO-1 terminal	RCA connector X 3, S-VIDEO connector X 1 <ul style="list-style-type: none"> • Video input, S-VIDEO (Y/C) input and Audio L/R inputs are available.
VIDEO-2 terminal	RCA connector X 3 <ul style="list-style-type: none"> • Video input and Audio L/R inputs are available.
VIDEO-3/COMPONENT terminal	RCA connector X 5 <ul style="list-style-type: none"> • Video input/Component video (Y/C_B/C_R) input and Audio L/R inputs are available. • Progressive video signal(525P signal) input is available.
VIDEO-4 terminal	RCA connector X 3, S-VIDEO connector X 1 <ul style="list-style-type: none"> • Video input, S-VIDEO (Y/C) input and Audio L/R inputs are available.
OUTPUT terminal	RCA connector X 3 <ul style="list-style-type: none"> • Video output and Audio L/R outputs are available.
Headphone jack	Stereo mini-jack (3.5 mm in diameter)
Accessories	Remote control unit X 1 (RM-C214) AA/R6 dry cell battery X 2
Speakers	HV-34LPZ : 12cm round X 2, 3.5cm round X 2 HV-29LPZ : 10cm round X 2, 3.5cm round X 2
Power consumption	HV-34LPZ : Maximum 255W Average 170W HV-29LPZ : Maximum 254W Average 170W
Screen size (measured diagonally)	HV-34LPZ : Picture tube 87cm Visible area 80cm HV-29LPZ : Picture tube 73cm Visible area 68cm
Dimensions(W X H X D)	HV-34LPZ : 898mm X 728mm X 579mm HV-29LPZ : 732mm X 588mm X 518mm
Weight	HV-34LPZ : 75kg HV-29LPZ : 48kg

Design and specifications subject to change without notice.

Pictures displayed on the screen using this TV's ZOOM functions should not be shown for any commercial or demonstration purpose in public places (cafes,hotels, etc.) without the consent of the owners of copyright of the original picture sources, as this constitutes an infringement of copyright.

JVC
VICTOR COMPANY OF JAPAN, LIMITED

JVC



ЦВЕТНОЙ ТЕЛЕВИЗОР

NV-34LPZ NV-29LPZ



InteriArt
Premiere

DigiPure

100Hz & PROGRESSIVE SCAN

Содержание

Настройка телевизора	3
Кнопки и функции телевизора	6
Кнопки и функции пульта дистанционного управления	8
Как пользоваться меню телевизора	18
Основные операции	18
Меню ПАРАМЕТРЫ ИЗОБРАЖЕНИЯ	20
Меню СВОЙСТВА ИЗОБРАЖЕНИЯ	21
Меню ПРЕДУСТАНОВКИ ЗУКА	24
Меню СВОЙСТВА	26
Меню НАСТРОЙКИ	29
Меню ДЕМО	35
Дополнительная подготовка	36
Устранение неисправностей	40
Технические данные	43

ИНСТРУКЦИЯ ПО ЭКСПЛУАТАЦИИ



Благодарим за покупку цветного телевизора JVC.

Перед началом использования, пожалуйста, внимательно прочтите это руководство, чтобы понять как пользоваться Вашим новым телевизором.

ОСТОРОЖНО:

**ВО ИЗБЕЖАНИЕ ПОЖАРА И ПОРАЖЕНИЯ ЭЛЕКТРОТОКОМ,
НЕ ДОПУСКАЙТЕ ДЕЙСТВИЯ НА ТЕЛЕВИЗОР ДОЖДЯ ИЛИ ВЛАГИ.**

ВНИМАНИЕ:

**ПРИ ИСПОЛЬЗОВАНИИ ТЕЛЕВИЗОРА СОБЛЮДАЙТЕ
СЛЕДУЮЩИЕ ПРАВИЛА ЛИЧНОЙ БЕЗОПАСНОСТИ.**

- 1 Подключайте телевизор только к источникам питания, параметры которых соответствуют параметрам, указанным на задней стенке телевизора.
- 2 Не допускайте повреждений шнура и вилки питания. При отключении телевизора от сети выньте вилку из розетки, держась за вилку, а не за шнур.
- 3 Ни в коем случае не перегораживайте и не закрывайте вентиляционные отверстия. Ни в коем случае не устанавливайте телевизор в местах с плохой вентиляцией.

При установке телевизора оставьте вентиляционные зазоры по периметру, величина зазоров должна быть не меньше показанных на рис значений.

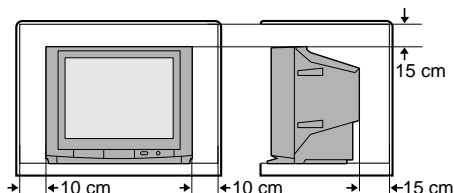

- 4 Не допускайте попадания предметов или жидкости в отверстия корпуса.
- 5 В случае неисправности выньте вилку питания из розетки и вызовите мастера. Не пытайтесь отремонтировать телевизор самостоятельно, не открывайте заднюю крышку.
- 6 Поверхность экрана телевизора может быть легко повреждена. При обращении с телевизором соблюдайте предельную осторожность. Если экран загрязнится, протрите его мягкой сухой тканью. Ни в коем случае не нажимайте сильно на экран. Ни в коем случае не используйте чистящие или моющие средства.
- 7 Если Вы не собираетесь пользоваться телевизором в течение длительного времени, обязательно отключите его от сетевой розетки.

В соответствии с Законом Российской Федерации “О защите прав потребителей” срок службы (годности) данного товара “по истечении которого он может представлять опасность для жизни, здоровья потребителя, причинять вред его имуществу или окружающей среде” составляет семь (7) лет со дня производства. Этот срок является временем в течение которого потребитель данного товара может безопасно им пользоваться при условии соблюдения руководства по эксплуатации данного товара, проводя необходимое обслуживание, включающее замену расходных материалов и/или соответствующее ремонтное обеспечение в специализированном сервисном центре JVC. Дополнительные косметические материалы к данному товару, поставляемые вместе с ним, могут храниться в течение двух (2) лет со дня его производства.

Срок службы (годности), кроме срока хранения дополнительных косметических материалов, упомянутых в предыдущих двух пунктах, не затрагивает никаких других прав потребителя, в частности гарантийного свидетельства JVC, которое он может получить в соответствии с законом о правах потребителя или других законов, связанных с ним.

Настройка телевизора

ВНИМАНИЕ

- Перед каким-либо подсоединением выключите всю аппаратуру, в том числе телевизор.

1 Подсоединение антенны и ВМ

- Антенный кабель в комплект поставки не входит. Используйте качественный 75-Ом коаксиальный кабель.
- Перед подсоединением прочтите руководство по ВМ.

Если ВМ не подсоединяется (см. рис. А):

Подсоедините антенный кабель к гнезду антенны телевизора.

Если ВМ подсоединяется (см. рис. В):

- 1 Подсоедините антенный кабель к входному гнезду антенны ВМ и соедините ВМ и телевизор друг с другом с помощью другого антенного кабеля.
- 2 Соедините видеокабелем гнездо VIDEO OUT (выход видео) видеомagniтофона и гнездо VIDEO (видео) телевизора.

Для соединения ВМ с телевизором с помощью кабеля S-VIDEO выполните следующее:

Соедините разъем S-VIDEO OUT видеомagniтофона и разъем S телевизора с помощью кабеля S-VIDEO (А), а не видеокабеля.

- 3 Соедините гнезда VIDEO OUT (L/R аудиовыходы) видеомagniтофона и гнезда AUDIO (L/MONO и R) телевизора с помощью аудиокабеля.

- Если аудиовыход видеомagniтофона является монофоническим, соедините гнездо AUDIO OUT (аудиовыход) видеомagniтофона и гнездо AUDIO L/MONO (аудио л/моно) телевизора с помощью аудиокабеля.

- Если ВМ имеет гнездо AV COMPU LINK, можно воспользоваться функцией AV COMPU LINK. Более подробную информацию можно найти в разделе "Подсоединение устройств, поддерживающих AV COMPU LINK" на стр. 38.

рис. А



рис. В



2 Подсоединение шнура питания

Вставьте вилку шнура в сетевую розетку.

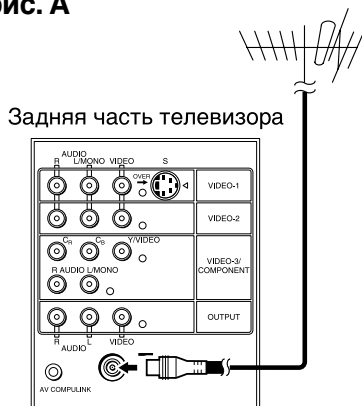
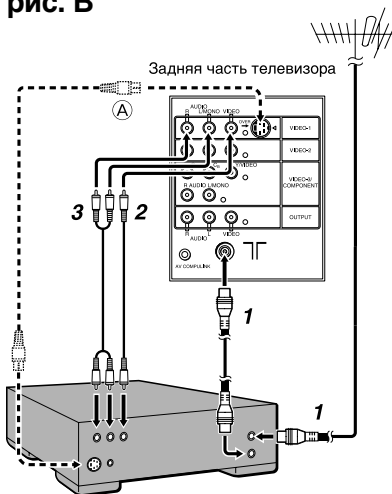
3 Установка батареек в пульт дистанционного управления

Возьмите 2 батарейки AA/R6.

Вставьте батареи, начиная с кнопки, помеченного знаком ⊖ и соблюдая полярности ⊕ и ⊖ .

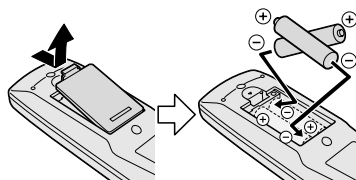

- Соблюдайте инструкции по безопасности, указанные на батарейках.
- Если пульт дистанционного управления нормально не работает, замените батарейки.
- Батарейки, входящие в комплект поставки, предназначены только для настройки и проверки телевизора. Замените эти батарейки как можно скорее.

4 Выполнение первоначальных настроек

При первом включении телевизор входит в режим первоначальных настроек, на экране появляется логотип JVC.

1 Нажмите кнопку включения питания телевизора

Телевизор включится и появится логотип JVC.

- Если индикатор питания телевизора остается красным и не становится зеленым, это означает, что телевизор находится в режиме ожидания. Для включения телевизора нажмите кнопку POWER на пульте дистанционного управления.
- Если логотип JVC не появляется, это означает, что телевизор уже включался. В этом случае для выполнения начальных настроек воспользуйтесь функциями "ЯЗЫК" и "АВТО ПРОГ". Более подробную информацию см. в разделе "Меню НАСТРОЙКИ" на стр. 29.

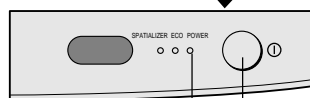
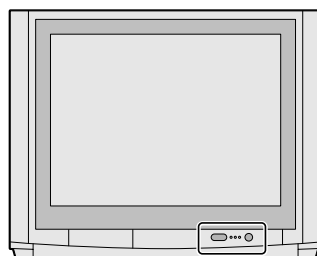

Индикатор питания
POWER

Кнопка
выключателя
сети

2 Нажмите кнопку MENU/OK

Появится меню ЯЗЫК. Выберите один из языков из появившегося на экране списка.

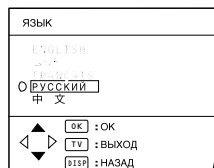

3 Нажимая кнопки ▲/▼, выберите РУССКИЙ. После этого нажмите кнопку MENU/OK.

Включится функция АВТО ПРОГ.
Принимаемые телевизионные телеканалы будут автоматически сохраняться в памяти телевизора в виде списка номеров программ.



- Для отмены функции АВТО ПРОГ. нажмите кнопку DISPLAY.

4 После сохранения телеканалов в списке номеров программ появится меню НАСТРОЙКА.

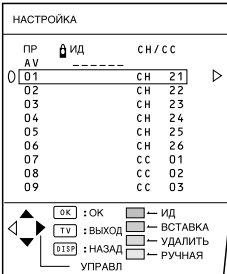

- После этого можно редактировать список номеров программ с помощью функции НАСТРОЙКА/ВРУЧНУЮ. Более подробную информацию см. в разделе "НАСТРОЙКА/ВРУЧНУЮ" на стр. 30.
- Если нужный телеканал не сохранен в списке номеров программ, его можно зарегистрировать с помощью функции РУЧНАЯ. Более подробную информацию см. в разделе "НАСТРОЙКА/ВРУЧНУЮ" на стр. 30.
- Функция АВТО ПРОГ. не сохраняет телеканалы на программе с номером 0 (AV).
- Если функция НАСТРОЙКА/ВРУЧНУЮ в данный момент не нужна, нажмите кнопку MENU/OK для закрывания меню НАСТРОЙКА.

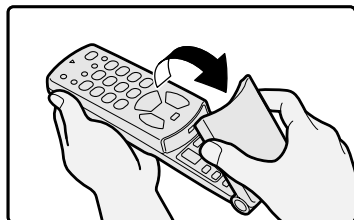
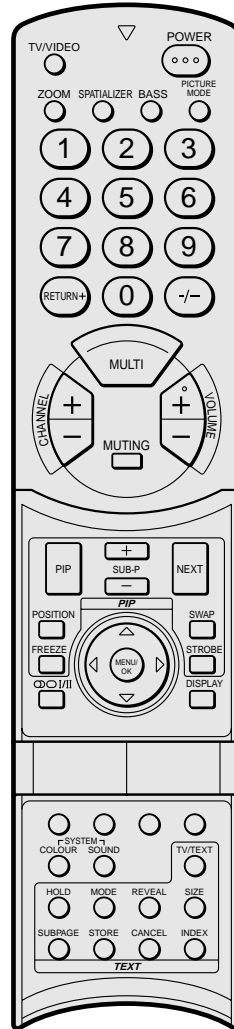

На этом настройка заканчивается.
Новый телевизор JVC к Вашим услугам!

Кнопки и функции телевизора

Включение питания

Нажмите кнопку питания ① .

Индикатор питания POWER ② загорится красным и телевизор войдет в режим ожидания.

Для выключения питания :

снова нажмите кнопку питания.

Индикатор питания POWER ② погаснет.

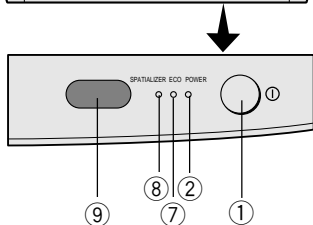
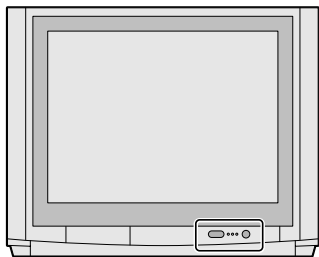

Включение телевизора, находящегося в режиме ожидания

Нажмите одну из кнопок CHANNEL +/- ⑤ .

Индикатор питания POWER ② изменит цвет с красного на зеленый и телевизор включится.

- Находящийся в режиме ожидания телевизор можно также включить нажимом кнопки TV/VIDEO ③ .

Выбор телеканала

Нажимайте кнопки CHANNEL +/- ⑤ .

Выбор панели ВИДЕО

Нажимайте кнопки TV/VIDEO ③ или CHANNEL +/- ⑤ .

Регулировка громкости

Нажимайте кнопки VOLUME +/- ④ .

Появится индикатор уровня громкости.

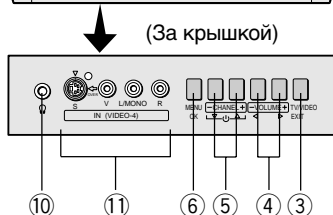
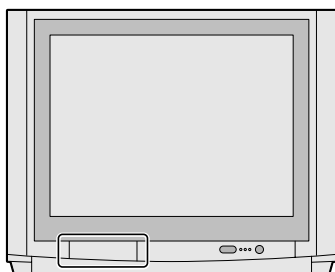

Кнопка MENU ⑥

Нажимом этой кнопки открывается меню.

Более подробную информацию см. в разделе "Использование кнопок телевизора" на стр. 19.

Датчик пульта дистанционного управления и ЭКО-сенсор ⑨

Индикатор ECO ⑦

Если установить функцию ЦИФРОВОЙ ЭКОСЕНСОР на ВКЛ или ДИСПЛЕЙ, загорится индикатор ECO.

Индикатор SPATIALIZER ⑧

Этот индикатор загорается, если установить функцию SPATIALIZER на МОНО или LIVE.

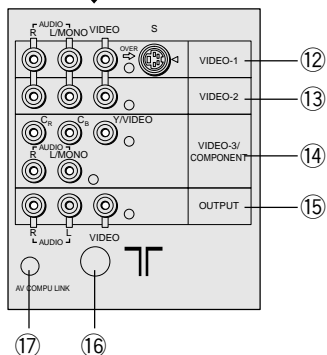
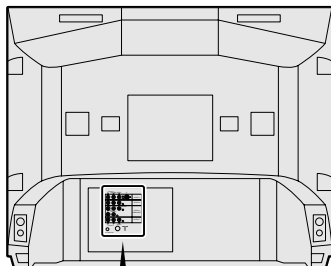

Гнездо головного телефона ⑩

Для подключения головных телефонов используйте стерео минигнездо (диаметр 3,5 мм).

При использовании головных телефонов следуйте инструкциям, приведенным в разделе "НАУШНИКИ" на стр. 25.

Панель VIDEO-1 ⑫

- См. стр. 3 и 36.

Панель VIDEO-2 ⑬

- См. стр. 36.

Панель VIDEO-3/COMPONENT ⑭

- См. стр. 28 и 36.

Панель VIDEO-4 ⑪

- См. стр. 36.

Панель OUTPUT ⑮

- См. стр. 36.

Гнездо антенны ⑯

Подсоедините антенный кабель.

- См. стр. 3.

Панель AV COMPU LINK ⑰

- См. стр. 36 и 38.

Кнопки и функции пульта дистанционного управления

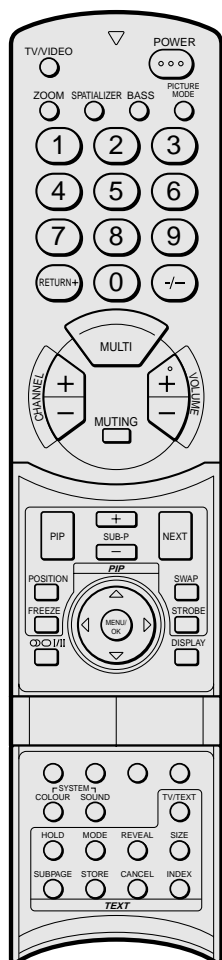

Включение телевизора, находящегося в режиме ожидания

Нажмите кнопку **POWER**.

Цвет индикатора питания **POWER** изменится с красного на зеленый и телевизор включится.

- Телевизор, находящийся в режиме ожидания, можно включить нажатием кнопки **TV/VIDEO**, кнопки **CHANNEL +/-** или кнопок с номерами.

Для выключения телевизора:

Снова нажмите кнопку **POWER**.

Цвет индикатора питания **POWER** изменится с зеленого на красный и телевизор войдет в режим ожидания.

Выбор телеканала

Выберите номер программы, под которым был запомнен телеканал.

Нажимайте кнопку **CHANNEL +/-** или введите номер программы (ПР) с помощью кнопок с номерами.

- Если нужно ввести двузначный номер, нажмите кнопку **-/-** для перехода на двузначную систему.
- телеканал можно выбрать из списка **ПРОГ. ЛИСТ**. Более подробную информацию см. в разделе "Кнопка **DISPLAY**" на стр. 11.
- Если изображение нечеткое или нет звука, выполните инструкции в разделе "Кнопка **COLOUR SYSTEM**" на стр. 11.
- Если звук хорошего качества не появляется даже при получении хорошего изображения на экране, выполните инструкции в разделе "Кнопка **SOUND SYSTEM**" на стр. 12.

Регулирование громкости

Нажимайте кнопки **VOLUME +/-**.

- Громкость головных телефонов этими кнопками не регулируется. Следуйте инструкциям в разделе "НАУШНИКИ" на стр. 25.

Просмотр изображения с внешнего устройства

Выберите панель **VIDEO**, через которую подсоединяется внешнее устройство.

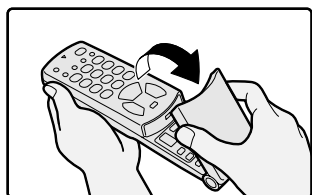

Нажмите кнопку TV/VIDEO.

- Панель VIDEO можно выбрать с помощью кнопку CHANNEL +/- или из списка ПРОГ. ЛИСТ.

Для возврата к телеканалу:

Нажмите кнопку TV/VIDEO, кнопку CHANNEL +/- или кнопку с номером.

Кнопка MUTING

Кнопка MUTING используется для выключения звука. Повторный нажим кнопки MUTING приводит к включению звука на той же громкости, которая была до выключения звука.

Кнопка ZOOM

Имеется возможность изменения формата изображения на экране путем изменения формата. Выберите оптимальный формат с помощью следующих режимов ZOOM.

Для выбора режима нажмите кнопку ZOOM.

- Если при приеме Progressive видеосигнала (сигналов 525P) нажать кнопку ZOOM, на экране появится надпись сигнал "525P" и функция ZOOM работать не будет.

НОРМАЛЬНОЕ

Используется для получения нормального, неизмененного изображения (формат 4:3).

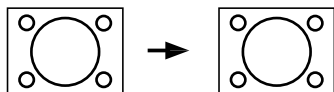

ZOOM

Можно укрупнить широкоформатное изображение (формат 16:9), так что оно заполнит весь экран.



- Левый и правый края широкоформатного изображения (формат 16:9) будут отрезаны.

16:9

Этот режим обеспечивает преобразование нормального изображения (формат 4:3) в широкоформатное изображение (формат 16:9).



- Этот режим используется для изображений с форматом 16:9, сжатых до обычного формата (формат 4:3), он позволяет восстановить первоначальный формат.

Кнопка SPATIALIZER

С помощью функции SPATIALIZER можно получать "живой" (Live) эффект при использовании системы Surround sound (окружающий звук).

Нажмите кнопку SPATIALIZER для выбора режима.

LIVE:

Этот режим дает возможность преобразования обычного стереозвuka в окружающий звук с увеличенной глубиной и окружающими эффектами.

МОНО:

Этот режим дает возможность преобразования обычного монозвuka в звук, имитирующий стереофоническое звучание.

ВЫКЛ:

Этот режим выключения.

- Режим LIVE нормально работает только в случае стереозвuka.
- Режим LIVE не работает при прослушивании через головные телефоны.
- Режим МОНО нормально работает только в случае монозвuka.

Система SPATIALIZER изготовлена по лицензии компании Desper Products, Inc.

Кнопки и функции пульта дистанционного управления

Кнопка BASS

Для включения мощных басов можно использовать функцию СУПЕР БАС.

Для включения и выключения функции СУПЕР БАС нажимайте кнопку BASS.

ВКЛ :

Функция включается.

ВЫКЛ :

Функция выключается.

Кнопка PICTURE MODE

Можно выбрать один из трех режимов ПРЕДУСТАНОВКИ для автоматического регулирования параметров изображения.

Для выбора режима нажимайте кнопку PICTURE MODE.

ЯРКИЙ :

Повышает контрастность и четкость.

СТАНДАРТ :

Делает параметры изображения стандартными.

МЯГКИЙ :

Смягчает контрастность и четкость.

Кнопка RETURN+

Кнопка RETURN+ выполняет две функции: ВОЗВРАТ+ и ВОЗВРАТ.

Если телеканал зарегистрирован как "Возвращаемый телеканал", для этого телеканала действует функция ВОЗВРАТ+. Если телеканал не зарегистрирован как "Возвращаемый телеканал", для этого телеканала действует функция ВОЗВРАТ.

Функция ВОЗВРАТ+ :

Зарегистрировав часто используемый телеканал как "Возвращаемый телеканал", можно выбирать этот телеканал в любой момент путем нажима кнопки RETURN+.

Для регистрации телеканала как "Возвращаемый телеканал" :

Выберите номер программы, назначенный для этого телеканала, нажмите кнопку RETURN+ и держите ее нажатой в течение не менее 3 секунд. Появление на экране надписи "ВОЗВРАТ КАНАЛА ЗАПРОГРАММИРОВАН!" подтверждает завершение регистрации.

Для отмены регистрации телеканала как "возвращаемого" :

при просмотре любого телеканала нажмите кнопку RETURN+ и держите ее нажатой в течение не менее 3 секунд. На экране появится надпись "ВОЗВРАТ КАНАЛА ОТМЕНЕН!", что означает отмену регистрации.

- При выключении телевизора регистрация "возвращаемого телеканала" отменяется.
- Если Вы хотите попеременно смотреть "Возвращаемый телеканал" и какой-либо другой телеканал, сначала выберите этот другой телеканал, после этого нажимом кнопки RETURN+ можно будет переключиться на "возвращаемый" телеканал. Таким образом с помощью кнопки RETURN+ можно переключаться между двумя телеканалами.

Функция ВОЗВРАТ :

Телевизор временно запоминает телеканал, который был выбран последним перед просматриваемым в данный момент телеканалом, как "Последний телеканал". С помощью кнопки RETURN+ можно переключаться между просматриваемым в данный момент телеканалом и "Последний телеканал".

- Если Вы хотите смотреть два телеканала попеременно с использованием функции ВОЗВРАТ, выберите сначала один, а затем второй телеканал с помощью кнопок с цифрами. Если выбрать телеканал, не используя кнопки с цифрами, в качестве "Последний телеканал" может зарегистрироваться не тот телеканал, который был выбран первым.

Кнопка ∞ ○ I/II

При просмотре двуязычных программ можно выбирать звуковое сопровождение Язык 1 (Bilingual I (Sub I)) или Язык 2 (Bilingual II (Sub II)). При плохом приеме стереотрансляции можно переключиться со стерео на моно для улучшения четкости звука.

Нажмите кнопку ∞ ○ I/II для выбора режима звучания.

∞ : Стерефония

○ : Монофония

I : Язык I (sub I)

II : Язык II (sub II)

МОНО : Отменяет функцию Multi Sound, звук становится монофоническим.

- Возможные режимы звучания зависят от телевизионной программы.
- Эта функция не работает в режимах ВИДЕО.

Кнопка DISPLAY

Дает возможность отображения на экране ПРОГ. ЛИСТ, номера программы или номера панели ВИДЕО.

Нажмите кнопку DISPLAY.

Нажим кнопки DISPLAY приводит к следующему изменению информации на экране.

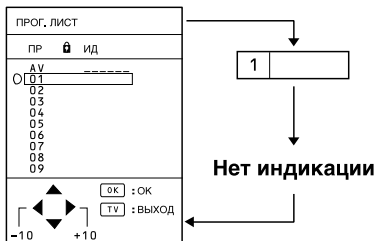

Выбор телеканала или панели ВИДЕО.

1 Нажмите кнопку DISPLAY для отображения ПРОГ. ЛИСТ.

2 Кнопками ▲/▼ и ◀/▶ выберите номер программы или панели ВИДЕО. Затем нажмите кнопку MENU/OK.

- Рядом с номером программ в ПРОГ ЛИСТ, для которых задана функция ИД НОМЕР, появляется знак этой функции .
- Номера панелей ВИДЕО регистрируются после программы с номером ПР 99.

Кнопка COLOUR SYSTEM

Система цветности выбирается автоматически, однако, если изображение нечеткое или нецветное, выберите систему цветности вручную.

Для выбора системы цветности используйте кнопку COLOUR SYSTEM.

АВТО :

Этот режим обеспечивает распознавание системы цветности по входному сигналу.

- При плохом качестве сигнала работа функции АВТО может нарушиться. При плохом качестве изображения в режиме АВТО выберите другую систему цветности вручную.
- Функция АВТО распознает систему цветности по выходному сигналу и выбирает соответствующую систему цветности автоматически.
- В случае выбора СИСТЕМЫ ЦВЕТНОСТИ дополнительного изображения (SUB-picture), см. раздел "Изменение системы цветности ВТОРОСТЕПЕННОГО изображения" на стр. 15.
- Системы цветности, используемые в различных странах и регионах, указаны в таблице "ТЕЛЕВЕЩАТЕЛЬНЫЕ СИСТЕМЫ" на стр. 12.

Кнопка SOUND SYSTEM

Система звукового сопровождения (Sound System) выбирается автоматически. Однако, если звуковое сопровождение слышно с помехами при нормальном изображении, выберите систему звукового сопровождения вручную.

Для выбора нужной системы звукового сопровождения нажимайте кнопку SOUND SYSTEM.

V/G : система V/G

I : система I

D/K : система D/K

M : система M

- Эта функция не работает в режиме ВИДЕО.
- Системы звукового сопровождения, используемые в различных странах и регионах, приведены в таблице "ТЕЛЕВЕЩАТЕЛЬНЫЕ СИСТЕМЫ" на стр. 12.

ТЕЛЕВЕЩАТЕЛЬНЫЕ СИСТЕМЫ

По следующим таблицам можно найти системы звукового сопровождения и системы цветности, используемые в вашем регионе.

СИСТЕМЫ ЦВЕТНОСТИ

Часть света	Страна или регион	Система
Азия, Ближний Восток	Бахрейн, Кувейт, Оман, Катар, Объединенные Арабские Эмираты, Йемен и т.д., Индонезия, Малайзия, Сингапур, Таиланд, Индия и т.д..	PAL
	Китай, Вьетнам и т.д.	PAL
	Гонконг и т.д.	PAL
	Исламская Республика Иран, Ливан, Саудовская Аравия и т.д.	SECAM
Европа	Филиппины, Тайвань, Мьянма и т.д.	NTSC
	Россия и т.д.	SECAM
	Чешская Республика, Польша и т.д.	PAL
	Германия, Голландия, Бельгия и т.д.	PAL
Океания	Великобритания и т.д.	PAL
	Австралия, Новая Зеландия и т.д.	PAL
Африка	Южно-Африканская Республика и т.д.	PAL
	Нигерия и т.д.	PAL
	Египет, Марокко и т.д.	SECAM

СИСТЕМЫ ЗВУКОВОГО СОПРОВОЖДЕНИЯ

Часть света	Страна или регион	Система
Азия, Ближний Восток	Бахрейн, Кувейт, Оман, Катар, Объединенные Арабские Эмираты, Йемен и т.д., Индонезия, Малайзия, Сингапур, Таиланд, Индия и т.д..	V/G
	Китай, Вьетнам и т.д.	D/K
	Гонконг и т.д.	I
	Исламская Республика Иран, Ливан, Саудовская Аравия и т.д.	V/G
Европа	Филиппины, Тайвань, Мьянма и т.д.	M
	Россия и т.д.	D/K
	Чешская Республика, Польша и т.д.	D/K
	Германия, Голландия, Бельгия и т.д.	V/G
Океания	Великобритания и т.д.	I
	Австралия, Новая Зеландия и т.д.	V/G
Африка	Южно-Африканская Республика и т.д.	I
	Нигерия и т.д.	V/G
	Египет, Марокко и т.д.	V/G

Кнопка FREEZE

Имеется возможность представления стоп-кадра ГЛАВНОГО изображения в виде ВТОРОСТЕПЕННОГО изображения.

Нажмите кнопку FREEZE.

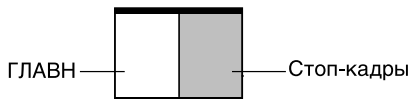

Для отмены функции ЗАМОРОЗИТЬ :

Снова нажмите кнопку FREEZE.

- Когда на экране имеется ВТОРОСТЕПЕННОЕ изображение и ГЛАВНОЕ изображение, кнопкой FREEZE пользоваться нельзя.
- Если при приеме Progressive видеосигнала (сигналов 525P) нажать кнопку FREEZE, на экране появится надпись сигнал "525P" и функция FREEZE работать не будет.

Кнопка STROBE

Эта кнопка дает возможность отображения ГЛАВНОГО изображения в виде 15 последовательных стоп-кадров.

Нажмите кнопку STROBE.

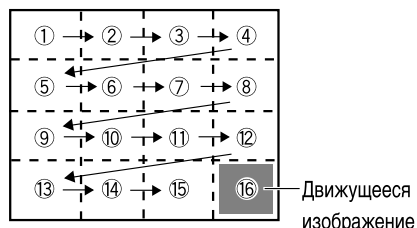

Для отмены функции STROBE :

нажмите кнопку STROBE для возврата к ГЛАВНОМУ изображению.

- При слабом сигнале ГЛАВНОГО изображения стоп-кадры воспроизводятся с искажениями.

- Когда на экране имеется ВТОРОСТЕПЕННОЕ изображение и ГЛАВНОЕ изображение, кнопкой STROBE пользоваться нельзя.
- Если при приеме Progressive видеосигнала (сигналов 525P) нажать кнопку STROBE, на экране появится надпись сигнал "525P" и функция STROBE работать не будет.
- Установки тональности ЦВ. ТОН не могут быть изменены для неподвижных изображений на экране, даже при просмотре программ в системе цветности NTSC.

■ Использование функции MULTI

Эта функция дает возможность вызова на экран нескольких изображений с тем, чтобы облегчить выбор наиболее интересной программы.

1 Нажмите кнопку MULTI.

В результате нажатия кнопки MULTI экран изменяется следующим образом.

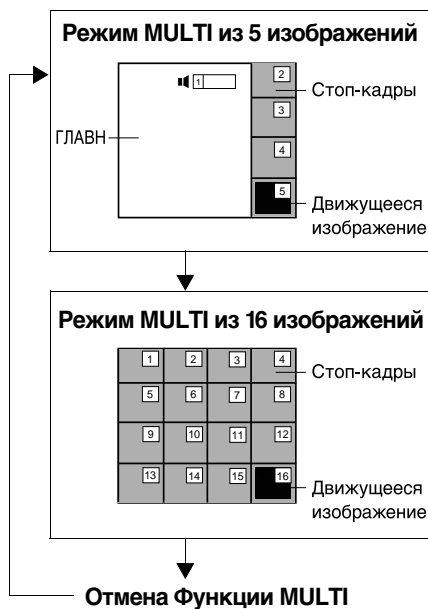

Для вызова на экран следующего изображения Multi :

нажмите кнопку NEXT.

2 Выберите изображение с помощью кнопок ▲/▼ и ◀/▶, а затем нажмите кнопку MENU/OK.

Экран переключится на выбранный телеканал или режим ВИДЕО.

- Номера программ, на которых никакие телеканалы не зарегистрированы, и номера программ, для которых назначена функция ИД, НОМЕР, не отображаются.
- Выполнять операции с меню, такие как регулировка громкости головных телефонов, нельзя. Для выполнения операций с меню отмените функцию MULTI.
- Если при приеме Progressive видеосигнала (сигналов 525P) нажать кнопку MULTI, на экране появится надпись сигнал "525P" и функция MULTI работать не будет.
- В течение непродолжительного периода, необходимого для закрывания дисплея многочисленных изображений, звуковое сопровождение будет отсутствовать.

■ Использование функции PIP

Имеется возможность одновременного просмотра двух изображений (ГЛАВН и ВТОРОСТЕП).

Нажмите кнопку PIP.

Нажим кнопки PIP изменяет изображение на экране следующим образом:

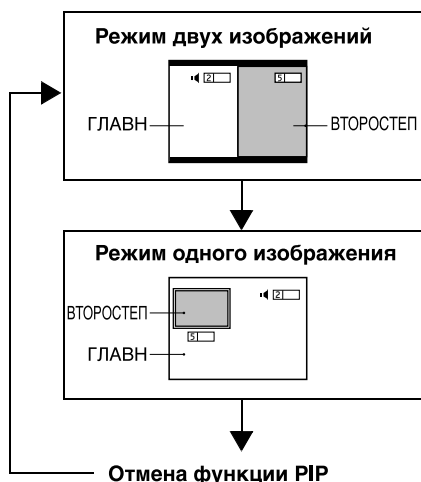

- Смотреть изображение одной и той же программы (или через одну и ту же панель ВИДЕО) одновременно как ГЛАВНОЕ и ВТОРОСТЕПЕННОЕ нельзя.
- При плохом сигнале ГЛАВНОГО изображения сигнал ВТОРОСТЕПЕННОГО изображения может также быть плохим.
- Если стандарты основного и дополнительного изображений различны, их верхние и нижние части могут исчезнуть.
- При просмотре изображений с использованием функции PIP функция ZOOM не работает.
- ДОПОЛНИТЕЛЬНОЕ изображение нельзя получить в виде выходного сигнала телевизора.
- Если при приеме Progressive видеосигнала (сигналов 525P) нажать кнопку PIP, на экране появится надпись сигнал "525P" и функция PIP работать не будет.

Выбор телеканала для ВТОРОСТЕПЕННОГО изображения

Нажмите кнопку SUB-P +/-.

Прослушивание звукового сопровождения ВТОРОСТЕПЕННОГО изображения

Звуковое сопровождение ДОПОЛНИТЕЛЬНОГО изображения можно прослушивать через головные телефоны, при этом звуковое сопровождение ОСНОВНОГО изображения будет передаваться через громкоговорители телевизора. Более подробную информацию см. в разделе "НАУШНИКИ" на стр. 25.

Изменение системы цветности ВТОРОСТЕПЕННОГО изображения

- 1 Когда на экране имеется ВТОРОСТЕПЕННОЕ изображение, нажмите кнопку MENU/OK для вызова на экран МЕНЮ (основное меню).
- 2 Нажмите кнопки ▲/▼ и ◀/▶ для выбора СВОЙСТВА ИЗОБРАЖЕНИЯ, а затем кнопку MENU/OK.
- 3 Нажмите кнопку ▲/▼ для выбора СИСТЕМА ЦВЕТНОСТИ, а затем кнопку MENU/OK.

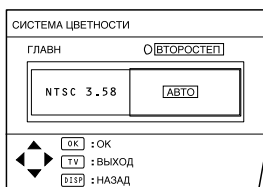

- 4 Нажмите кнопку ◀/▶ для выбора ВТОРОСТЕП, а затем кнопку ▲/▼ для выбора нужной системы цветности. После этого нажмите кнопку MENU/OK.

- Изменять СИСТЕМУ ЦВЕТНОСТИ ВТОРОСТЕПЕННОГО изображения с помощью кнопки COLOUR SYSTEM пульта дистанционного управления нельзя.

Кнопка POSITION

Имеется возможность регулирования ВТОРОСТЕПЕННОГО изображения при использовании режима "Режим одного изображения".

Нажимайте кнопку POSITION.

При каждом нажмие этой кнопки ВТОРОСТЕПЕННОЕ изображение будет перемещаться в направлении против часовой стрелки.

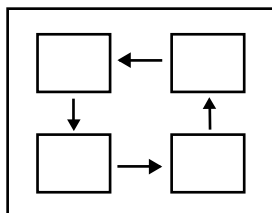

Кнопка SWAP

Эта кнопка дает возможность менять местами ГЛАВНОЕ и ВТОРОСТЕПЕННОЕ изображения.

Нажмите кнопку SWAP.

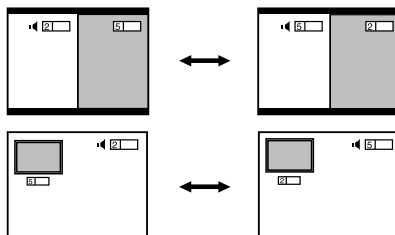

- Не нажимайте кнопку SWAP при записывании телепрограммы на VM - это приведет к изменению выходного сигнала телевизора.

■ Просмотр программы с телетекстом

- 1 Выберите телеканал с телетекстом.
- 2 Нажмите кнопку TV/TEXT.

Нажим кнопки TV/TEXT изменяет режим следующим образом:

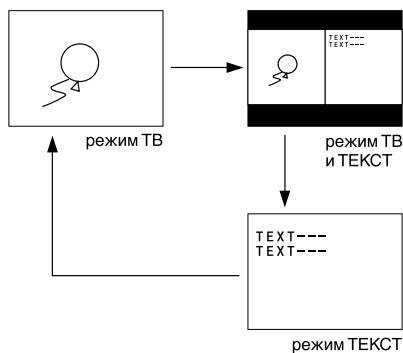

- 3 Выберите страницу телетекста с помощью кнопок CHANNEL +/-, кнопку с цифрами или цветных кнопок.

Для возврата к режиму ТВ :
нажмите кнопку TV/TEXT или кнопку TV/VIDEO.

- Если возникают проблемы при приеме программ с телетекстом, обратитесь к местному дилеру или телевизионной компании.
- В режиме Текст ZOOM зафиксирован на режиме НОРМАЛЬНОЕ.
- При просмотре программ с телетекстом операции с меню выполнять нельзя.
- При неверном выводе на экран символов телетекста измените установку ЯЗЫК ТЕЛЕТЕКСТА. Подробные сведения см. под заголовком "ЯЗЫК ТЕЛЕТЕКСТА" на стр. 34.

Кнопка HOLD

Имеется возможность сохранения (HOLD) страницы телетекста на экране сколь угодно долго, даже когда принимается несколько других страниц телетекста.

Нажмите кнопку HOLD

В левом верхнем углу экрана появится

Для отмены функции Hold :
снова нажмите кнопку HOLD.

Кнопка REVEAL

На некоторых страницах телетекста имеется скрытый текст (например, ответы на вопросы викторины).
Имеется возможность вызова на экран скрытого текста.

При каждом нажиме на кнопку REVEAL текст исчезает или появляется.

Кнопка SIZE

Имеется возможность увеличения высоты дисплея телетекста вдвое.

Нажмите кнопку SIZE.

Кнопка INDEX

Имеется возможность мгновенного возврата к странице содержания.

Нажмите кнопку INDEX.

- В режиме Список можно вернуться к странице, номер которой отображается в левом нижнем углу экрана.

Кнопка CANCEL

Имеется возможность поиска страницы телетекста при просмотре телепрограмм.

- 1 Нажимая кнопки с цифрами, введите номер страницы или нажмите цветную кнопку.

Телевизор начинает искать страницу телетекста.

2 Нажмите кнопку CANCEL.

Появится телепрограмма. Когда телевизор найдет страницу телетекста, ее номер появится в левом верхнем углу экрана.

3 Нажмите кнопку CANCEL для возврата к странице телетекста, когда ее номер появится на экране.

- С помощью кнопки CANCEL вернуться в режим ТВ нельзя.

Кнопка SUBPAGE

Некоторые страницы телетекста имеют автоматически отображаемые подстраницы. Имеется возможность сохранения подстраницы на экране или ее просмотра в любой момент времени.

1 Нажмите кнопку SUBPAGE для включения функции Подстраница.

Номера подстраниц отображаются в нижней части экрана.

Цвет*	Состояние подстраницы
Желтый	На экране в настоящий момент.
Белый	Может быть вызвана на экран.
Синий или красный	Не может быть вызвана на экран и не послана.

* : Цвет фона, на котором отображается номер подстраницы.

2 Нажимайте кнопки CHANNEL +/- для выбора номера подстраницы.

Для отмены функции Подстраница : снова нажмите кнопку SUBPAGE.

Использование режима Список

Вы можете сохранять номера любимых страниц телетекста в памяти и быстро вызывать их из памяти с помощью цветных кнопок.

Для сохранения номеров страниц :

1 Нажмите кнопку MODE для входа в режим Список.

В нижней части экрана отобразятся имеющиеся в памяти номера страниц.

2 С помощью цветной кнопки выберите номер (позицию). Затем с помощью кнопок с цифрами введите номер страницы.

3 Нажмите и удержите кнопку STORE.

Четыре номера страниц будут мигать на экране, что указывает на сохранение их в памяти.

Для вызова сохраненной страницы :

1 Нажмите кнопку MODE для входа в режим Список.

2 Нажмите цветную кнопку, для которой был назначен нужный номер страницы.

Для выхода из режима Список :

снова нажмите кнопку MODE

Как пользоваться меню телевизора

Рядом функций телевизора можно управлять с помощью меню.

Чтобы иметь возможность использования всех функций телевизора, необходимо хорошо знать принципы работы меню.

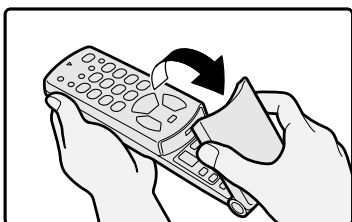
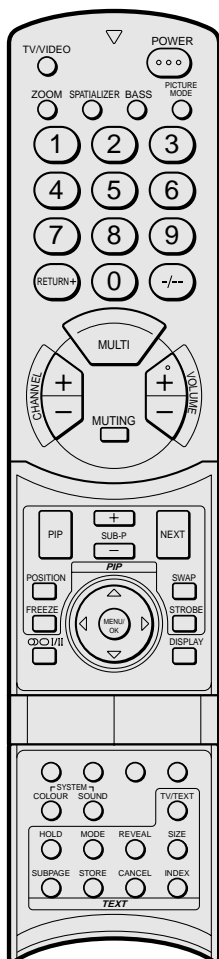

Основные операции

- 1 Нажмите кнопку MENU/OK для вызова МЕНЮ (основного меню).

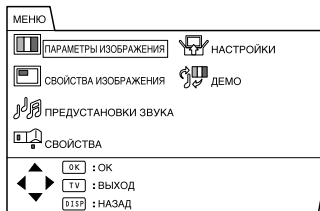

- На дисплее снизу от меню показаны кнопки пульта дистанционного управления, которыми можно пользоваться для управления выбранной функцией.

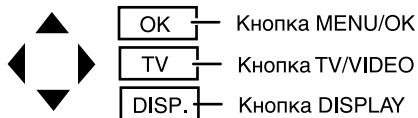

- 2 Нажимая кнопки ▲/▼ и ◀/▶ выберите название меню, а затем нажмите кнопку MENU/OK.

Появится меню.

Для возврата к предыдущему меню :
нажмите кнопку DISPLAY.

Для мгновенного выхода из меню :
нажмите кнопку TV/VIDEO.

- 3 С помощью кнопок ▲/▼ выберите функцию.

- Более подробную информацию о функциях в меню можно найти на последующих страницах.

4 Для выбора настройки этой функции используйте кнопки ◀/▶.

- Для использования функции, представленной только названием, прочтите описание этой функции на последующих страницах.

5 Нажмите кнопку MENU/OK для завершения настройки.

Меню исчезнет.

- При просмотре передач в системе NTSC меню имеют размер по вертикали вдвое меньший нормального размера меню.

Использование кнопок телевизора

Для управления меню можно использовать кнопки, предусмотренные на передней панели телевизора.

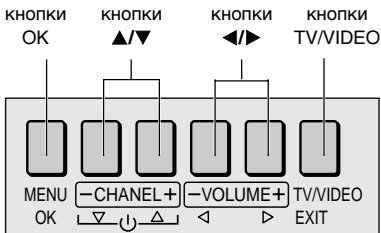

- На передней панели телевизора нет кнопки, имеющей функцию кнопки DISPLAY или цветной кнопки.

Меню ПАРАМЕТРЫ ИЗОБРАЖЕНИЯ

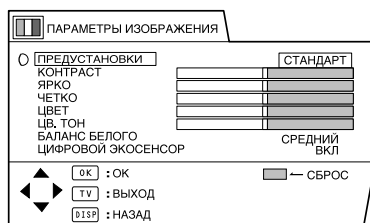

■ ПРЕДУСТАНОВКИ

Для автоматического регулирования параметров изображения можно выбрать одну из трех ПРЕДУСТАНОВКИ.

ЯРКИЙ :

Увеличивает контрастность и яркость.

СТАНДАРТ :

Делает параметры изображения "стандартными".

МЯГКИЙ :

Смягчает контрастность и четкость.

- Управление функцией ПРЕДУСТАНОВКИ можно также осуществлять с помощью кнопки PICTURE MODE на пульте дистанционного управления. Более подробную информацию см. в разделе "Кнопка PICTURE MODE" на стр. 10.

■ Регулирование изображения

Параметры каждой предустановки можно произвольно изменять. Внесенные изменения сохраняются и станут параметрами данной предустановки.

КОНТРАСТ

Контрастность изображения можно регулировать.

- ◀ : меньше
- ▶ : больше

ЯРКО

Яркость изображения можно регулировать.

- ◀ : темнее
- ▶ : светлее

ЧЕТКО

Четкость изображения можно регулировать.

- ◀ : меньше
- ▶ : больше

- Функция ЧЕТКО не работает при приеме Progressive видеосигналов (сигналов 525P).

ЦВЕТ

Цвет изображения можно регулировать.

- ◀ : бледнее
- ▶ : сочнее

ЦВ. ТОН

Цветовой тон изображения можно регулировать.

- ◀ : красноватый
- ▶ : зеленоватый

- Изменение параметра ЦВ. ТОН возможно только при использовании системы цветности NTSC 3.58 или NTSC 4.43.
- Функция ЦВ. ТОН не работает при приеме Progressive видеосигналов (сигналов 525P).

Для возврата к исходным параметрам ПРЕДУСТАНОВКИ:

Нажмите синюю кнопку. В результате настройки в выбранной в данный момент ПРЕДУСТАНОВКИ вернутся к исходным значениям, которые будут сохранены как настройки данной ПРЕДУСТАНОВКИ.

■ БАЛАНС БЕЛОГО

Для регулировки баланса белого можно выбирать один из трех режимов БАЛАНС БЕЛОГО (один из трех тонов белого). Поскольку белый цвет используется как базовый для всех остальных цветов, изменение режима БАЛАНС БЕЛОГО приводит к изменению представления на экране всех остальных цветов.

ХОЛОД :

Белый с голубизной. Использование этого режима при просмотре ярких изображений дает возможность получения более живых и ярких изображений.

СРЕДНИЙ :

Нормальный белый цвет.

ТЕПЛЫЙ :

Белый с красноватым оттенком. Использование этого режима при просмотре фильмов дает возможность получения более подходящих для фильмов цветов.

- Функция БАЛАНС БЕЛОГО не может быть выбрана в режиме "двойное изображение" или в режиме 16:9 функции ZOOM (изменения масштаба изображения).

■ ЦИФРОВОЙ ЭКОСЕНСОР

При выборе ЦИФРОВОЙ ЭКОСЕНСОР контрастность автоматически регулируется в соответствии с яркостью освещения в комнате. Это снижает напряжение глаз и потребляемую телевизором электроэнергию.

ВКЛ :

Данная функция включается.

ВЫКЛ :

Данная функция выключается.

ДИСПЛЕЙ :

Эта функция включается. При каждом изменении яркости в комнате на несколько секунд появляются значки ♣, обозначающие яркость. Чем темнее в комнате, тем больше число значков.

Меню СВОЙСТВА ИЗОБРАЖЕНИЯ

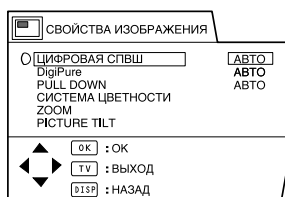

■ ЦИФРОВАЯ СПВШ

Функция ЦИФРОВАЯ СПВШ снижает помехи, искажающие изображение.

- Функция ЦИФРОВАЯ СПВШ не работает при приеме Progressive видеосигналов (сигналов 525P).

АВТО :

Телевизор автоматически регулирует уровень ЦИФРОВАЯ СПВШ в соответствии со степенью помех и обеспечит наилучшее изображение.

- Если установить слишком высокий уровень ЦИФРОВАЯ СПВШ, изображение может стать нечетким. Рекомендуется использовать режим АВТО.

МАКС :

Уровень ЦИФРОВАЯ СПВШ устанавливается на максимум. Если и после включения режима АВТО имеются помехи, переключитесь с АВТО на МАКС.

- Настройка МАКС не подходит для высококачественных изображений с сильными помехами.

МИН :

Уровень ЦИФРОВАЯ СПВШ устанавливается на минимум. Если после включения режима АВТО изображение стало недостаточно четким, переключитесь с АВТО на МИН.

- Настройка МИН не подходит для низкокачественных изображений с сильными помехами.

■ DigiPure

Функция DigiPure использует новейшую цифровую технологию для получения естественного изображения. Функция DigiPure включает две следующие функции.

Функция DigiPure :

Эта функция способствует созданию естественного изображения путем удаления лишних краевых зон высококонтрастных и четких изображений. В случае низкоконтрастных изображений краевые зоны добавляются для получения более четкого изображения. Функцию DigiPure можно установить в режим АВТО, МАКС и МИН.

Функция компенс ации движения изображения :

Эта функция обеспечивает более плавную и естественную передачу на экране быстро движущихся изображений, таких как изображение футболистов и мяча.

- Функция DigiPure не работает при приеме Progressive видеосигналов (сигналов 525P).

АВТО :

Телевизор автоматически отрегулирует уровень DigiPure в соответствии с уровнем искажений изображения и обеспечит наилучшее изображение.

- При слишком высоком уровне DigiPure и низкоконтрастном изображении с сильными помехами искажения могут еще больше усилиться. Рекомендуется использовать режим АВТО.

МАКС :

Уровень DigiPure устанавливается на максимум. Если после установки DigiPure на АВТО изображение передается не совсем полно, переключитесь с АВТО на МАКС.

- Режим МАКС не пригоден в случае низкоконтрастного изображения с сильными помехами.

МИН :

Уровень DigiPure устанавливается на минимум. Если после установки DigiPure на АВТО имеются помехи перейдите на МИН.

- Режим МИН не пригоден для высококачественных изображений со слабыми помехами.

ВЫКЛ :

Функция DigiPure выключается.

■ PULL DOWN

Включением функции PULL DOWN достигается более четкое и естественное изображение при просмотре широкоформатных кинофильмов.

АВТО:

Функция включена. В обычном режиме работы эта функция должна быть установленной на АВТО.

ВЫКЛ:

Функция выключена.

- Движение объектов может казаться неестественным при просмотре изображения в системе цветности NTSC. Чтобы обеспечить более плавное движение, переключите функцию PULL DOWN с АВТО на ВЫКЛ.
- Эта функция не может быть выбрана в режиме "двойного изображения" и в режиме "изображение в изображении".

■ СИСТЕМА ЦВЕТНОСТИ

Система цветности выбирается автоматически. Однако если изображение неясное или нецветное, выберите систему цветности вручную.

- 1 Выберите СИСТЕМА ЦВЕТНОСТИ и нажмите кнопку MENU/OK.

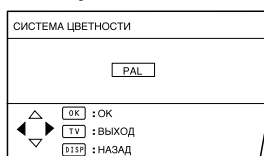

- 2 С помощью кнопок ◀/▶ выберите нужную систему цветности. Затем нажмите кнопку MENU/OK.

- В случае изменения СИСТЕМА ЦВЕТНОСТИ ВТОРОСТЕПЕННОГО изображения см. раздел "Изменение системы цветности ВТОРОСТЕПЕННОГО изображения" на стр. 15.
- Функцией СИСТЕМА ЦВЕТНОСТИ можно также управлять с помощью кнопки COLOUR SYSTEM пульта дистанционного управления. Более подробную информацию см. в разделе "Кнопка COLOUR SYSTEM" на стр. 11.

■ ZOOM

Имеется возможность изменения формата изображения на экране путем изменения коэффициента пропорциональности. Выберите оптимальный формат с помощью одного из трех режимов ZOOM.

- 1 Выберите ZOOM и нажмите кнопку MENU/OK.

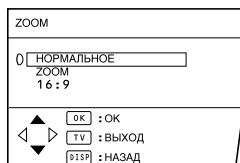

- 2 Нажимайте кнопки ▲/▼ для выбора режима ZOOM. Затем нажмите кнопку MENU/OK.

Изображение расширится, а название выбранного режима ZOOM остается на экране в течение около 5 секунд.

- Имеются следующие режимы : НОРМАЛЬНОЕ, ZOOM и 16:9. Более подробную информацию см. в разделе "Кнопка ZOOM" на стр. 9.
- Функция ZOOM не работает при приеме Progressive видеосигналов (сигналов 525P).

■ PICTURE TILT

Из-за влияния магнитного поля земли изображение может перекосяться. В этом случае можно откорректировать изображение с помощью этой функции.

- 1 Выберите PICTURE TILT и нажмите кнопку MENU/OK.

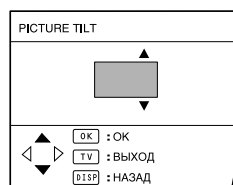

- 2 Нажимайте кнопки ▲/▼ до тех пор, пока перекося не устранился. Затем нажмите кнопку MENU/OK.

Меню ПРЕДУСТАНОВКИ ЗВУКА

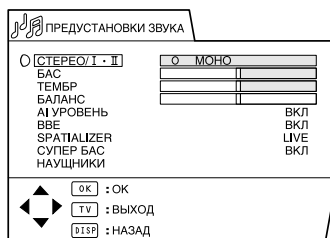

■ СТЕРЕО / I-II

При просмотре двуязычных программ можно выбирать звуковое сопровождение Язык I (Sub I) или Язык II (Sub II). При плохом приеме стереотрансляции можно переключиться со стерео на моно для улучшения четкости звука.

∞ : Стереофония

○ : Монофония

I : Язык I (sub I)

II : Язык II (sub II)

МОНО : Отменяет функцию Multi Sound, звук становится монофоническим.

- Возможные режимы звучания зависят от телевизионной программы.
- Эта функция не работает в режимах ВИДЕО.

■ Регулировка звука

Имеется возможность произвольного регулирования звука.

БАС

Можно регулировать нижние частоты звука.

◀ : слабее

▶ : сильнее

ТЕМБР

Можно регулировать верхние частоты звука.

◀ : слабее

▶ : сильнее

БАЛАНС

Можно регулировать баланс между левым и правым громкоговорителями.

◀ : увеличение громкости левого громкоговорителя.

▶ : увеличение громкости правого громкоговорителя.

■ AI УРОВЕНЬ

Эта функция дает возможность предотвращения резкого увеличения или уменьшения уровня громкости при переключении телеканалов и переключении с одного режима ВИДЕО на другой.

ВКЛ :

Функция включена.

ВЫКЛ :

Функция выключена.

- Функция AI УРОВЕНЬ может задаваться отдельно для режима ТВ и режима ВИДЕО.

Например, можно задать ее ВЫКЛ в режиме ТВ и ВКЛ в режиме ВИДЕО. Если установить функцию AI УРОВЕНЬ при просмотре изображений через панель ВИДЕО, эта установка зарегистрируется как настройка режима ВИДЕО.

- Функция AI УРОВЕНЬ может не давать нужных результатов при очень низком уровне громкости звукового сопровождения, передаваемого телевизионной станцией (или задаваемого программным обеспечением видеосистемы).

■ BBE

Функцию BBE можно использовать для простого придания звуковому сопровождению характеристик исходного, нескорректированного звукового сопровождения.

ВКЛ :

Функция включается.

ВЫКЛ :

Функция выключается.

Система BBE используется по лицензии компании BBE Sound, Inc. BBE является зарегистрированной торговой маркой компании BBE Sound, inc.

■ SPATIALIZER

С помощью функции SPATIALIZER можно получать "живой" эффект при использовании системы Surround sound (окружающий звук).

Можно выбирать один из двух режимов SPATIALIZER.

- Можно выбрать один из следующих режимов SPATIALIZER: LIVE, MONO или ВЫКЛ.

Более подробную информацию см. в разделе "Кнопка SPATIALIZER" на стр. 9.

Система SPATIALIZER изготовлена по лицензии компании Desper Products, Inc.

■ СУПЕР БАС

Для включения мощных басов можно использовать функцию Супер Бас.

ВКЛ :

Функция включается.

ВЫКЛ :

Функция выключается.

■ НАУШНИКИ

Эта функция дает возможность прослушивания звукового сопровождения через головные телефоны.

1 Выберите НАУШНИКИ и нажмите кнопку MENU/OK.

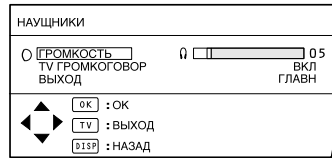

2 С помощью кнопки ▲/▼ сделайте выбор, а с помощью кнопки ◀/▶ установите функцию НАУШНИКИ. Нажмите кнопку ОК, а затем нажмите кнопку MENU/OK.

ГРОМКОСТЬ :

Имеется возможность регулирования громкости головных телефонов.

TV ГРОМКОГОВОР :

Когда эта функция включена, громкоговорители телевизора не выключаются даже при подсоединении головных телефонов. Если эта функция выключена, громкоговорители телевизора при подсоединении головных телефонов выключаются.

Если эта функция включена громкоговорители телевизора не выключаются даже при подсоединении головных телефонов.

Если выключить эту функцию, громкоговорители телевизора выключатся при подсоединении головных телефонов.

ВЫХОД :

При использовании головных телефонов можно выбрать источник звука как ОСНОВНОЕ изображение (ГЛАВН) или ДОПОЛНИТЕЛЬНОЕ изображение (ВТОРОСТЕП).

- Звуковое сопровождение ДОПОЛНИТЕЛЬНОГО изображения нельзя прослушивать через громкоговорители телевизора.
- При выводе на экран фрагмента изображения возможно только монофоническое звуковоспроизведение, использование функции СТЕРЕО/1•II будет невозможным.

Меню СВОЙСТВА

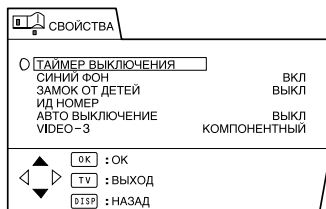

■ ТАЙМЕР ВЫКЛЮЧЕНИЯ

Можно задать автоматическое выключение телевизора в определенное время.

- 1 Выберите **ТАЙМЕР ВЫКЛЮЧЕНИЯ** и нажмите кнопку **MENU/OK**.

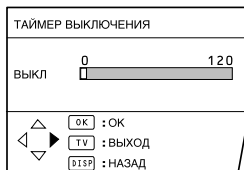

- 2 С помощью кнопок **◀/▶** установите период времени.

Таймер телевизора начнет отсчет заданного периода времени.

- Можно установить период времени длительностью до 120 минут (2 часа) приращениями по 10 минут.

Для отмены этой функции: нажмите кнопку **◀** для установки "ВЫКЛ".

- 3 Нажмите кнопку **MENU/OK** для завершения установки. Меню исчезнет.

- За одну минуту до выключения телевизора появится надпись "СПОКОЙНОЙ НОЧИ!".

- С помощью этой функции нельзя отключить сетевое питание телевизора.
- Когда эта функция включена, можно вызвать меню **ТАЙМЕР ВЫКЛЮЧЕНИЯ** для подтверждения или изменения оставшегося периода времени.

■ СИНИЙ ФОН

Имеется возможность автоматического изменения экрана телевизора на синий и выключения звука в случае слабого или полностью отсутствующего сигнала, или же в случае, если не поступает сигнал с внешнего устройства.

ВКЛ :

Функция включается.

ВЫКЛ :

Функция выключается.

■ ЗАМОК ОТ ДЕТЕЙ

Имеется возможность блокирования передних кнопок телевизора. Когда эта функция установлена на **ВКЛ**, телевизором можно управлять только с помощью пульта дистанционного управления. Используйте эту функцию для предотвращения управления телевизором детьми (без разрешения родителей).

ВКЛ :

Функция включается.

ВЫКЛ :

Функция выключается.

■ ИД НОМЕР

Если Вы не хотите, чтобы дети смотрели определенный телеканал, вы можете заблокировать этот телеканал. Если ребенок выберет номер программы, присвоенный заблокированному телеканалу, экран станет синим и на нем появится символ , так что изображение нельзя будет видеть.

Как включить эту функцию

- 1 Выберите ИД НОМЕР затем нажмите кнопку 0 (AV).



- 2 Установите ИД номер.

Для выбора номера:
нажимайте кнопки ▲/▼.

Для перемещения курсора:
нажимайте кнопки ◀/▶.

- 3 Нажмите кнопку MENU/OK.

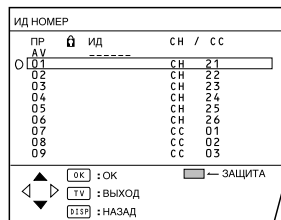

- 4 Нажимайте кнопки ▲/▼ для выбора телеканала.

- На экране появится программа, которая в настоящий момент транслируется по выбранному телеканалу.

- 5 Нажмите синюю кнопку для включения этой функции для данного телеканала.

Появится (ИД НОМЕР) и телеканал будет заблокирован.

Для отмены этой функции :

Снова нажмите синюю кнопку.

(ИД НОМЕР) исчезнет и телеканал будет разблокирован.

- 6 Нажмите кнопку MENU/OK для завершения установки.

Меню исчезнет.

Для просмотра заблокированного телеканала

- 1 Выберите номер программы с заблокированным телеканалом с помощью кнопок с цифрами или списка ПРОГ. ЛИСТ.

Экран станет синим и появится (ИД НОМЕР).

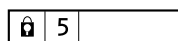

- Заблокированный телеканал нельзя выбрать с помощью кнопок ▲/▼.

- 2 Нажмите кнопку DISPLAY для вызова на экран “ИД НОМЕР”:

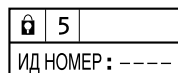

- 3 Введите ИД номер с помощью кнопок с цифрами.

Блокировка будет отменена, так что можно будет смотреть заблокированный телеканал.

Если Вы забыли ИД номер :

Выполните этап 1, чтобы “Как включить эту функцию”. После подтверждения ИД номера нажмите кнопку TV/VIDEO для выхода из меню.

- Для отмены функции ИД НОМЕР необходимо снова выполнить этап “Как включить эту функцию”.

■ АВТО ВЫКЛЮЧЕНИЕ

Имеется возможность автоматического выключения телевизора по завершении вещания, т.е. если он не принимает сигнала в течение около 15 минут.

ВКЛ :

Функция включается.

ВЫКЛ :

Функция выключается.

- Функция АВТО ВЫКЛЮЧЕНИЕ не обеспечивает отключения сетевого питания.
- Функция АВТО ВЫКЛЮЧЕНИЕ не работает в режиме ВИДЕО.

■ VIDEO-3

Эта функция обеспечивает правильную настройку VIDEO-3, соответствующую поступающему от внешнего устройства, через панель VIDEO-3, видеосигналу. При неправильной настройке изображения не будет.

ВИДЕО :

В случае, если поступает нормальный (полный) видеосигнал.

КОМПОНЕНТНЫЙ :

В случае, если поступает компонентный видеосигнал (Y/Cb/Cr).

- Подробную информацию по подсоединениям см. в разделе "ДОПОЛНИТЕЛЬНАЯ ПОДГОТОВКА" на стр. 36.
- Данный телевизор совместим с Progressive видеосигналом (сигналов 525P) только при подаче на вход компонентного видеосигнала.

Меню НАСТРОЙКИ

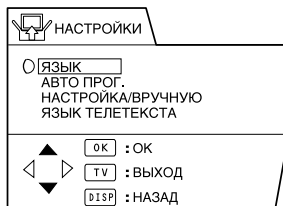

■ ЯЗЫК

Можно выбрать язык меню из списка языков.

- 1 Выберите **ЯЗЫК** и нажмите кнопку **MENU/OK**.

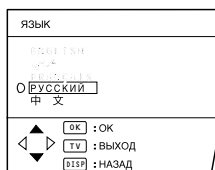

- 2 Нажимайте кнопки **▲/▼** для выбора языка.
- 3 Нажмите кнопку **MENU/OK** для завершения установки. Меню исчезнет.

■ АВТО ПРОГ.

Имеется возможность автоматической регистрации уверенно принимаемых телеканалов под номерами программ. Для этого выполните следующее.

- 1 Выберите **АВТО ПРОГ.** и нажмите кнопку **MENU/OK**.

Включится функция **АВТО ПРОГ.** Принимаемые телеканалы будут автоматически сохраняться в списке номеров программ.

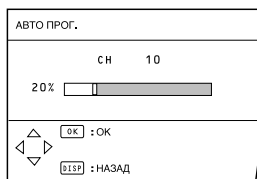

- Для отмены функции **АВТО ПРОГ.** нажмите кнопку **DISP**.

- 2 После сохранения телеканалов в списке номеров программ появится меню **НАСТРОЙКА**.

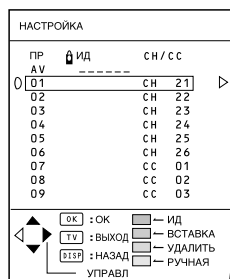

- После этого можно редактировать номера программ с помощью функции **НАСТРОЙКА/ВРУЧНУЮ**. Более подробную информацию см. в разделе "НАСТРОЙКА/ВРУЧНУЮ" на стр. 30.
- Если нужный телеканал не был сохранен в списке номеров программ, его можно зарегистрировать с помощью функции **РУЧНАЯ**. Более подробную информацию см. в разделе "НАСТРОЙКА/ВРУЧНУЮ" на стр. 30.
- Функция **АВТО ПРОГ.** не сохраняет телеканалы на программе с номером 0 (AV).
- Если функция **НАСТРОЙКА/ВРУЧНУЮ** не нужна, нажмите кнопку **MENU/OK** для выхода из меню **НАСТРОЙКА**.

■ НАСТРОЙКА/ ВРУЧНУЮ

Функции НАСТРОЙКА/ВРУЧНУЮ делятся на два типа:

редактирование текущих номеров программ (функция НАСТРОЙКА) и ручная регистрация телеканалов в список номеров программ (функция РУЧНАЯ).

ВНИМАНИЕ

- В результате использования функций УПРАВЛ, УДАЛИТЬ или ВСТАВКА происходит перезаписывание текущего списка номеров программ. В результате этого номера программ некоторых телеканалов изменятся.
- Если телеканал был заперт с помощью функции ИД НОМЕР использование функции РУЧНАЯ для этого телеканала приводит к отмене функции ИД НОМЕР.
- Если для номера программы PR 99 уже назначен телеканал, использование ВСТАВКА приведет к стиранию этого телеканала.

1 Выберите НАСТРОЙКА/ ВРУЧНУЮ и нажмите кнопку MENU/OK.

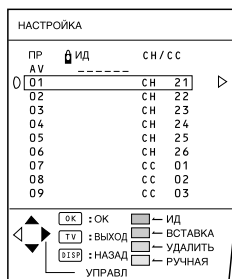

2 Используйте функцию согласно ее описанию.

УПРАВЛ :

Эта функция изменяет номер программы телеканала.

ИД :

Эта функция регистрирует название телеканала (ИД).

ВСТАВКА :

Эта функция добавляет новый телеканал к текущему списку номеров программ путем использования номера СН/СС.

УДАЛИТЬ :

Эта функция удаляет ненужный телеканал.

РУЧНАЯ :

Эта функция обеспечивает ручную регистрацию нового телеканала под номером программы.

3 Нажмите кнопку MENU/OK для завершения настройки.

- Для программы под номером PR 0 в списке номеров программ появляется "AV".

ФУНКЦИИ

УПРАВЛ

- 1 Нажимайте кнопки ▲/▼ для выбора телеканала.
- 2 Нажмите кнопку ► для включения функции УПРАВЛ.

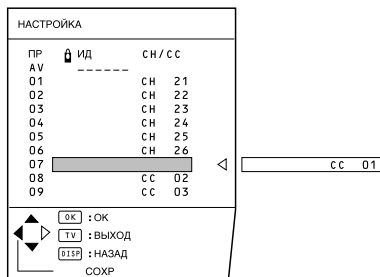

3 С помощью кнопок ▲/▼ выберите новый номер программы.

Для отмены функции УПРАВЛ :
нажмите кнопку DISPLAY.

- 4 Нажмите кнопку ◀ для изменения номера программы телеканала.

ИД

- 1 Нажимайте кнопки ▲/▼ для выбора телеканала.
- 2 Нажмите красную кнопку для включения функции ИД.
- 3 Введите название телеканала (ИД).

Пользуйтесь кнопками ▲/▼ для выбора знаков.

Пользуйтесь кнопками ◀/▶ для перемещения курсора.



Для отмены функции ИД:
нажмите кнопку DISPLAY.

- 4 Нажмите кнопку MENU/OK для регистрации названия телеканала.

УДАЛИТЬ

- 1 Нажимайте кнопки ▲/▼ для выбора телеканала.
- 2 Нажмите желтую кнопку для удаления телеканала.

Канал будет удален из списка номеров программ.

РУЧНАЯ

- 1 Нажимайте кнопки ▲/▼ для выбора номера программы, под которым Вы хотите зарегистрировать новый телеканал.
- 2 Нажмите синюю кнопку для включения функции РУЧНАЯ.

С правой стороны от номера СН/СС появится СИСТЕМА (системы звукового сопровождения) данного телеканала.

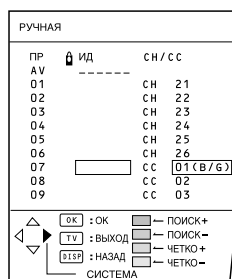

Для отмены функции РУЧНАЯ :
нажмите кнопку DISPLAY.

- 3 Нажимайте кнопку ▶ для выбора телевещательной системы (системы звукового сопровождения) для регистрируемого телеканала.
- Системы звукового сопровождения для различных регионов и стран приведены в таблице "ТЕЛЕВЕЩАТЕЛЬНЫЕ СИСТЕМЫ" на стр. 12.
- 4 Нажмите зеленую или красную кнопку для поиска телеканала.

Сканирование прекратится, когда телеканал будет найден. Этот телеканал появится на экране.

Как пользоваться меню телевизора

- 5 Нажимайте зеленую или красную кнопку до тех пор, пока не появится нужный телеканал.

При плохом приеме телеканала :
С помощью синей или желтой кнопки выполните тонкую настройку на этот телеканал.

Если не удается получить нормальное звуковое сопровождение даже при нормальном изображении :
Это указывает на неправильную настройку СИСТЕМА. Нажмите кнопку ► и выберите СИСТЕМА с нормальным звуковым сопровождением.

- 6 Нажмите кнопку MENU/OK для регистрации телеканала под номером программы.

Появится обычное меню НАСТРОЙКА.

- 3 С помощью кнопок ▲/▼ выберите “СН” или “СН” согласно номеру СН/СС телеканала.

Для отмены функции ВСТАВКА :
Нажмите кнопку DISPLAY.

- 4 С помощью кнопок с цифрами введите оставшийся номер СН/СС.

Телевизор переключится в режим регистрации. По завершении регистрации на экране телевизора появится изображение.

- Номер СН/СС указывает частоту, на которой ведется телевидение. Если телевизор не может обнаружить телеканал, соответствующий частоте телевидения, обозначенной номером СН/СС, появится заставка, указывающая на отсутствие сигнала.

ВСТАВКА

ПОДГОТОВКА

- Найдите номер СН/СС, соответствующий номеру телеканала, в табл. на стр. 33.

- 1 Нажимайте кнопки ▲/▼ для выбора номера программы, под которым регистрируется новый телеканал.
- 2 Нажмите зеленую кнопку для включения функции ВСТАВКА.

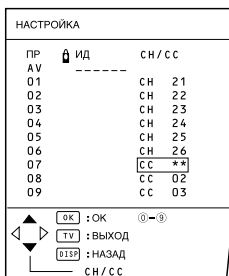

Номер CH/CC

Если требуется функция ВСТАВКА, описанная на стр. 32, найдите номер CH/CC, соответствующий телеканалу, по данной таблице.

US: Номера телеканалов, используемых в США, на Филиппинах и т.д.

CCIR: Номера телеканалов, используемых на Ближнем Востоке, в Юго-Восточной Азии и т.д.

OIRT: Номера телеканалов, используемых в Восточной Европе, России, Вьетнаме и т.д.

AUSTRALIA: Номера телеканалов, используемых в Австралии и т.д.

CH	US	CCIR	Канал OIRT	AUSTRALIA
CH 02	US-2	E2	R1	AU-0
CH 03	US-3	E3		AU-1
CH 04	US-4	E4	R2	AU-2
CH 05	US-5	E5	R6	AU-6
CH 06	US-6	E6	R7	AU-7
CH 07	US-7	E7	R8	AU-8
CH 08	US-8	E8	R9	AU-9
CH 09	US-9	E9		
CH 10	US-10	E10	R10	AU-10
CH 11	US-11	E11	R11	AU-11
CH 12	US-12	E12	R12	
CH 13	US-13			
CH 14	US-14			
CH 15	US-15			
CH 16	US-16			
CH 17	US-17			
CH 18	US-18			
CH 19	US-19			
CH 20	US-20			
CH 21	US-21	E21		
CH 22	US-22	E22		
CH 23	US-23	E23		
CH 24	US-24	E24		
CH 25	US-25	E25		
CH 26	US-26	E26		
CH 27	US-27	E27		
CH 28	US-28	E28		
CH 29	US-29	E29		
CH 30	US-30	E30		
CH 31	US-31	E31		
CH 32	US-32	E32		
CH 33	US-33	E33		
CH 34	US-34	E34		
CH 35	US-35	E35		
CH 36	US-36	E36		
CH 37	US-37	E37		
CH 38	US-38	E38		
CH 39	US-39	E39		
CH 40	US-40	E40		
CH 41	US-41	E41		
CH 42	US-42	E42		
CH 43	US-43	E43		
CH 44	US-44	E44		
CH 45	US-45	E45		
CH 46	US-46	E46		
CH 47	US-47	E47		
CH 48	US-48	E48		
CH 49	US-49	E49		
CH 50	US-50	E50		
CH 51	US-51	E51		
CH 52	US-52	E52		
CH 53	US-53	E53		
CH 54	US-54	E54		
CH 55	US-55	E55		
CH 56	US-56	E56		
CH 57	US-57	E57		
CH 58	US-58	E58		
CH 59	US-59	E59		
CH 60	US-60	E60		
CH 61	US-61	E61		
CH 62	US-62	E62		
CH 63	US-63	E63		
CH 64	US-64	E64		
CH 65	US-65	E65		
CH 66	US-66	E66		
CH 67	US-67	E67		
CH 68	US-68	E68		
CH 69	US-69	E69		
CH 70				

CC	US	CCIR	Канал OIRT	AUSTRALIA
CC 01		S-1		AU-5
CC 02		S-2		
CC 03		S-3		
CC 04		S-4		
CC 05		S-5		
CC 06		S-6		AU-5A
CC 07		S-7		
CC 08		S-8		
CC 09		S-9		
CC 10		S-10		
CC 11		S-11		
CC 12		S-12		
CC 13		S-13		
CC 14	A	S-14		
CC 15	B	S-15		
CC 16	C	S-16		
CC 17	D	S-17		
CC 18	E	S-18		
CC 19	F	S-19		
CC 20	G	S-20		
CC 21	H	S-21		
CC 22	I	S-22		
CC 23	J	S-23		
CC 24	K	S-24		
CC 25	L	S-25		
CC 26	M	S-26		
CC 27	N	S-27		
CC 28	O	S-28		
CC 29	P	S-29		
CC 30	Q	S-30		
CC 31	R	S-31		
CC 32	S	S-32		
CC 33	T	S-33		
CC 34	U	S-34		
CC 35	V	S-35		
CC 36	W	S-36		
CC 37	W+1	S-37		
CC 38	W+2	S-38		
CC 39	W+3	S-39		
CC 40	W+4	S-40		
CC 41	W+5	S-41		
CC 42	W+6			
CC 43	W+7			
CC 44	W+8			
CC 45	W+9			
CC 46	W+10			
CC 47	W+11			
CC 48	W+12			
CC 49	W+13			
CC 50	W+14			
CC 51	W+15			
CC 52	W+16			
CC 53	W+17			
CC 54	W+18			
CC 55	W+19			
CC 56	W+20			
CC 57	W+21			
CC 58	W+22			
CC 59	W+23			
CC 60	W+24			
CC 61	W+25			
CC 62	W+26			
CC 63	W+27			
CC 64	W+28			
CC 75		X		
CC 76		Y	R3	
CC 77		Z	R4	AU-3
CC 78		Z+1	R5	
CC 79		Z+2		AU-4
CC 95	A-5			
CC 96	A-4			
CC 97	A-3			
CC 98	A-2			
CC 99	A-1			

■ ЯЗЫК ТЕЛТЕКСТА

Имеется 4 группы языков телетекста. Выберите группу, которая соответствует языку программы телетекста, которую вы хотите смотреть.

1 Выберите ЯЗЫК ТЕЛТЕКСТА и нажмите кнопку MENU/OK.

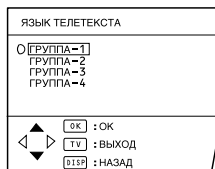

2 Нажмите кнопки ▲/▼ для выбора группы.

Группа	Языки
ГРУППА-1	Турецкий, венгерский, английский, немецкий, французский, итальянский, испанский, португальский, греческий, шведский, финский
ГРУППА-2	Польский, сербский, хорватский, словенский, чешский, словацкий, румынский, венгерский, немецкий, французский, итальянский, шведский, финский
ГРУППА-3	Русский, болгарский, латышский, литовский, эстонский, украинский, сербский, хорватский, словенский, чешский, словацкий, английский, немецкий
ГРУППА-4	Арабский, чешский, словацкий, венгерский, английский, немецкий, французский, итальянский, испанский, португальский, шведский, финский

3 Нажмите кнопку MENU/OK для завершения настройки.

Меню исчезнет.

- В случае выбора группы языков, в которой нет языка данной программы телетекста, этот телетекст не будет нормально отображаться.

Меню ДЕМО

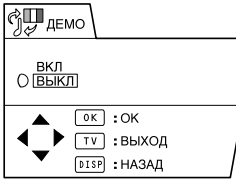

Функция ДЕМО обеспечивает автоматическую демонстрацию некоторых функций телевизора.

Когда функция ДЕМО установлена на ВКЛ :

при каждом включении телевизора начинается автоматическая демонстрация. Если демонстрация не требуется, установите функцию ДЕМО на ВЫКЛ.

1 Нажмите кнопку ▲/▼ для выбора ВКЛ.

Для отмены функции ДЕМО выберите ВЫКЛ.

2 Нажмите кнопку MENU/OK для завершения настройки.

Функция ДЕМО включается, в результате начнется демонстрация.

Для отмены демонстрации:

нажмите любую кнопку пульта дистанционного управления.

ДОПОЛНИТЕЛЬНАЯ ПОДГОТОВКА

■ Подсоединение внешних устройств

Подсоединяйте к телевизору внешние устройства с использованием следующей схемы подсоединения.

Перед выполнением любого подсоединения :

- Прочтите руководство к подсоединяемым устройствам. Способ подсоединения зависит от конкретных устройств и может быть отличным от способа, показанного на схеме. Кроме того, для обеспечения нормальной работы может потребоваться изменение настроек устройства в зависимости от способа соединения.
- Выключите все устройства, в том числе телевизор.
- В разделе "Технические данные" на стр. 43 содержится информация о панелях ВИДЕО. В случае подсоединения устройства, не включенного в приведенный ниже список, обратитесь к разделу "Технические данные" для выбора наиболее подходящей панели ВИДЕО.
- Имейте в виду, что соединительные кабели не входят в комплект поставки.
- При подсоединении устройств, поддерживающих AV COMPU LINK, обратитесь к разделу "Подсоединение устройств, поддерживающих AV COMPU LINK" на стр. 38.

- ① BM (полный сигнал)
- ② BM (сигнал S-VIDEO; Y/C)
- ③ BM для записи (полный сигнал)
- ④ DVD-плеер (полный сигнал)
- ⑤ DVD-плеер (сигнал S-VIDEO; Y/C)
- ⑥ DVD-плеер (компонентные видеосигналы; Y/Cb/Cr)
- ⑦ ТВ-игра (полный сигнал)
- ⑧ ТВ-игра (сигнал S-VIDEO; Y/C)
- ⑨ Видеокамера (полный сигнал)
- ⑩ Видеокамера (сигнал S-VIDEO; Y/C)
- ⑪ Головные телефоны

Ⓐ Кабель AV COMPU LINK

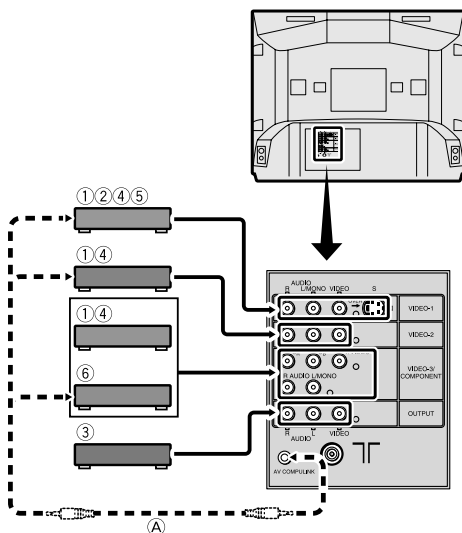
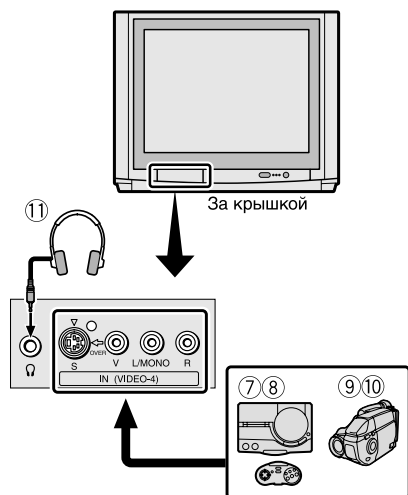

Способы подсоединения

- 1 Соедините гнездо VIDEO телевизора с гнездом VIDEO OUT (видеовыход) устройства с помощью видеокабеля.

Подсоединение устройства к телевизору с помощью кабеля S-VIDEO :

Соедините разъем S-VIDEO OUT (выход S-VIDEO) видеомагнитофона с разъемом "S" (S-VIDEO) телевизора с помощью кабеля S-VIDEO, а не видеокабеля.

Имейте в виду, что соединение с помощью видеокабеля не будет работать, если соединить VM с телевизором как с помощью видеокабеля, так и с помощью кабеля S-VIDEO.

Соединение DVD-плеера с телевизором с помощью компонентного видеокабеля :

Соедините три гнезда (Y/VIDEO, C_b и C_r) панели VIDEO-3 и COMPONENT (полный видеовыход) гнезда DVD-плеера с помощью компонентных видеокабелей, а не одного видеокабеля.

Затем установите VIDEO-3 на КОМПОНЕНТНЫЙ согласно разделу "VIDEO-3" на стр. 28.

- Данный телевизор совместим с Progressive видеосигналом (сигналом 525P). (если на вход подается совместимый видеосигнал). Если DVD-плеер подает Progressive видеосигналы (сигналы 525P) в качестве компонентных видеосигналов, соединение устройства с телевизором посредством компонентного видеокабеля позволит использовать запись на диски DVD в качестве исходного источника изображения.

Подсоединение устройства через панель VIDEO-3/COMPONENT с помощью видеокабеля :

Соедините гнездо Y/VIDEO телевизора и гнездо VIDEO OUT (видеовыход) с помощью видеокабелей, а не одного видеокабеля. Затем установите VIDEO-3 на VIDEO согласно разделу "VIDEO-3" на стр. 28.

- На панели VIDEO-4 гнездо VIDEO обозначено как "V".

- 2 Соединение аудиогнезд AUDIO (L/MONO и R) телевизора и гнезд AUDIO OUT (аудиовыход L/R) с помощью аудиокабелей.

Если звуковой сигнал устройства является монофоническим :

Соедините гнездо AUDIO OUT устройства с гнездом L/MONO телевизора с помощью аудиокабеля.

Подсоединение устройства к панели OUTPUT

Сигналы просматриваемых в данный момент изображений и звукового сопровождения выходят из телевизора через панель OUTPUT. Подсоединив VM к панели OUTPUT, можно записывать просматриваемые в данный момент изображение и звуковое сопровождение. Для этого достаточно подсоединить VM через панель OUTPUT согласно следующим инструкциям.

- 1 Соедините гнездо VIDEO панели OUTPUT с гнездом VIDEO IN (видеовход) видеомагнитофона при помощи видеокабеля.

ДОПОЛНИТЕЛЬНАЯ ПОДГОТОВКА

2 Соедините гнезда AUDIO (L и R) панели OUTPUT с гнездами AUDIO IN (аудиовход L/R) видеомагнитофона при помощи аудиокабеля.

- При выключении телевизора прекращаются сигналы через панель OUTPUT.
- Компонентные сигналы, поступающие через панель VIDEO-3/ COMPONENT, нельзя вывести через панель OUTPUT.

Подсоединение головных телефонов

Подсоедините головные телефоны со стереофоническим миништекером (диаметр 3,5 мм) к гнезду головных телефонов на передней панели телевизора.

■ Подсоединение устройств, поддерживающих AV COMPU LINK

Система дистанционного управления AV COMPU LINK обеспечивает автоматическое управление несколькими устройствами при выполнении управления только одним устройством.

Применительно к телевизору, в результате управления внешним устройством будет происходить автоматическое управление телевизором. Для включения телевизора или изменения режимов ВИДЕО не требуется использование пульта дистанционного управления.

Примеры работы системы дистанционного управления AV COMPU LINK

Нажимая кнопку PLAY видеомагнитофона или DVD-плеера, можно просматривать изображения на внешнем устройстве.

Если загрузить записанную пленку (на кассете с удаленным защитным язычком) в ВМ, можно смотреть запись.

Включать и выключать телевизор (находящийся в режиме ожидания) и переключать режимы ВИДЕО можно с помощью приемника управления AV.

- Работа системы дистанционного управления AV COMPU LINK зависит от подсоединенного устройства. См. руководства по устройствам.
- При выборе "ЗВУКОВОГО СОПРОВОЖДЕНИЯ ТВ" в качестве входного источника с помощью приемника управления AV может автоматически сработать функция ВЫКЛЮЧЕНИЕ ЗВУКА телевизора, так что звучание из громкоговорителей телевизора прекратится. В этом случае с помощью кнопок VOLUME-/+ или MUTEING пульта дистанционного управления отмените функцию ВЫКЛЮЧЕНИЕ ЗВУКА. В результате громкоговорители телевизора зазвучат снова.

Условия, при которых можно использовать систему дистанционного управления AV COMPU LINK

- Необходимо устройство, имеющее разъем AV COMPU LINK.

- Необходимо соединить телевизор и устройство с помощью кабеля AV COMPU LINK. Кабель AV COMPU LINK не входит в комплект поставки телевизора. Если кабеля AV COMPU LINK нет, соедините телевизор и устройство с помощью кабеля, на обоих концах которого имеются 3,5 мм (моно) штекеры.
- Устройство необходимо подсоединить к соответствующей панели ВИДЕО и правильно настроить, иначе система дистанционного управления AV COMPU LINK не будет нормально работать. Более подробную информацию см. в разделе "Настройка системы дистанционного управления AV COMPU LINK".
- Телевизор должен находиться в режиме ожидания (индикатор питания POWER должен гореть красным). Если телевизор отключен от источника питания (индикатор питания POWER телевизора не горит), система дистанционного управления AV COMPU LINK работать не будет.

Настройка системы дистанционного управления AV COMPU LINK

ВНИМАНИЕ :

- Способы настройки некоторых устройств отличаются от описанного ниже способа. Перед выполнением настройки обязательно прочтите руководство по устройству.

- 1 Подсоедините устройство к панели VIDEO-1 или VIDEO-2 телевизора.

При подсоединении DVD-плеера к телевизору с помощью компонентного видеокабеля :

Подсоедините DVD-плеер к панели VIDEO-3 телевизора.

- Подробные инструкции по подсоединению см. в разделе "Подсоединение внешних устройств" на стр. 36.

- 2 Соедините гнездо AV COMPU LINK телевизора с гнездом AV COMPU LINK устройства с помощью кабеля AV COMPU LINK.

- 3 Измените настройку устройства в соответствии с панелью VIDEO, с которой оно соединено.

Если BM соединен с панелью VIDEO-1 :

Установите код дистанционного управления видеомэгафона на А.

Если DVD-плеер соединен с панелью VIDEO-1 :

Установите режим AV COMPULINK DVD-плеера на DVD2.

Если BM соединен с панелью VIDEO-2 :

Установите код дистанционного управления видеомэгафона на В.

Если DVD-плеер соединен с панелью VIDEO-2 :

Установите режим AV COMPULINK DVD-плеера на DVD3.

Если DVD-плеер соединен с панелью VIDEO-3 с помощью компонентного видеокабеля :

Установите режим AV COMPULINK DVD-плеера на DVD1.

- Инструкции по изменению настроек устройств см. в руководствах по устройствам.
- Если подсоединяемое устройство не имеет ни кода дистанционного управления, ни режима AV COMPULINK, подсоедините его через панель VIDEO-1.

Устранение неисправностей

Если при пользовании телевизором возникает проблема, прочтите раздел "Устранение неисправностей" перед тем как обращаться к мастеру. Эта информация может помочь Вам в устранении проблемы без посторонней помощи. Если, например, вилка шнура питания выскочила из розетки или неисправна антенна, может возникнуть впечатление, что неисправен телевизор.

Внимание :

- В данном разделе рассматриваются только проблемы, источники которых неочевидны. Если у Вас возникнут вопросы по использованию каких-либо функций, прочтите сначала соответствующий раздел данного руководства, а не раздел "Устранение неисправностей".
- Если ни с помощью рекомендаций в разделе "Устранение неисправностей", ни с помощью описания соответствующей функции устранить проблему не удалось, выньте вилку шнура питания телевизора из розетки и обратитесь к мастеру. Не пытайтесь отремонтировать телевизор самостоятельно, не открывайте заднюю крышку телевизора.

■ Если телевизор не выключается

- Вставлена ли вилка шнура питания в розетку?
- Горит ли индикатор питания POWER? Если он не горит, нажмите кнопку выключателя питания.

■ Нет изображения/ Нет звука

- Не является ли сигнал выбранного телеканала слишком слабым? В этом случае сработает функция СИНИЙ ФОН - весь экран станет синим, звук прекратится. Если Вы все же хотите смотреть этот телеканал, прочтите описание функции "СИНИЙ ФОН" на стр. 26 и попытайтесь установить эту функцию на ВЫКЛ.
- Правильны ли настройки для СИСТЕМЫ ЗВУКА этого телеканала? Прочтите описание "Кнопка SOUND SYSTEM" на стр. 12 и попытайтесь устранить проблему.

■ Плохое качество изображения

- Если помехи полностью блокируют изображение (снег) причина может заключаться в неисправном кабеле или антенне. Проверьте следующее:

Правильно ли подсоединена антенна к телевизору?
Не поврежден ли кабель?
Правильно ли ориентирована антенна?
Исправна ли сама антенна?

- Если в телевизоре или антенне наводятся помехи от других устройств, на экране могут появиться полосы или другие помехи. Удалите такие помехогенерирующие устройства как усилители, компьютеры, фены, от телевизора или попробуйте установить телевизор в другом месте. Если в антенне наводятся помехи от радиомачты или высоковольтных линий, обратитесь к местному дилеру.
- Если телевизор принимает сигнал, отраженный от гор или зданий, изображение на экране будет двоиться. Попробуйте изменить ориентацию антенны или заменить ее новой, обладающей лучшей направленностью.

- Делайте ли вы постановку СИСТЕМА ЦВЕТНОСТИ для телеканала правильно? Для устранения этой проблемы используйте информацию в разделе "Кнопка COLOUR SYSTEM" на стр. 11.
- Правильно ли отрегулированы ЦВЕТ и ЯРКО? Для регулирования используйте информацию в разделе "Регулирование изображения" на стр. 20.
- Запись телетекста на ВМ не рекомендуется, т.к. он может записаться неправильно.
- Яркие белые изображения (например, белое платье) могут выглядеть на экране как цветные. Это неустранимое искажение, связанное с особенностями кинескопа, оно не является неисправностью. Неестественные цвета исчезнут при уходе с экрана яркого белого изображения.
- При просмотре изображений с помощью некоторых имеющихся в продаже пакетов программного обеспечения для видео или неправильно сделанных видеозаписей верхняя часть изображения может иметь искажения. Это связано с видеосигналом, а не с неисправностью телевизора.

■ Плохое качество звука

- Правильно ли отрегулированы БАС и ТЕМБР? Если нет, выполните регулировки, используя информацию в разделе "Регулировка звука" на стр. 24.
- При плохом приеме телеканала могут возникать трудности с прослушиванием стереофонического или двуязычного звукового сопровождения. В этом случае, используя информацию в разделе "СТЕРЕО / I • II" на стр. 24, переключитесь на монофоническое звуковое сопровождение.

■ Телевизор не работает

- Не пора ли заменить батарейки в пульте дистанционного управления? Установите новые батарейки согласно инструкциям в разделе "Установка батареек в пульт дистанционного управления" на стр. 4.
- Не пытаетесь ли Вы использовать пульт дистанционного управления, находящийся сзади или сбоку или на расстоянии более 7 м от телевизора? Расположите пульт дистанционного управления спереди от телевизора, на расстоянии не более 7 м от него.
- При просмотре телетекста пользоваться меню нельзя. Нажмите кнопку TV/VIDEO для переключения с телетекста на обычную программу и после этого попробуйте вызвать меню.
- Не включен ли ЗАМОК ОТ ДЕТЕЙ? Если функция ЗАМОК ОТ ДЕТЕЙ установлена на ВКЛ, пользоваться передними кнопками телевизора нельзя. Установите ЗАМОК ОТ ДЕТЕЙ на ВЫКЛ, используя информацию в разделе "ЗАМОК ОТ ДЕТЕЙ" на стр. 26.
- Если телевизор внезапно перестает работать, выключите питание кнопкой питания. Затем еще раз нажмите кнопку для включения питания. Если телевизор начинает после этого нормально работать, он исправен.
- При приеме Progressive видеосигналов (сигналов 525P) следующие функции не работают; Пульт дистанционного управления: ZOOM, PIP, MULTI, FREEZE и кнопка STROBE. Функции МЕНЮ: ЧЕТКО, ЦВ. ТОН, ЦИФРОВАЯ СПВШ, DigiPure и ZOOM.

■ Другие проблемы

- При включенной функции ТАЙМЕР ВЫКЛЮЧЕНИЯ или АВТО ВЫКЛЮЧЕНИЕ происходит автоматическое выключение телевизора. Если телевизор внезапно выключился, нажмите кнопку питания POWER для его включения. Если телевизор начинает нормально работать, он исправен.
- Если вы хотите, чтобы при подключении наушников звук из громкоговорителей ТВ не поступал, измените настройку TV ГРОМКОГОВОР. в меню НАУШНИКИ на ВЫКЛ. Подробные сведения см. под заголовком "НАУШНИКИ" на стр. 25.
- Если вблизи телевизора окажется магнитное устройство, такое как громкоговоритель, может произойти искажение изображения или в углах экрана может произойти искажение цветов. Удалите магнитное устройство от телевизора. Если помехи возникают от громкоговорителей, перейдите на использование экранированных громкоговорителей.
- Из-за влияния магнитного поля Земли может произойти перекося изображения. Для устранения перекося используйте информацию в разделе "PICTURE TILT" на стр. 23.
- При выполнении таких операций как переключение с телеканала на телеканал возникает кратковременный перерыв в передаче изображения. Это не является неисправностью. Этот перерыв необходим для стабилизации изображения.
- При резком изменении температуры телевизор может издавать потрескивание. Если изображение и звуковое сопровождение при этом нормальны, телевизор исправен. Если при работе телевизора потрескивание происходит часто, возможны другие причины этого явления - на всякий случай можно попросить мастера проверить телевизор.
- При прикосновении к экрану телевизора может ощущаться легкий электрический разряд статического электричества. Это неустраняемое явление, связанное с устройством кинескопа, оно не является неисправностью. Такой статический разряд не причиняет вреда организму человека.

Технические данные

Телевещательные системы:	B, G, I, D, K, K1, M
Системы цветности:	PAL, SECAM, NTSC3.58/4,43 MHz
Каналы и частоты	Канал низкой VHF (VI) = 46,25 - 168,25 Гц Канал высокой VHF (VH) = 175,25 - 463,25 Гц Канал UHF (U) = 471,25 - 863,25 Гц ■ Принимает кабельные телеканалы в среднем диапазоне (X - Z + 2, S1 - S10), супердиапазоне (S11 - S20) и гипердиапазоне (S21 - S41).
Системы мультиплексного звукового сопровождения	A2 (B/G), NICAM (B/G, I, D/K)
Системы телетекста	FLOF (Fastext), WST (World Standard Text)
Языки телетекста	См. таблицу в разделе "ЯЗЫК ТЕЛЕТЕКСТА" на стр. 34.
Питание	Пер. ток 110 - 240 В, 50/60 Гц
Аудиовыход	Номинальная выходная мощность: 20 Вт + 20 Вт
Панель VIDEO-1	Разъем RCA X 3, разъем S-VIDEO X 1 • Видеовход, вход S-VIDEO (Y/C) и аудиовходы L/R.
Панель VIDEO-2	Разъем RCA X 3 • Видеовход и аудиовходы L/R.
Панель VIDEO-3/COMPONENT	Разъем RCA X 5 • Видеовход/компонентный видеовход (Y/Cв/Cr) и L/R аудиовходы. • На вход подаются Progressive видеосигналы (сигналы 525P).
Панель VIDEO-4	Разъем RCA X 3, разъем S-VIDEO X 1 • Видеовход, вход S-VIDEO (Y/C) и L/R аудиовходы.
Панель OUTPUT	Разъем RCA X 3, • Видеовыход и аудиовыходы L/R.
Гнездо головных телефонов	Стерефоническое минигнездо (диаметр 3,5 мм)
Дополнительные устройства	Пульт дистанционного управления X 1 (RM-C214) Батарейки AA/R6 X 2
Громкоговорители	HV-34LPZ: 12 см, круглые, x2. 3.5 см, круглые, x2. HV-29LPZ: 10 см, круглые, x2. 3.5 см, круглые, x2.
Потребляемая мощность	HV-34LPZ: Максимальная 255 Вт, средняя 170 Вт HV-29LPZ: Максимальная 254 Вт, средняя 170 Вт
Размер кинескопа (по диагонали)	HV-34LPZ: Кинескоп 87см Размер изображения 80 см HV-29LPZ: Кинескоп 73см Размер изображения 68 см
Габариты (Д X В X Ш)	HV-34LPZ: 898 мм X 728 мм X 579 мм HV-29LPZ: 732 мм X 588 мм X 518 мм
Вес	HV-34LPZ: 75 кг HV-29LPZ: 48 кг

Конструкция и технические данные могут быть изменены без уведомления.

Изображения, получаемые на экране в результате использования функций ZOOM телевизора, запрещается использовать для каких-либо коммерческих или демонстрационных целей в общественных местах (кафе, гостиницах и т.п.) без получения предварительного согласия от владельцев авторских прав на исходный источник изображения.

JVC
VICTOR COMPANY OF JAPAN, LIMITED